



Allentown
FORMING TOMORROW'S CITY TODAY



Zoning Ordinance Update

Public Review Draft 2.0

February 7, 2025

How to Use the Zoning Ordinance

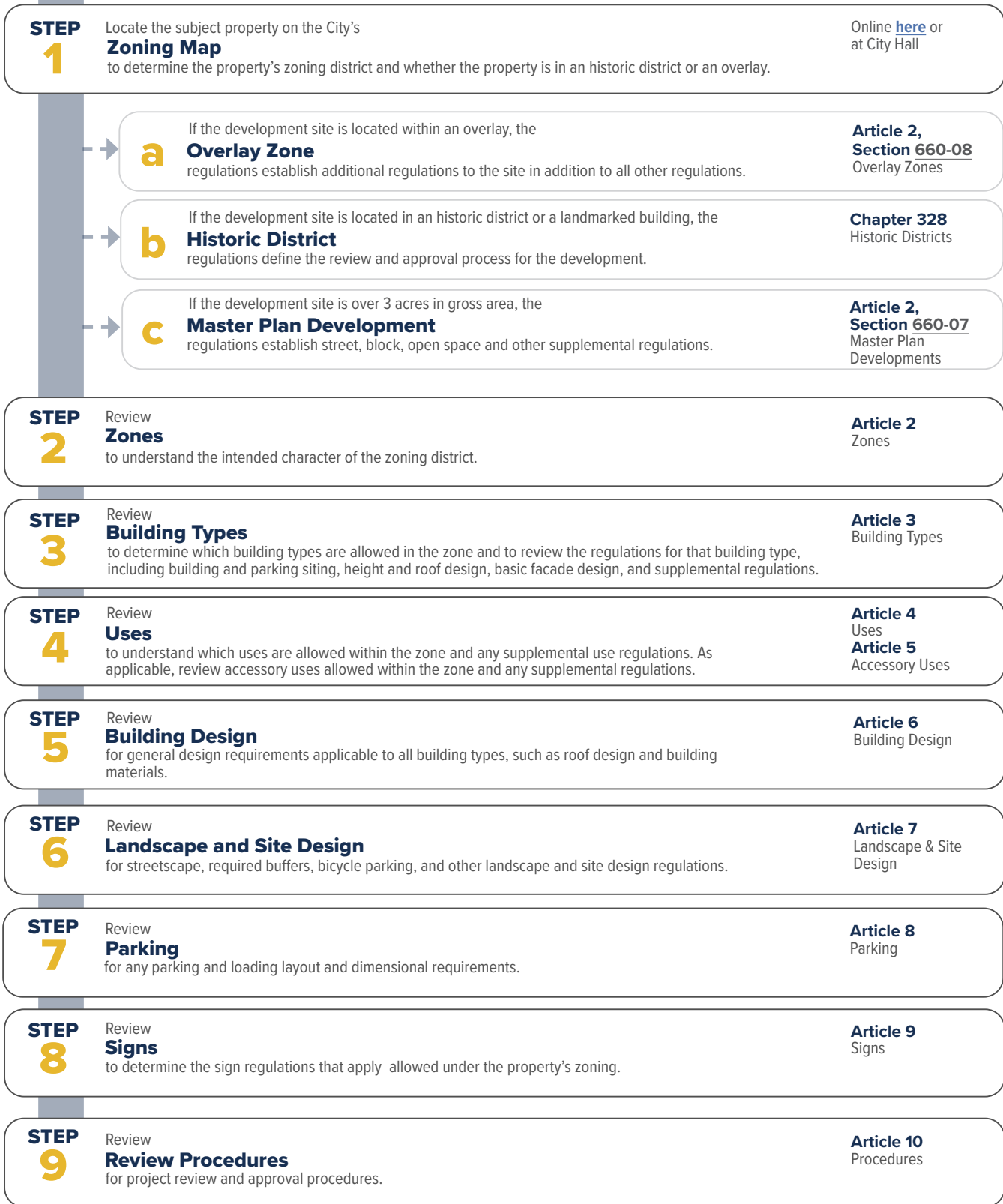

Contents

ARTICLE 1. INTRODUCTORY PROVISIONS..... 1-1
ARTICLE 2. ZONES..... 2-1
ARTICLE 3. BUILDING TYPES 3-1
ARTICLE 4. USES..... 4-1
ARTICLE 5. ACCESSORY STRUCTURES & USES 5-1
ARTICLE 6. BUILDING DESIGN 6-1
ARTICLE 7. SITE DESIGN 7-1
ARTICLE 8. PARKING, MOBILITY, & ACCESS 8-1
ARTICLE 9. SIGNS 9-1
ARTICLE 10. PROCEDURES10-1
ARTICLE 11. ADMINISTRATION..... 11-1
ARTICLE 12. NONCONFORMITIES12-1
ARTICLE 13. MEASUREMENTS & DEFINITIONS 13-1

[page intentionally blank]

DRAFT

ARTICLE 1. INTRODUCTORY PROVISIONS

660-01 Legal Framework 1-2
660-02 Zoning Map 1-3

660-01 Legal Framework

660-01.A TITLE

These regulations are officially known as "The Zoning Ordinance of the City of Allentown." For convenience the regulations are referred to throughout this document as the "zoning ordinance."

660-01.B AUTHORITY

This zoning ordinance is adopted pursuant to the city's home rule charter and the grant of powers contained in the Pennsylvania Municipalities Planning Code.

660-01.C EFFECTIVE DATE

The provisions of this zoning ordinance become effective on [effective date to be inserted], except as otherwise expressly stated herein.

660-01.D APPLICABILITY AND JURISDICTION

- (1) This zoning ordinance applies to all public and private use and development of properties within the corporate limits of the City of Allentown, except as otherwise provided by state or federal law or as otherwise expressly stated in this zoning ordinance.
- (2) This zoning ordinance does not apply to any lot, building, or use owned by the city or to any lot, building, or use authorized by the mayor or city council by virtue of a lease or other contract.

660-01.E PURPOSES

This zoning ordinance is adopted for the purposes of:

- (1) Protecting and promoting the public health, safety, and general welfare;
- (2) Implementing the policies and goals of the comprehensive plan, and other relevant, officially adopted plans of the city; and
- (3) Achieving all of the other stated purposes and objectives set forth in this zoning ordinance.

660-01.F COMMUNITY OBJECTIVES

This zoning ordinance is adopted to achieve the following community objectives:

- (1) To protect and preserve existing neighborhoods while encouraging reinvestment and revitalization;
- (2) To accommodate and promote walkable, mixed-use development patterns;
- (3) To increase opportunities for decent, safe, and affordable housing;
- (4) To protect historic resources;

¹ 20 days after passage of zoning ordinance by the city council and approval by the mayor.

- (5) To encourage use and expansion of alternative transportation modes, including transit, pedestrian and bicycle modes;
- (6) To preserve and promote employment-generating manufacturing uses;
- (7) To promote economic development; and
- (8) To implement other the policies and goals of the comprehensive plan.

660-01.G MINIMUM REQUIREMENTS

- (1) The regulations of this zoning ordinance are deemed the minimum requirements necessary to carry out their stated purpose.
- (2) In addition to the requirements of this zoning ordinance, all uses, buildings, structures, and signs must comply with all other applicable ordinances, laws, and regulations and with decisions made by other governmental or quasi-governmental bodies with jurisdiction.
- (3) All references in this zoning ordinance to other governmental regulations are for informational purposes only. Such references do not constitute a complete list of such regulations. These references do not imply any responsibility for the city to enforce regulations imposed by other authorities.

660-01.H COMPLIANCE REQUIRED

- (1) All lots created or modified must comply with all applicable provisions of this zoning ordinance.
- (2) Land may not be used for any purpose other than ones that are allowed by the provisions of this zoning ordinance.
- (3) A building or structure may not be erected, located, moved, reconstructed, extended, or structurally altered except as allowed by this zoning ordinance.
- (4) Buildings, structures, and land may be used and occupied only in compliance with the provisions of this zoning ordinance.

660-01.I CONFLICTING PROVISIONS

- (1) **State Law.** If the provisions of this zoning ordinance conflict with state law, state law prevails and governs.
- (2) **Other City Regulations.** If the provisions of this zoning ordinance are inconsistent with one another or if they conflict with provisions found in other adopted ordinances or regulations of the city, the more restrictive provision governs unless otherwise expressly stated. The more restrictive provision is the one that imposes more stringent controls.

(3) Private Agreements and Restrictions. The regulations of this zoning ordinance are not intended to abrogate or annul any easements, covenants, or other private agreements or restrictions.

(4) Text and Illustrations. In case of any difference of meaning or implication between the text of this zoning ordinance and any heading, drawing, table, figure or illustration, the text governs.

660-01.J DELEGATION OF AUTHORITY

Whenever a provision of this zoning ordinance requires the head of a department or another official or employee to perform an act or duty, that provision is to be construed as authorizing the department head or officer to delegate that responsibility to others over whom they have authority.

660-01.K EFFECT OF ORDINANCE AND APPROVALS

The provisions of this zoning ordinance or of any actions, permits, or decisions of the zoning officer or zoning hearing board are not to be interpreted as establishing an easement or authorization of an encroachment upon any property.

660-01.L SEVERABILITY

(1) If one or more provisions of this zoning ordinance, or the application of this zoning ordinance to specific properties is held by a court of competent jurisdiction to be unlawful, invalid, unenforceable, or preempted by applicable state or federal law or regulations, such provisions are deemed to be severed from this zoning ordinance. The city council declares that it would have passed the entire zoning ordinance, except those parts declared unlawful, invalid, unenforceable, or preempted, if it had knowledge that such parts would be declared unlawful, invalid, unenforceable, or preempted. All provisions not declared unlawful, invalid, unenforceable, or preempted therefore remain in full force and effect.

(2) If any requirement or condition attached to an approval given under this zoning ordinance is found to be invalid by a court of competent jurisdiction, it will be presumed that the approval would not have been given without the requirement or condition and, therefore, the subject approval will also be deemed invalid.

660-02 Zoning Map
.....

660-02.A ESTABLISHMENT

The location and boundaries of the zones defined in this zoning ordinance are shown on the city’s official zoning map, which are declared to be a part of this zoning ordinance.

660-02.B INTERPRETATION

If the street or lot layout actually on the ground, or as recorded, differs from the street or lot layout shown on the zoning map, the zoning officer is authorized to interpret the

map in a way that will best carry out the purposes and intent of this zoning ordinance for the subject area or zone.

660-02.C SPLIT-ZONED PARCELS

- (1)** The zoning map may not be amended to classify a single parcel into 2 or more base zones.
- (2)** No new parcel may be created, whether by division or combination of multiple parcels, that would result in a split-zoned parcel. Approval of a zoning map amendment (rezoning) classifying any proposed new parcel or parcels must be approved before the parcel is created.

660-02.D ZONING UPON ANNEXATION

When land is annexed or otherwise brought into the zoning jurisdiction of the city, it will automatically be classified in the N5 zone until such time that a zoning map amendment is approved assigning another zoning classification in accordance with the zoning map amendment procedures of 660-107.

[page intentionally blank]

DRAFT

ARTICLE 2. ZONES

660-03 Mixed-Use Zones 2-2
660-04 Neighborhood Zones 2-3
660-05 Industrial Zones 2-3
660-06 Public-Institutional Zones 2-3
660-07 Master Plan Developments (MPD) 2-3
660-08 Overlay Zones 2-4

660-03 Mixed-Use Zones

660-03.A ZONES ESTABLISHED

The city’s mixed-use zones are listed in Table 660-1. When this zoning ordinance refers to “mixed-use” zones, it is referring to these zones.

660-03.B ZONE DESCRIPTIONS

The following describes the general intent for each zone and how the zone is primarily intended to be used.

- (1) **MX-D, Mixed-Use Downtown Core.** The MX-D zone is primarily intended for the highest intensity of activity in the downtown, where mixed-use buildings include ground-floor storefronts and upper story offices, residential, and other commercial uses.
- (2) **MX-C, Mixed-Use Corridors.** The MX-C zone is primarily intended for the mixed-use corridors throughout the city, where walkable storefronts provide shopping and services for neighborhood residents with residential and office uses in upper stories.
- (3) **MX-S, Mixed-Use Suburban Centers.** The MX-S zone is primarily intended for mixed-use, regional-scale nodes within the city, where residents and visitors may access multiple uses by walking and automobile.
- (4) **MX-N, Mixed-Use Neighborhood Centers.** The MX-N zone is primarily intended for nodes at corners or along small-scale corridors where existing storefront buildings and converted residential buildings have served the neighborhoods with daily shopping and service needs.
- (5) **GX-D, Residential-Office Mix Downtown.** The GX-D zone is primarily intended for the areas surrounding the downtown core, where buildings may be single- or mixed-use with mainly offices, residences, and other supporting commercial uses.
- (6) **GX-C, Residential-Office Mix Corridor.** The GX-C zone is primarily intended for locations along corridors and in nodes, where residential and/or office buildings can mix comfortably with artisan production and limited commercial service uses. GX-C buildings may be larger and more intensive than GX-N buildings.
- (7) **GX-N, Residential-Office Mix Neighborhood Centers.** The GX-N zone is primarily intended for locations along corridors and in neighborhood nodes, where smaller-scaled buildings can house residential, office, artisan production, and limited commercial service uses.
- (8) **NX, Residential Mix Neighborhood.** The NX neighborhood zone is intended to allow a mix of residential buildings in a neighborhood development, typically with multiple buildings on a single lot.

Table 660-1. Zones

SYMBOL	ZONE NAME
MIXED-USE ZONES	
MX-D	Mixed-Use Downtown Core
MX-C	Mixed-Use Corridors
MX-S	Mixed-Use Suburban Centers
MX-N	Mixed-Use Neighborhood Centers
GX-D	Residential-Office Mix Downtown
GX-C	Residential-Office Mix Corridor
GX-N	Residential-Office Mix Neighborhood Centers
NX	Residential Mix Neighborhood
NEIGHBORHOOD ZONES	
N1	Urban Neighborhood
N2	Town Neighborhood
N3	Twinhouse-House Neighborhood 1
N4	Twinhouse-House Neighborhood 2
N5	House Neighborhood
INDUSTRIAL ZONES	
IX	Industrial-Commercial Mix
IG	Industrial General
IM	Industrial Manufacturing
PUBLIC-INSTITUTIONAL ZONES	
P1	Parks and Open Space
P2	Civic and Institutional Buildings and sites
OVERLAY ZONES	
SRO	Student Residence Overlay
SRRO	South Riverfront Redevelopment Overlay
HBDO	Historic Building Demolition Overlay
RRO	Riverfront Redevelopment Overlay
MUO	Mixed-Use Overlay

660-04 Neighborhood Zones

660-04.A ZONES ESTABLISHED

The city’s neighborhood zones are listed in Table 660-1. When this zoning ordinance refers to “neighborhood” zones or “N” zones, it is referring to the N1 through N5 zones.

660-04.B ZONE DESCRIPTIONS

The following describes the general intent for each zone and how the zone is primarily intended to be used.

- (1) **N1, Urban Neighborhood.** The N1 neighborhood zone is primarily intended to maintain and enhance the general physical form of the city’s oldest existing rowhouse neighborhoods.
- (2) **N2, Town Neighborhood.** The N2 zone is primarily intended to maintain and enhance the general physical form of the city’s existing, turn-of-the century rowhouse neighborhoods.
- (3) **N3, Twinhouse-House Neighborhood 1.** The N3 zone is primarily intended to maintain and enhance the physical form of neighborhoods of primarily twin-houses and houses on small-sized lots with a few small apartment buildings and some nodes of rowhouses.
- (4) **N4, Twinhouse-House Neighborhood 2.** The N4 zone is primarily intended to maintain and enhance the physical form of the existing neighborhoods with a mix of twin-houses and houses on small- and mid-sized lots.
- (5) **N5, House Neighborhood.** The N5 zone is primarily intended to maintain and enhance the physical form of neighborhoods with a wide range of house types on small-, mid-, and large-sized lots.

660-05 Industrial Zones

660-05.A ZONES ESTABLISHED

The city’s industrial zones are listed in Table 660-1. When this zoning ordinance refers to “industrial” zones or “I” zones, it is referring to these zones.

660-05.B ZONE DESCRIPTIONS

The following describes the general intent for each zone and how the zone is primarily intended to be used.

- (1) **IX, Industrial-Commercial.** The IX zone is primarily intended for vehicle-oriented commercial, low-impact manufacturing, and warehouse and wholesaling uses with more automobile and truck traffic than the MX zones. This zone is primarily intended for use outside of commercial corridors.
- (2) **IG, Industrial General.** The IG zone is intended to preserve locations for low- and moderate-impact manufacturing uses and industrial services.

- (3) **IM, Industrial Manufacturing.** The IM zone is primarily intended for a focus on and a wide range of manufacturing and associated industrial uses as well as industrial services.

660-06 Public-Institutional Zones

660-06.A ZONES ESTABLISHED

The city’s public-institutional zones are listed in Table 660-1. When this zoning ordinance refers to “public-institutional” zones or “P” zones, it is referring to these zones.

660-06.B ZONE DESCRIPTIONS

The following describes the general intent for each zone and how the zone is primarily intended to be used.

- (1) **P1, Parks and Open Space.** The P1 zone is primarily intended for open space, including permanent parks, recreation spaces, cemeteries, and water buffers.
- (2) **P2, Civic and Institutional Buildings and Sites.** The P2 zone is primarily intended for civic and institutional facilities, such as houses of worship, cultural or arts centers, city hall, hospitals, and community centers; and campuses, such as the historic fairgrounds, stadiums, and schools. This zone is also intended for public or private civic infrastructure, such as utility corridors or sites.

660-07 Master Plan Developments (MPD)

660-07.A APPLICABILITY

Proposed developments on a single lot or combination of lots totaling 5 acres or more of developable land must meet the Master Plan Development regulations of Article 3 of the land development and subdivision regulations, prior to any subdivision or submittal of a site plan for review.

- (1) Developable land includes any land that is not environmentally sensitive, including steep slopes or heavily wooded areas to be retained, as determined by the city engineer.
- (2) Developments on sites in I or P zones are exempt from master plan development requirements.

660-07.B BUILDING TYPES

Building types are allowed in accordance with regulations of the underlying zone. Building types other than those allowed in the underlying zone may be allowed subdivision of a lot for the building type and rezoning.

660-07.C USES

Uses are allowed in MPDs in accordance with the regulations of the underlying zone (see 660-28).

660-08 Overlay Zones

660-08.A GENERAL

As the name implies, overlay zones “over-ly” applicable base zone classifications to alter some or all of the base zoning regulations that apply to particular sites. Overlay zones work to modify or supplement the regulations imposed by the base zone when necessary to address special situations or accomplish specific city goals. Overlay zoning is primarily intended to be used when the base zone applied to an area remains generally appropriate, but when additional requirements would help implement the city’s planning goals or address an area-specific planning, design or land use regulation issue.

660-08.B INTERPRETATION

- (1) All applicable regulations of the underlying base zone apply to property in an overlay zone unless otherwise expressly stated in the overlay zone regulations.
- (2) When overlay zone regulations conflict with regulations that otherwise apply in the underlying base zone, the regulations of the applicable overlay govern. If a property is classified in multiple overlay zones and the regulations of one overlay zone conflict with the regulations of another overlay zone, the more restrictive regulations govern.

660-08.C ZONES ESTABLISHED

The city’s overlay zones are listed in Table 660-1. When this zoning ordinance refers to “overlay” zones, it is referring to these zones.

660-08.D SRO, STUDENT RESIDENCE OVERLAY

The Student Residence Overlay is established within the geographic overlay boundaries on the zoning map, to manage student residence uses per 660-30.B.

660-08.E SRRO, SOUTH RIVERFRONT REDEVELOPMENT OVERLAY

- (1) **Purpose.** The purpose of the South Riverfront Redevelopment Overlay (SRRO) is to allow for the development of mixed-use, walkable buildings and site design for GX-C-zoned properties within the geographic overlay boundaries depicted on the official zoning map.
- (2) **Applicability.** The SRRO is an optional district. Owners of GX-C-zoned properties within the boundaries of the SRRO have the option of developing property in accordance with the SRRO regulations of this section or in accordance with the regulations of the underlying (GX-C) zone. In order to use the SRRO regulations of this section, property owners must first secure approval of a master plan per Article 3 of the land use and subdivision regulations. Properties not zoned GX-C and properties not covered by an approved master plan may

not use the SRRO regulations of this section and are subject instead to compliance with the underlying zone regulations.

- (3) **Intent.** The regulations of the SRRO are primarily intended to serve the following purposes:
 - (a) To encourage new mixed-use development along the riverfront.
 - (b) To maintain access to the riverfront by the public.
 - (c) To create walkable blocks, extending the city’s gridded network of streets through the sites.
 - (d) To create a hierarchy of streets and alleys or service drives that prioritize continuous, pedestrian-oriented streetscape throughout the development.
- (4) **Building Requirements.** The building types of underlying zoning apply except as follows:
 - (a) **Storefront.** The Storefront Building type may be used in any underlying zone.
 - (b) **Setbacks.** No minimum building setbacks apply.
 - (c) **Building Coverage.** Maximum allowed building coverage is 90%.
 - (d) **Height.** No minimum or maximum height limits apply
- (5) **Allowed Uses.** The use regulations of the underlying zone apply in the SRRO, except that drug and alcohol rehabilitation facilities and halfway houses are expressly prohibited in the SRRO.
- (6) **Block Size.** Block length must be no more than 600 feet, with a maximum perimeter of 1800 feet, except that blocks longer than 600 feet may be approved if pedestrian access easements at least 20 feet in width with minimum 5-foot sidewalks, thereby effectively reducing the resulting pedestrian blocks to dimensions less than the block sizes defined above.
- (7) **Emergency Vehicle and Service Access.** The configuration of the lots and blocks must include alleys or service drives to accommodate parking and garage access, refuse and recycling pickup, emergency vehicles and utilities in the rear of lots.
- (8) **Riverside Drive Streetscape.** The minimum dimension required for streetscapes along ground stories is 20 feet (measured from edge of curb to front of building), with a clear sidewalk and street trees.
- (9) **Building Frontage.**
 - (a) **Building Frontage.** Must be designed to have a prominent frontage along Riverside Drive and the waterfront. Building entrances are encouraged a minimum of one per every 120 feet of front façade.

(b) **Commercial Frontage along Riverside Drive and the Waterfront.** Buildings must have an active ground floor commercial frontage along Riverside Drive and the waterfront.

(10) **Waterfront Buffer.** The minimum width for the waterfront buffer is 50 feet along all waterfronts. Dedicated waterfront access is required.

- (a) Within the waterfront buffer, a minimum 10-foot wide pedestrian and bicycle access path must be provided, extending along the waterfront.
- (b) A continuous publicly accessible 10 foot sidewalk or multi use trail must connect the waterfront to an existing street.
- (c) The developer shall work with the city to ensure adequate emergency vehicle access is available for properties included within the development as well as the adjacent waterway.
- (d) This provision may be modified for properties with less than 350 linear feet of waterfront.

(11) **Waterfront Views from Riverside Drive.** Properties situated between the waterfront and Riverside Drive must provide waterfront views from Riverside Drive. For every 500 linear feet of lot frontage along Riverside Drive -- one unobstructed open sightline, minimum 20 feet in width, must be provided through the lot towards the water from Riverside Drive.

- (a) An upland connection may be used to meet this requirement, provided the sightline is maintained from Riverside Drive to the waterway.
- (b) A publicly dedicated street abutting the property may also be used to meet this requirement, provided the sightline is maintained every 500 feet.

(12) **Vistas.** Views down streets that terminate at parcels (referred to as "vistas" in these regulations), including where a street might angle at less than 90 degrees, may be considered when laying out streets and blocks, and locating open space, parking, and buildings.

660-08.F HBDO, HISTORIC BUILDING DEMOLITION OVERLAY

(1) **Purpose.** The purpose of the regulations of the Historic Building Demolition Overlay (HBDO) is to manage the potential demolition of historic buildings within the city and to prevent the demolition of valuable historic assets that help define the distinctive architectural character, history, and sense of place of Allentown.

(2) **Intent.** The regulations of the HBDO are primarily intended to serve the following purposes:

- (a) To protect architectural resources, preserve local heritage, and retain existing, historically valuable buildings.
- (b) To establish a clear process to review the demolition of historic buildings.
- (c) To use, adapt, and rehabilitate existing buildings. To strengthen the local economy by promoting heritage tourism, improving property values and increasing investment in older buildings.
- (d) To carry out the recommendations of the comprehensive plan, including recommendations to preserve historic buildings and community character.

(3) **Authorization.** The regulations for this HBDO overlay are authorized by the following sections of the Pennsylvania Municipalities Planning Code, P.L. 805, No. 247 as re-enacted and amended:

- (a) Section 603(b)(2), which enables zoning ordinances to permit, prohibit, regulate, restrict and determine the size, height, bulk, location, erection, construction, repair, maintenance, alteration, razing, removal and use of structures;
- (b) Section 603(g)(2), which states that zoning ordinances must provide for the protection of natural and historic features and resources;
- (c) Section 604(f), which enables zoning ordinances to preserve the natural, scenic and historic values in the environment; and
- (d) Section 605(2)(i), which enables zoning ordinances to provide classifications within any zone for the regulation, restriction or prohibition of uses and structures at, along or near places having unique historical, architectural or patriotic interest or value.

(4) **Applicability.** This section applies to the demolition or partial demolition, as defined in 660-130, of any principal building or portion thereof within the HBDO that is visible from an A or B street and was constructed at least 50 years prior.

(a) The following are not required to be reviewed as part of the HBDO:

- [1] Any building, building element, or portion of a building added within the last 50 years, not deemed to be architecturally or historically significant. Significance is determined by the Planning Director or their designee.
- [2] A building that fronts on a C street.
- [3] Any building located within a historic district where demolition is regulated through the

Historic Districts ordinance (see Chapter 328 of the city code).

- [4] Accessory structures that are not attached to the principal building.
- [5] The removal of features that are not visible from an A or B street.
- [6] The removal of features that are only visible from a C street or alley.
- [7] Interior renovations that do not harm the structural stability of the building.

(5) Application and Approval Procedures. A building regulated by this section may not be demolished or partially demolished unless such action has been given special exception approval by the zoning hearing board in accordance with 660-110 and 660-08.F(9), and all requirements of the overlay have been met.

(6) Information Required. In addition to the required zoning permit application for the demolition, the following information must be submitted by the applicant:

- (a)** Recent and, if available, historic, exterior photographs of the building proposed for demolition. If the applicant is alleging that the building cannot be reused or rehabilitated, then interior photos and floor plans must be provided as needed to support the applicant's claim;
- (b)** A site plan drawn to scale showing existing buildings and the proposed demolition;
- (c)** A written statement of the reasons for the demolition; and
- (d)** A written statement of the proposed use of the site, and a proposed timeline for development of that proposed use.

(7) Self-Created Conditions. The conditions that justify the proposed demolition of a building regulated by this section may not have been self-created by the applicant. These conditions include, but are not limited to:

- (a)** Lack of proper maintenance of the building, including but not limited to structural elements, the roof, windows or architectural elements, or
- (b)** Leaving parts of a building open to the elements or accessible to vandalism.

(8) Evidence. The applicant must provide sufficient, credible evidence to justify any claims that a building cannot feasibly be repaired or reused per the city's Guidelines for Historic Districts, section 3.15 Demolition.

- (a)** Evidence may include such items as a professional conditions assessments, property appraisal, a written estimate of the costs of rehabilitation by

a qualified contractor, a written report from a professional engineer regarding the structural soundness of the building, and similar due diligence.

- (b)** The city may conduct an independent review to verify evidence submitted by the applicant.

(9) Special Exception Standards. For approval of a demolition, the standards of this section shall apply in place of any general special exception standards of this ordinance. In reviewing the application, the zoning hearing board must consider the following:

- (a)** The historical and architectural significance of the building proposed to be demolished and the effect of the proposed demolition on the historic character of the streetscape or surrounding neighborhood.
- (b)** The feasibility of other alternatives to demolition.
- (c)** Any potential community benefit that would accrue as a result of the demolition.
- (d)** In order to obtain approval for a proposed demolition, the applicant is required to provide credible evidence that proves to the satisfaction of the zoning hearing board that 2 or more of the following conditions exists:

- [1] The existing building cannot feasibly and reasonably be reused per the city's Guidelines for Historic Districts, section 3.15 Demolition, and that such situation is not the result of intentional neglect by the owner. Demolition is not appropriate if due diligence demonstrates that there is an economically viable use for the property.
- [2] The denial of the demolition would result in unreasonable economic hardship to the owner, and the hardship was not self-created. See 328-17 in the historic district ordinance for definition of unreasonable economic hardship.
- [3] The demolition is necessary to allow a project to occur that will have substantial public benefit or benefit to the surrounding neighborhood that would greatly outweigh the loss of any historic building. Public benefit must meet the vision, goals, and objectives in the Comprehensive Plan.
- [4] The building is not historically or architecturally significant.

(10) HARB Recommendation. The historical architectural review board (HARB) must provide a recommendation to the zoning hearing board concerning the historical

and architectural significance of the building proposed to be demolished and on the effect of the proposed demolition on the historic character of the streetscape or surrounding neighborhood. HARB must provide its recommendation within 30 days of receipt of the application prior to forwarding to the ZHB for the special exception process.

(11) Emergency Situations. The zoning officer may issue a permit for demolition of any portion of a building or a building deemed wholly unsafe without compliance with this section. Demolition must be limited only to any portion of the building deemed unsafe. The director of building standards and safety must certify in writing that the building or the portion of the building to be demolished represents a clear and immediate hazard to public safety, and that no other reasonable alternatives exist to demolition.

660-08.G RRO, RIVERFRONT REDEVELOPMENT OVERLAY

(1) Boundary. The Riverfront Redevelopment Overlay zone applies within the geographic overlay boundaries depicted on the official zoning map.

(2) Applicability and Phasing.

- (a)** The RRO district is an optional district that overlays the underlying zoning district. An applicant shall have the option of developing property under the RRO district or under the underlying district. Once a final plan is approved under the RRO district, it shall be completed under the RRO district provisions.
- (b)** Development in the RRO district shall first require approval as a planned residential development (PRD). The PRD approval process generally replaces the traditional land development and subdivision approval process. Once a PRD has been granted final approval by the city planning commission, then individual uses allowed in the RRO district shall be permitted by right, provided they are consistent with the approved PRD plan. If uses or development are proposed that are inconsistent with the approved PRD plan, then the PRD plan revisions shall first be approved by the planning commission.
- (c)** The provisions of this RRO district shall only be available to be utilized if the total area of the tract is greater than 20 acres in common ownership or common equitable ownership at the time of tentative PRD plan submission. Each phase of development shall include a minimum of three acres. For the purposes of the RRO district, a tract may include lots that are separated from each other by a street, a railroad, an alley, a vehicle

accessway, or a similar land area intended for vehicle access. Once one PRD has been approved in the RRO district, then a second contiguous PRD in the RRO district shall have a minimum tract size of three acres, provided that the second PRD is coordinated in uses and traffic access with the first PRD. The intent is to have the second PRD serve as an extension of the first PRD, even though the developer and ownership may be different.

(3) Use Regulations

(a) Permitted Uses. The following uses are permitted by-right in the RRO district, provided approval is first granted as a PRD:

- [1] Twin dwelling or two-family dwellings.
- [2] One or more apartment/multifamily dwellings within a building that includes a principal nonresidential use.
- [3] Multifamily dwellings (other than conversions), three or more dwelling units on a lot.
- [4] Rowhouse/townhouse.
- [5] Residential conversion of an existing building to result in an increased number of dwelling units, other than above.
- [6] Amusement arcade.
- [7] Bed-and-breakfast inn.
- [8] Business services.
- [9] Catering, preparation of food for (this use may be combined with a restaurant if the requirements for a restaurant are also met).
- [10] Commercial communications tower/antenna, non-freestanding extending less than 25 feet above an existing principal building, structure, or public utility transmission tower that is over 60 feet in height.
- [11] Custom crafts, manufacture and sale of (such as jewelry and handicrafts), or artisan's studio retail craft shops such as, but not limited to, artisan shops, glass blower shops, ceramic tile maker shops.
- [12] Exercise club, or fitness facility, including indoor or outdoor swimming pool.
- [13] Financial institution (which includes a bank but which does not include a check cashing establishment or pawn shop, each of which shall be considered a retail store).
- [14] Hotel or motel, which may include a restaurant and conference center.

- [15] Massage establishment meeting the city massage establishment ordinance.2 All other massage establishments shall be prohibited.
- [16] Offices of business, institution, profession, medical, or similar entity (see also home occupation).
- [17] Personal services (such as barbershops, beauty shops, laundry and dry cleaning pickup and delivery, and closely similar uses).
- [18] Printing and duplication, custom (see also printing as an industrial use).
- [19] Recreation, commercial, indoor or outdoor, other than an adult use or amusement arcade.
- [20] Restaurant, includes takeout, without drive-through service.
- [21] Restaurant, includes takeout, with drive-through service.
- [22] Retail store (such as a drug store or variety store, other than adult use).
- [23] Shopping center.
- [24] Tavern or nightclub, which may include a brewpub that manufactures alcoholic beverages for on-site and off-site sale.
- [25] Theater (not including an adult use), civic and/or cultural facility, arena, gymnasium, auditorium or sports stadium.
- [26] Trade school or similar educational institution.
- [27] Veterinarian, other than kennel.
- [28] Research and development, engineering or testing facility or laboratory.
- [29] Adult day-care center.
- [30] Child-care center, nursery school, preschool or "head start" program center.
- [31] College or university.
- [32] Museum or visitor's center, and which include accessory retail sales.
- [33] Nursing home or personal care home.
- [34] Community center, nonprofit.
- [35] Government uses (not including prisons, other correctional facilities and solid waste facilities).
- [36] Membership club.
- [37] Public park, playground or other publicly owned recreation facilities or noncommercial outdoor recreation areas.
- [38] Boat dock, wharf or marina.
- [39] Swimming pools, household or non-household, public or private.
- [40] Bus and taxi shelters.
- [41] Telephones, pay or vending machines, outdoors.
- [42] Parking, off-street, public or private, surface or structured, as a principal or accessory use of lot.
- [43] Public utility; other facilities such as electric substations, but not including vehicle garages, warehouses, storage yards or commercial communications antennas.
- [44] Accessory use and/or structure on the same lot and customarily incidental to a lawful principal use.
- [45] Community events and displays.
- [46] Family child-care home.
- [47] Group child-care home.
- [48] Home occupation, medical, dental, chiropractic or similar licensed and professionally certified doctor, which shall be limited to one such doctor per dwelling.
- [49] Home occupation, all types.
- [50] Manufacturing as a routine and customary accessory use to the permitted principal use of the lot (see also "custom crafts").
- [51] Warehousing as an accessory use to the permitted principal use of the lot.
- [52] Community center.
- [53] Public park on public recreation facilities or noncommercial outdoor recreation areas.
- [54] Schools, public and private.
- [55] Wholesale, provided that the planning commission finds that:
 - [i] Such use (including any accessory warehouse use) occupies no more than 10% of the aggregate floor area shown on the PRD plan;
 - [ii] The type and scale of the wholesale use is compatible with the overall intent and mix of uses proposed for the PRD;
 - [iii] The use's location, proposed access, loading and unloading facilities and exterior are designed such that the proposed use does not substantially detract from

the architectural design, functionality and overall design of the remainder of the PRD.

(b) Prohibited Uses. Drug and alcohol rehabilitation facilities and halfway houses are expressly prohibited in the RRO district.

(4) Area, Yard and Building Regulations.

- (a)** The following area, yard and building regulations shall apply for all uses other than industrial uses, whichever is most restrictive; however they shall not apply to a change of use of a building that existed on the tract prior to the enactment of this RRO district.
- (b)** Maximum residential density: 25 dwelling units/acre. (Note: The maximum residential density shall be based upon the total area of the tract, before the deletion of rights-of-way of proposed streets and before the deletion of open space. Dwelling units may be located within the same building as allowed nonresidential uses, provided such mixture of uses is consistent with the approved Master Plan.)
- (c)** Minimum lot area: none.
- (d)** Minimum lot width: 20 feet. (Note: Individual uses or buildings may be owned in a condominium arrangement, without each condominium unit needing to meet the minimum dimensional requirements (such as lot width and yards), provided that the applicant shows that the development would have been able to meet the dimensional requirements if individual lot lines had been established.)
- (e)** Minimum building setback from the perimeter of the tract: 20 feet, except a minimum of 50 feet from a residential district boundary for a building of greater than 40 feet in height.
- (f)** Minimum front yard setback: zero feet.
- (g)** Minimum rear yard setback: zero feet.
- (h)** Minimum side yard setback: zero feet.
- (i)** Maximum building coverage: 70%. (Note: The maximum building coverage shall be based upon the ground level footprint of all buildings on the tract divided by the total area of the tract. Individual lots may have a higher building coverage, provided that the maximum is not exceeded for the tract. The city may require that certain lots include a deed restriction limiting their maximum coverage to ensure that the maximum overall coverage requirement is met across the tract over time.)
- (j)** Maximum building height: 140 feet.

- (k)** Buffer yard required: No, except a ten-foot-wide buffer yard shall be required if a preexisting principal dwelling in a residential district is adjacent or across a street or alley from a new principal business use and such dwelling is not within the RRO district.
- (l)** Site plan review by city: yes.
- (m)** Riverfront building setback: minimum of 25 feet from the top of the bank of the Lehigh River or a structural wall along the Lehigh River, based upon conditions that will exist after the development is completed, based upon the approved final PRD plan.
- (n)** Each single-family detached, twin and townhouse dwelling shall have a private outdoor area including a minimum area of 400 square feet for the exclusive use of that dwelling unit. Such outdoor area may be a rear or side yard, a porch, a balcony, a deck, an improved rooftop recreation area with railings, or a similar feature.

(5) Uses Allowed in Underlying District. For a use allowed by the underlying zoning district (such as a manufacturing use) that is not allowed in the RRO district regulations, all of the regulations of the underlying zoning district shall apply instead of the regulations of the RRO district. Once a final PRD plan has been approved for a phase, then within the land area of that phase, only uses that are allowed in the RRO district shall be allowed, provided that other lawful preexisting uses may be continued as nonconforming uses.

(6) Minimum Business Uses. A minimum of 20% of the total floor area of all enclosed buildings after completion of the development of the tract shall be occupied by business uses. Areas used for vehicle parking shall not be considered in this calculation.

(7) Open Land. A minimum of 10% of the total lot area of the tract shall be set aside in open land that is available for active and passive outdoor recreational use by the residents and employees of the tract, or by the general public. Such open land shall be maintained in existing trees or may be planted with new trees and shrubs or improved for outdoor recreational facilities. Such open land shall be regulated by a conservation easement or deed restriction established by the applicant and enforceable by the city of Allentown, which prohibits the construction of buildings and the further subdivision of the required open land.

(a) Outdoor recreational facilities shall be landscaped and may include sidewalks, pathways, and structures typically included in active and passive recreational areas. Areas used for buildings or

vehicle parking shall not count towards the open land requirement, except areas for rooftop active recreation facilities that are available to all residents of the tract may count as open land areas.

- (b) Unless dedicated to and accepted by the city of Allentown as part of a final PRD plan, such open land shall be owned and maintained by a legally binding association of property owners on the tract. The form of the property owners' legal documents shall be subject to review by the city solicitor. If there is mutual written agreement between the applicant and the city, part or all of the open land may be maintained as a public park.
 - (c) The open land shall be focused on taking advantage of the riverfront by providing for substantial public access along the banks of the river. Some of the open land may also serve the purpose of buffering residences from high-traffic roads.
- (8) Riverfront Access.** The RRO district offers great flexibility to the developer as an optional form of development. In return for such flexibility, a developer shall only be eligible to use this RRO district if the developer commits to providing public access to and along the Lehigh Riverfront. The tract shall be designed to provide continuous public pedestrian and bicycle access from sunrise to sundown, at a minimum, from public streets to the riverfront, and then along the length of the riverfront along the entire tract. Such public access shall be provided upon completion of each phase for land in that phase adjacent to the riverfront. Complete public access along the entire riverfront shall be provided upon completion of the development, including provisions for future extension of public pathways from the edges of the tract. The planning commission may approve alternative access through the tract if public access at a particular part of the riverfront is not feasible. Such public access shall include a pedestrian pathway with a minimum hard-surfaced width of 12 feet and a public pedestrian access easement with a minimum width of 14 feet. Such pathway may also be open to maintenance vehicles and bicycles. Such pathway may be gated and closed to the public between sunset and sunrise. Such riverfront pathway shall be illuminated and landscaped and shall connect with any existing or planned public trail adjacent to the tract.
- (9) Fire Access.** The applicant shall prove to the satisfaction of the planning commission, after a review by the fire department, that all buildings will be adequately accessible by fire apparatus, and that there will be at least two entrances into the development for fire

trucks. The city may require that buildings be sufficiently separated to allow firefighting access. Where streets do not provide adequate access to various sides of a building, the city may require that a pedestrian pathway be constructed with sufficient paving depth and width so that the pathway will be suitable for use by fire trucks. Where there is no need for a pathway, the city may require other provisions for fire truck access, such as a stabilized surface under grass.

- (10) Site and Building Layouts.** The following provisions shall be applied to the tract to the satisfaction of the planning commission:
- (a) The tract shall include at least one pedestrian-oriented main street, with pedestrian entrances and pedestrian amenities along that street and with no off-street parking spaces located between such main street and the front of abutting principal buildings, except for loading/unloading spaces. Commercial establishments shall be placed along at least a portion of the street level building space along a pedestrian-oriented main street.
 - (b) Along this pedestrian-oriented main street, a minimum of 50% of the front wall of each principal building shall not have a setback of greater than 20 feet from the curblin. The planning commission may approve a wider setback where appropriate to provide room for pedestrian amenities or an outdoor cafe. This maximum requirement shall not apply along a cul-de-sac extension of a main street.
 - (c) Garbage collection, business truck unloading areas and similar building services shall be situated so as to be accessed from a secondary street or alley and generally be shielded from pedestrian view along the fronts of new principal buildings.
 - (d) A minimum of two streets shall enter the tract after completion. At least one street shall extend through the bulk of the interior of the tract. The use of a grid-like street system divided into blocks shall be provided in the majority of the tract. The tract shall have a central focal point, such as a landscaped central green space and at least one main-street-style area with commercial uses.
- (11) Approval Process.** Development under the RRO district shall require approval by the planning commission as a planned residential development (PRD). The requirements and procedures for a PRD of the State Municipalities Planning Code are hereby included by reference.
- (a) A tentative plan submittal shall be made that includes the entire tract. The tentative plan submittal shall meet all of the requirements

that would apply to a preliminary plan under Chapter 350, Land Development and Subdivision Regulations, except that the following submission requirements shall be deferred from the tentative plan to the final plan stage, provided the applicant shows the general feasibility of such features:

- [1] Stormwater calculations.
- [2] Housing numbering plans.
- [3] Proposed monuments.
- [4] Exact locations and species of plantings for landscaping plans.
- [5] Elevations of proposed sanitary sewage lines and storm drains.
- [6] Designs of culverts, manholes, catch basins and similar construction details.
- [7] Locations of proposed electric, telephone and cable television lines and water and sewage laterals.

(b) After a Tentative plan has been approved, a final plan shall be submitted, which may occur in logical self-sufficient phases. The final plan shall meet all of the same requirements that would apply to a final plan under Chapter 350, Land Development and Subdivision Regulations. The final plan shall need approval by the planning commission.

- [1] No sale of lots or construction of buildings shall occur until after an approved final PRD plan has been approved by the planning commission and has been recorded, after the applicant has proven they have met any conditions upon approval and after acceptable financial guarantees for improvements have been established.

(c) A PRD shall meet all of the requirements of this chapter and Chapter 350, Land Development and Subdivision Regulations, that are not specifically modified by this section or by the provisions of the State Municipalities Planning Code that governs PRDs.

(12) Master Plan. Prior to the development of any new building under these RRO district provisions, the applicant shall submit an overall master plan ("master plan") for the tract. The master plan shall be submitted to the planning director and be reviewed by the planning commission and the city engineer. The plan shall also be submitted to appropriate agencies for review and comment. Within a maximum of 90 calendar days after the receipt of a complete zoning application and master plan, the planning commission shall vote to accept the

master plan or to identify items that need to be revised, unless a written extension is granted by the applicant.

- (a)** The master plan may include a range of allowed uses in various areas, as opposed to identifying each specific use. The overall master plan shall show the preliminary layout of proposed streets, alleys, cartway widths, lots, public trails, recreation areas, major pedestrian and bicycle pathways, heights and uses of buildings, parking areas, major detention basins, and proposed types of housing and nonresidential uses.
- (b)** The master plan is intended to show the interrelationships and compatibility of various elements of the PRD. The master plan shall be to scale and be designed to show how the PRD will comply with this zoning ordinance.
- (c)** The master plan may be combined with the PRD tentative plan if the requirements for such a plan are met, or may be submitted prior to the tentative plan. The master plan is not required to include engineering details that are required under Chapter 350, Land Development and Subdivision Regulations, provided that such information is submitted as part of the final PRD plan in the future.
- (d)** The applicant shall also submit a completed zoning permit application with the master plan. Approval of the zoning permit application shall be conditioned upon approval of the final PRD plan.

(13) Phasing. As each phase of development is approved, the applicant shall provide evidence that the requirements of this RRO district will be met, even if later phases of development would not be completed. This shall include, but not be limited to, providing evidence of compliance with the density, bulk, and open land requirements. Each phase of development shall be developed in full coordination with prior and future phases, to ensure that proper traffic circulation and utility services will be provided, and to ensure general compliance with the master plan.

- (a)** If one phase includes dwellings, then the planning commission shall have authority to require provisions for transitional buffering and setbacks between those dwellings and any adjacent industrially zoned land. Such buffering and setbacks are intended to make sure that there will be a compatible border between dwellings and industrial uses, in case later phases are not developed.

- [1] The planning commission may require that financial guarantees be provided by the

developer to fund buffer plantings if adjacent phases are not built.

- [2] The planning commission may require that a building setback be provided for dwellings from the edge of a future phase.
- [3] If such future adjacent phase is completed in conformance with the master plan, then such buffer and setback requirement is eliminated.

- (b) If a particular final plan is not generally consistent with the approved tentative plan, then the applicant shall submit a revised tentative plan for acceptance by the planning commission. However, the approved tentative plan is not required to be revised for matters addressed in the final plan that do not affect zoning ordinance compliance, such as adjustments in street alignments or changes in building shapes to reflect more detailed design.

(14) Architecture. To carry out the intent of traditional neighborhood development, prior to receiving tentative PRD approval, the applicant shall submit a set of preliminary architectural sketches and the substance of draft architectural covenants to the planning director, the city solicitor's office and the planning commission for review and comment. Such provisions shall be prepared with the involvement of a registered architect. The applicant shall establish a set of architectural covenants as a condition of final plan approval, prior to the recording of such plan. The applicant shall also establish a set of covenants to regulate the design of signs that are visible from the riverfront. Architectural covenants recorded for the site shall supersede any applicable building design standards in Article 6.

(15) Covenants. The city may also require covenants or conditions upon the plan to address setbacks, landscaping, pedestrian access, fire access, and other matters necessary to carry out the intent of this overlay district.

(16) Public Access. The master plan, tentative plan and final plan shall each describe the locations and extent of public access to the Lehigh Riverfront.

(17) Traffic Study and Improvements. As part of the tentative plan submittal, the applicant shall submit a traffic impact study to the city. Such study shall assess current traffic conditions, the amount of traffic expected to be generated by the total development, the impacts upon traffic, and measures that the applicant proposes to complete or fund to mitigate the impacts. Such traffic impact study shall be updated as needed as each phase is submitted. If diagonal parking is proposed along a street, the traffic impact study shall assess the safety of such parking in that location.

- (a) The applicant shall prove that the level of service of traffic will not be reduced below a level of D for adjacent public street intersections as a direct result of the new development. This level of service analysis shall consider traffic improvements that the applicant commits to fund as well as projects that are officially programmed for funding by the state.

[1] This subsection G(6)(a) may be modified by the planning commission if the applicant proves that a reduction in level of service is unavoidable because the applicant, the state and the city do not control sufficient right-of-way to make the needed traffic improvement.

[2] Prior to granting a modification of this Subsection G(6)(a), the planning commission shall determine that the evidence has been provided to them to show that the level of service will not result in congestion that would be a threat to public health and safety.

(18) Street and Alley Requirements. As authorized under the TND and PRD provisions of the State Municipalities Planning Code, the following alternative is specifically allowed under the requirements of Chapter 350, Land Development and Subdivision Regulations, for development within the RRO district:

- (a) The following street right-of-way and cartway widths shall be allowed for new streets that are not dedicated to the city or the state, in addition to options that are allowed under Chapter 350, Land Development and Subdivision Regulations:

[1] A collector street with two-way traffic may be constructed with two travel lanes of 11 feet each, diagonal parking lanes of 18 feet each or eight feet wide parallel parking lanes, a four-foot-wide planting strip with street trees on each side of the street (which may utilize tree wells), pedestrian sidewalks on each side of the street that are a minimum of five feet in width, and a right-of-way width that extends a minimum of nine feet on either side of the curbline.

[2] A local street with two-way traffic may be constructed with two travel lanes of 10 feet each, eight feet wide parallel parking, a 4.5-foot-wide planting strip (which may utilize tree wells) with street trees on each side of the street, pedestrian sidewalks on each side of the street that are a minimum of 4.5 feet and a minimum right-of-way width that extends a minimum of nine feet on either side of the curbline.

- [3] An alley serving two-way traffic may be constructed with a 16 feet wide cartway and an eight feet minimum setback between the travel lane and any rear garage.
- [4] The planning commission may require wider cartway widths as needed, considering the results of the traffic impact study.

(b) Any street within the RRO district, whether public or private, shall meet the same minimum construction material requirements as any new street intended to be dedicated to the city under city ordinances, or as otherwise approved by the city.

- [1] Pedestrian sidewalks with a minimum width of 4.5 feet and street trees meeting requirements of the city shall be required on each side of every street. A minimum average of one street tree shall be required for each 40 or 50 feet of street length, depending on the size of the trees, unless existing trees will be preserved to serve the same purpose.

(19) Off-Street Parking and Loading Regulations. The requirements of Article 8 apply, except for the following modifications:

- (a) Off-street parking may be shared by various uses and lots within the RRO district, provided that the developer shall demonstrate to the planning commission that sufficient parking is provided on the tract that is within 500 feet of walking distance from the pedestrian entrance of the use that is served by the parking. The applicant shall prove that shared parking will continue to be available to all of the uses that are served by the parking during the life of those uses.
- (b) The amount of off-street loading requirements shall be determined by the planning commission upon review of the proposed uses of each phase of the master plan.
- (c) Under the authority to modify requirements as part of a PRD, the planning commission may reduce the required amount of off-street parking by up to 20% based upon:
 - [1] The applicant's traffic study and parking study;
 - [2] The ability of various uses to share parking, particularly if those uses have different period time periods of peak parking demand; and
 - [3] The availability of public transit and/or any shuttle service that may be provided during periods of peak parking demand.

- (d) For development under the RRO district, new off-street vehicle parking spaces shall not be located within 50 feet from the top of the bank of the Lehigh River or a structural wall along the Lehigh River, based upon conditions that will exist after the development is completed, based upon the approved final PRD plan.
- (e) An applicant may meet a maximum of 25% of the off-street parking space requirements for each use by counting new on-street spaces adjacent to the curb along a street adjacent to the use.

(20) PRD Modifications. Specific zoning and land development and subdivision regulations that apply to a PRD application may be modified by the planning commission after receiving a written request from the applicant where the applicant proves that an alternative standard would meet the same public objective and would serve the purposes for a PRD as provided in state law. Such modifications shall be limited to street standards, setback requirements, sidewalk and curb standards, and technical engineering requirements. The planning commission shall consider recommendations of the city engineer before approving any modifications to street and rights-of-way requirements. Applications may also be made for a zoning variance, in the same manner as would apply to other sections of this zoning ordinance.

(21) Preserved Open Land. The method of ownership and maintenance of the preserved open land shall be approved by the planning commission as part of the PRD approval. Any later changes to the preserved open land ownership or use that was not part of the PRD approval shall need planning commission approval.

- (a) Required preserved open land shall be preserved through a permanent conservation easement that is enforceable by the city. The legal form of the documents concerning the preserved open land shall be approved by the city Solicitor.
- (b) The preserved open land shall be improved so that it is suitable for its intended use, including the planting of trees and shrubs where existing trees and shrubs will not be maintained.
- (c) Methods for ownership of the preserved open land shall utilize one of the following:
 - [1] Dedication to the city for public recreation if the city agrees in advance to accept it;
 - [2] Dedication to a property owners' association, with each owner of property within the PRD legally required to annually fund their share of the maintenance of the open land;

- [3] Retention by the owner of a rental housing development; or
- [4] Another suitable method that is specifically approved by the planning commission.

660-08.H MUO, MIXED-USE OVERLAY

(1) Boundary. The MUO zone applies within the geographic overlay boundaries depicted on the official zoning map.

(2) Purposes. The MUO district is intended to:

- (a)** Serve the purposes provided in the Pennsylvania Municipalities Planning Code (MPC) for Planned Residential Developments (PRDs) and for Traditional Neighborhood Developments (TNDs);
- (b)** Promote a coordinated mix of residential, business, institutional, recreational and open space uses in a manner that is pedestrian-friendly, transit-friendly and bicycle-friendly;
- (c)** Widen housing opportunities in the city, particularly for housing types that are in high demand;
- (d)** Be designed to properly relate to existing adjacent neighborhoods, and
- (e)** Includes a system of preserved open lands and trails, including preserved open lands that are integrated with residential areas.

(3) Applicability and Phasing.

- (a)** The MUO district is an optional district that overlays the underlying zoning district. An applicant shall have the option of developing property under the MUO district or under the underlying zoning district. Once a PRD Final Plan is approved under the MUO district, such land area shall be developed under the MUO district provisions, unless the applicant abandons the PRD Plan approval in writing or the PRD Plan approval is determined in writing by the city to have expired.
- (b)** Development in the MUO district shall first require approval as a PRD. The PRD approval process under the Municipalities Planning Code replaces the city's land development and subdivision approval process. Once a phase of a PRD has been granted Final Plan approval by the city planning commission, then individual uses allowed in the MUO district shall be permitted by right within that phase, provided they are consistent with the approved PRD Final Plan. If uses or development are proposed that are inconsistent with the approved PRD Final Plan, then the applicable PRD Final Plan revisions shall first be approved by the planning commission. However, a Tentative Plan revision is not required for

engineering details and related revisions in a Final Plan that do not affect the densities, types of uses, or overall street and open land layout contained in such Final Plan.

(c) The provisions of this MUO district shall only be available to be utilized if there is a minimum of 20 adjacent acres of land in common ownership at the time of PRD Tentative Plan submission. Each phase of development shall be designed to be able to function properly even if later phases of the PRD are not completed. A Declaration of Restrictive Covenants, conditions on approvals, notes on the approved plans, and/or a Development Agreement shall address responsibilities if phases of development are undertaken by two or more different entities. The various phases of the PRD shall be coordinated in uses and transportation access. Each phase shall include a minimum of 3 acres.

(4) Use Regulations. "Adult uses" are specifically prohibited. "Betting Uses" are specifically prohibited. When approved under the MUO district, land and/or structures shall only be used for the permitted by right uses listed below (unless a use is specified as needing special exception approval below), after Final Plan approval has been granted as a PRD. The following uses shall also meet any applicable additional requirements for the use in this zoning ordinance, including applicable supplemental regulations of Article 4.

- (a)** Single family detached dwellings, twin dwellings or two-family dwellings.
- (b)** One or more apartment/multi-family dwellings within a building that includes a principal nonresidential use.
- (c)** Multi-family dwellings, including three or more dwelling units on a lot.
- (d)** Rowhouse/townhouse.
- (e)** Sample or model home.
- (f)** Art gallery.
- (g)** Bed-and-breakfast inn.
- (h)** Business services.
- (i)** Catering, preparation of food for (this use may be combined with a restaurant if the requirements for a restaurant are also met).
- (j)** Commercial communications tower/ antennas that extend up to 25 feet above a principal nonresidential building, water tank, or electric transmission tower. Small Cell Antennas shall also

be allowed in conformance with the city Code provisions in Chapter 545 for "Small Cell Antennas."

- (k)** Custom crafts, manufacture and sale of (such as jewelry and handicrafts), or artisan's studio retail craft shops such as, but not limited to, artisan shops, glass blower shops, ceramic tile maker shops.
- (l)** Exercise club, or fitness facility, and/or an indoor or outdoor swimming pool.
- (m)** Financial institution, which may include a drive-through facility.
- (n)** Hotel or motel, which may include a restaurant and conference center.
- (o)** Massage establishment involving services by a State-licensed Massage Therapist. All other commercial uses involving massages in private rooms shall be prohibited.
- (p)** Offices of business, institution, profession, medical, or similar entity.
- (q)** Personal services (such as barbershops, beauty shops, laundry and dry cleaning pickup and delivery, and closely similar uses).
- (r)** Printing and duplication, commercial.
- (s)** Recreation, commercial, indoor or outdoor.
- (t)** Restaurant, without drive-through service.
- (u)** Retail store.
- (v)** Shopping center.
- (w)** Tavern or nightclub, which may include a brewpub, micro-distillery or custom winery, which may include on-site consumption and retail sales for off-site consumption.
- (x)** Theater, civic and/or cultural facility, arena, gymnasium, auditorium or sports stadium.
- (y)** Trade school or similar educational institution.
- (z)** Veterinarian or animal day care, but not including an overnight kennel.
- (aa)** Research and development, engineering or testing facility or laboratory.
- (ab)** Adult day-care center.
- (ac)** Child-care center, nursery school, preschool or "Head Start" program center.
- (ad)** College or university, not including a dormitory.
- (ae)** Museum or visitor's center, and which include accessory retail sales.
- (af)** Nursing home, assisted living residence, hospital or personal care home, provided each shall be licensed as applicable by the State of Pennsylvania.
- (ag)** Community center, non-profit.
- (ah)** Government uses, not including: prisons, other correctional facilities and solid waste facilities.
- (ai)** Membership club.
- (aj)** Place of worship, which may include an accessory day care center.
- (ak)** Public park, playground or other publicly-owned recreation facilities or non-commercial outdoor recreation areas, such as areas owned by a homeowner association.
- (al)** Swimming pools, household or non-household, public or private.
- (am)** Bus passenger shelters.
- (an)** Small group home, which shall need special exception approval.
- (ao)** Parking, off-street, public or private, surface, underground or structured, as a principal or accessory use of lot.
- (ap)** Public utility, such as electric substations, wastewater pump stations or water tanks, but not including vehicle garages, warehouses, or outdoor storage yards. This use may also include utility facilities owned by a property-owner association.
- (aq)** Accessory use and/or structure on the same lot and customarily incidental to a lawful principal use.
- (ar)** Family child-care home.
- (as)** Group child-care home.
- (at)** Solar energy collection devices; Electric vehicle recharging stations as a customary accessory use.
- (au)** Home occupation.
- (av)** Manufacturing as a routine and customary accessory use to the permitted principal use of the lot (see also "custom crafts").
- (aw)** Warehousing as a customary accessory use to a permitted principal use of the lot.
- (ax)** Schools, elementary or secondary, public and private.
- (ay)** A maximum of 5 percent of the total land area of the PRD may be used for the following business uses, provided that such buildings shall be setback a minimum of 400 feet from any pre-existing dwelling unit structure in a residential district and a

minimum of 200 feet from any proposed dwelling unit structure within the PRD:

- [1] Moving and related storage business as a principal or accessory use.
- [2] Offices, accessory warehousing and primarily indoor storage for a building tradesperson business.
- [3] Flexspace buildings, which shall mean buildings including a combination of business uses that are permitted by right within a PRD, such as an office and sales area in the front of the building and an accessory warehousing area or building tradesperson use in the rear of the building.
- [4] Manufacture of food or beverage products for human consumption, wood products, electrical or electronic products, or glass products.
- [5] Industrial equipment sales and service, such as forklifts, conveyor belts and similar equipment.
- [6] Manufacture or processing of products from materials manufactured off-site, such as from plastics, metals, glass or textiles.
- [7] Packaging, bottling or assembly.

(5) Area, Yard and Building Regulations. The following area, yard and building regulations shall apply for all uses, whichever is most restrictive.

- (a) Maximum Overall Residential Density.** Residential density shall not exceed 30 dwelling units/acre for any phase of the PRD. The maximum overall residential density for the entire PRD shall be a maximum of 10 dwelling units/acre, based upon the total area of the tract. The maximum residential density shall be based upon the "total area of the tract", before the deletion of rights-of-way of proposed streets and before the deletion of proposed open land. Lots that are developed for business uses without any residential uses shall not count towards the overall residential density. Individual lots may exceed the maximum overall residential density, provided that the applicant proves that the maximum overall density for the entire PRD will continue to be met after the completion of each phase of development. For a nursing home, personal care home or assisted living facility, every 4 resident beds shall count as one dwelling unit, for the purposes of determining the maximum density.
- (b) Minimum Lot Area.** 1.5 acres minimum for a principal industrial use or a principal institutional use. Minimum lot area of 5,000 square feet for a lot including one or more principal commercial or

multi-family residential uses. Minimum lot area of 1,200 square feet for other lots. Lot dimensional requirements shall not apply to a lot that is only used for a water supply, air quality monitoring, wastewater pumping, electrical sub-station or stormwater facility or for a non-commercial outdoor recreation area or trail, provided that the lot shall have access for maintenance.

- (c) Minimum Lot Width and Minimum Building Width.** 150 feet for an industrial use, and 20 feet for other uses. Each single family detached dwelling, single family semi-detached dwelling, townhouse or commercial use shall have a minimum building width of 20 feet. Individual uses or buildings may be owned in a condominium arrangement, which may include shared parking and common maintenance of outdoor areas, without each condominium unit needing to meet the minimum dimensional requirements (such as lot width and yards), provided that the applicant shows that the development would have been able to meet the dimensional requirements as if individual fee-simple lot lines had been established. Where condominium ownership is proposed, a Declaration of Restrictive Covenants shall be established as a condition of Final Plan approval, for the respective phase.
- (d) Minimum Building Setback From PRD Tract Perimeter.** 20 feet, except a minimum of 40 feet from the lot line of a pre-existing dwelling in a residential district outside of the PRD for a proposed building of greater than 40 feet in height or for a multi-family residential building.
- (e) Minimum Front Setback.** Zero feet. The intent is that new principal buildings should be placed within a maximum of 50 feet from the street right-of-way line along the primary street frontage, unless a wider space is needed for an outdoor pedestrian plaza or outdoor cafe. A dwelling may be designed to front upon improved vegetated open land with a sidewalk or pathway and vehicle access using a rear alley or a street, without necessarily requiring frontage onto a street.
- (f) Minimum Rear Setback.** 8 feet, except 25 feet from a proposed principal nonresidential building to the lot line of a principal residential use on another lot, and except 3 feet for a structure that is accessory to a dwelling.
- (g) Minimum Side Setback.** 3 feet, except: 1) zero feet where buildings are approved to be attached within the development, 2) 20 feet from a proposed principal nonresidential building to the lot line of

a principal residential use on another lot, and 3) where a larger perimeter setback is required by subsection (d) above.

- (h) Notwithstanding the setback requirements of (d), (e), (f) and (g) above, stormwater water controls shall: (1) have a setback consistent with the requirements of Chapter 355 Land Development Controls, and (2) shall not be required to meet zoning setbacks. Stormwater conveyance improvements are not required to have a setback from a property line, if approved by the city engineer, and 2) grading may occur up to the property line.
- (i) **Maximum Building Coverage.** 70%. The maximum building coverage shall be based upon the ground level footprint of all buildings on the tract divided by the total area of the tract. Individual lots may have a higher building coverage, provided that the maximum is not exceeded for the tract. The city may require that certain lots include a deed restriction and notations on the approved plans limiting their maximum coverage to ensure that the maximum overall coverage requirement is met across the tract over time.
- (j) **Maximum Building Height.** 4 habitable stories or 65 feet, whichever is more restrictive. A building may also include a floor level that is partly or entirely below ground that is primarily used for vehicle parking or a basement that is used for storage and mechanical equipment.
- (k) **Buffer Strip.** Not required, except a ten feet wide planted buffer strip shall be required if a pre-existing principal dwelling in a residential district that is not within the PRD tract is adjacent or across a street or alley from a new principal nonresidential use, nonresidential use parking lot or multi-family building. A minimum five feet wide buffer strip shall also be required between a new principal business use and a proposed or existing principal residential use on another lot within the PRD. The buffer strip shall be planted and maintained with an attractive and continuous landscape screen. The landscaping shall consist of primarily evergreen trees and shrubs with a minimum height when planted of 3.5 feet and in such numbers, locations and species as can reasonably be expected to produce, within three growing seasons, a year-round mostly continuous complete visual screen at least five feet in height.
- (l) Each single-family detached, twin and townhouse dwelling shall have a private outdoor area including a minimum area of 400 square feet for the

exclusive use of that dwelling unit. Such outdoor area may be a rear or side yard, a courtyard, a porch, a balcony, a deck, an improved rooftop recreation area with railings, or a similar feature.

- (m) Open-sided solar panel canopies may be constructed over approved vehicle parking areas without needing to meet principal setback requirements and without being regulated by the zoning ordinance as a building. Solar panel canopies shall meet accessory structure setbacks and shall not be allowed within the minimum front yard.
- (6) **Uses Allowed in Underlying District.** The applicant shall have the option of developing a use under the regulations of the underlying zoning district, instead of the provisions of the MUO district. In such case, all of the regulations of the underlying district shall apply instead of the regulations of the MUO district. Once a final PRD plan has been approved for a phase, then within the land area of that phase, only uses that are allowed in the MUO district shall be allowed.
- (7) **Minimum Nonresidential Uses.** A minimum of 10 % of the total land area of the tract after completion of the development shall be occupied by principal non-residential uses and their parking, after deleting proposed open land from the calculation of total land area of the tract. Such land area may also include upper story dwellings. See also Section E.(1) below which sets a minimum size for a required pedestrian-oriented commercial area.
- (8) **Open Land.** A minimum of 35% of the total land area of the PRD shall be preserved as open land that is available for active and passive outdoor recreational use by the residents and employees of the tract, or by the general public. Such open land shall include a landscaping and trail plan that takes into account existing healthy concentrations of trees and any areas proposed for outdoor recreational facilities. Such open land shall be regulated by a conservation easement or deed restriction established by the applicant and enforceable by the city of Allentown or its designee, which prohibits the construction of non-recreational buildings and the further subdivision of the required open land. The required open land is not required to be contiguous with each phase of development, provided that sufficient vehicle and pedestrian access is provided to the open land.
 - (a) Outdoor recreational facilities shall be landscaped and may include sidewalks, pathways, and structures typically included in active and passive recreational areas. Areas used for buildings or

vehicle parking shall not count towards the open land requirement, except: 1) areas for rooftop active recreation facilities that are available to all residents of the phase may count as open land areas, and 2) a non-commercial recreation building or parking necessary to serve recreation facilities may count towards the open land requirement.

- (b) See Section K. below regarding ownership.
 - (c) The majority of the open land shall be focused on providing for non-motorized recreation trails, active and passive recreation, and the preservation of environmental sensitive areas. The open land shall also include areas designed to take advantage of scenic views.
- (9) Trails.** The MUO district offers flexibility to the developer as an optional form of development. In return for such flexibility, a developer shall only be eligible to use this MUO district if the developer commits to providing a public trail system, which shall be open for public pedestrian access from sunrise to sundown, at a minimum. Such public access shall include a pedestrian trail with a typical minimum width of 8 feet and a public pedestrian access easement with a typical minimum width of 12 feet. Such pathway may also be open to maintenance vehicles and bicycles. Such trail may be gated and closed to the public between sunset and sunrise. The main trails shall include hard surfaces or compacted crushed stone that are designed to be usable by wheelchairs, but nature trails may also be provided in sloped areas of the preserved open land that are not hard-surfaced and not ADA-compliant.
- (10) Fire Access.** The applicant shall prove to the satisfaction of the planning commission, after a review by the city Fire Department, that all buildings will be adequately accessible by fire apparatus. There shall be at least two entrances into the tract for fire trucks. The city may require that buildings be sufficiently separated to allow firefighting access. Where streets do not provide adequate access to sufficient sides of a building, the city may require that a pedestrian pathway be constructed with sufficient paving depth and width so that the pathway will be suitable for use by fire trucks. Where there is no need for a pathway, the city may require other provisions for fire truck access, such as a stabilized surface under grass for fire access.
- (11) Site and Building Layouts; Signs; Slopes.**
- (a) The PRD shall include at least 2 acres that includes commercial uses and that is intended to accommodate pedestrian travel between uses. Such area may also include dwelling units or allowed business uses on the upper stories. Such 2

acre requirement may be met as part of any phase of the development.

- [1] Within this pedestrian-oriented commercial section, off-street vehicle parking shall not be allowed between the front of the commercial buildings and the adjacent front street right-of-way line. If a commercial building abuts more than one street, this parking restriction shall only apply abutting one of the streets. The required off-street parking for these commercial uses shall be provided to the side or rear of the buildings or on another lot or using on-street parking spaces.
 - (b) Outdoor garbage collection facilities shall be surrounded by a decorative enclosure or plant screening. Business truck loading docks shall be screened from pedestrian view along the front street right-of-way line and from existing dwellings outside of the PRD and proposed dwellings on other lots within the PRD.
 - (c) A minimum of two streets shall enter the tract after completion. At least one inter-connected vehicle route shall extend through the bulk of the interior of the tract. The tract should have a central focal point, such as a landscaped central green space.
 - (d) For portions of the PRD that are entirely residential, the sign regulations shall apply that would otherwise apply to the R-M district, or its successor zoning district. For other portions of the PRD, the sign regulations shall apply that would apply to the B-2 district, or its successor zoning district.
 - (e) The regulations regarding development on steep slopes shall not apply to areas of steep slopes that the applicant shows were clearly man-made, such as areas that were graded previously for buildings, basins, quarrying or other features. The alteration of all slopes shall result in stable conditions.
- (12) Submission and Approval Process.** Development under the MUO district shall require approval by the planning commission as a Planned Residential Development (PRD). The requirements and procedures for a PRD of the Municipalities Planning Code are hereby included by reference.
- (13) Master Plan.** The applicant should first submit an overall Master Plan for the tract. The Master Plan should be to drawn to scale, at a level of detail typically found at a Sketch Plan stage. The Master Plan shall be offered for review and comment by the planning commission, bureau of planning and zoning, and bureau of engineering, and shall require approval by resolution by the planning commission.

(a) The Master Plan may propose a range of allowed uses in various areas, as opposed to identifying each specific use. The Master Plan should show the preliminary layout of streets, alleys, lots, public trails, recreation areas, major pedestrian and bicycle pathways, maximum heights of buildings, parking areas, major detention basins, and proposed types of housing and nonresidential uses.

- [1] The Master Plan is intended to show the interrelationships and compatibility of various elements of the PRD.
- [2] A Tentative Plan submittal shall be made that includes all of the land within the proposed PRD. The Tentative Plan submittal shall meet all of the submission requirements that are provided in Section 707(4) of the Municipalities Planning Code, as well as sufficient information to show the feasibility of the proposed access points from existing public streets. The Tentative Plan shall include the following information:
 - [i] The location, size and topography of the site and the nature of the landowner's interest in the land proposed to be developed;
 - [ii] The density of land use to be allocated to parts of the site to be developed;
 - [iii] The location and size of the preserved open land and the form of organization proposed to own and maintain the preserved open land;
 - [iv] The type of uses and housing in each land area and the approximate height, bulk and location of buildings and other structures, and the preliminary layout of lots, trails, recreation areas, major pedestrian and bicycle pathways, and major detention basins;
 - [v] Sufficient information to show the feasibility of proposals for water supply and the disposition of sanitary waste and storm water;
 - [vi] The substance of covenants, grants of easements or other restrictions proposed to be imposed upon the use of the land, buildings and structures including proposed easements or grants for public utilities;

- [vii] The provisions for parking of vehicles and the location and width of proposed streets, alleys and public ways;
- [viii] The requested modifications in the land development and subdivision regulations and the reasons for the request;
- [ix] The feasibility of proposals for energy conservation and the effective utilization of renewable energy sources;
- [x] In the case of development plans which call for development over a period of years, a schedule showing the proposed times within which applications for final approval of all sections of the planned residential development are intended to be filed and this schedule must be updated annually, on the anniversary of its approval, until the development is completed and accepted;
- [xi] A written statement by the landowner setting forth the reasons why, in the landowner's opinion, a prd would be in the public interest and would be consistent with the comprehensive plan;
- [xii] A brief narrative describing how the proposed development is being coordinated with adjacent existing development; and
- [xiii] Delineation of streets that are proposed to be dedicated to the city, and streets that will be maintained by a legally binding property-owner association.

(b) The Tentative Plan shall show all information that would be required as part of a Preliminary Plan under the land development and subdivision regulations, except for information listed in this subsection (3). The following information shall specifically not be required to be submitted as part of a Tentative Plan, but instead shall be required as part of the Final Plan submission:

- [1] Stormwater calculations.
- [2] Housing numbering plans.
- [3] Proposed monuments and lot markers.
- [4] Species of plantings for landscaping plans, but the proposed locations of buffer strips and typical placement of street trees shall be shown on the Tentative Plan.
- [5] Profiles of proposed sanitary sewage lines, storm drains and streets, except that the

applicant shall show proposed maximum slopes of streets.

- [6] Designs of culverts, manholes, catch basins, sidewalks and similar construction details, provided that the locations of sidewalks shall be shown.
 - [7] Locations of proposed electric, telephone and cable television lines and water and sewage laterals.
 - [8] Lighting plans.
 - [9] Detailed cross-sections are not required for all streets, but typical cross-sections shall be provided.
 - [10] Detailed grading plans are not required for individual buildings, but typical grading plans shall be provided.
- (c) The Tentative Plan may include a range of allowed business uses in a specific area, as opposed to identifying each specific use. The Tentative Plan may include two alternatives for a specific land area, such as having one layout for townhouses and one layout for twin homes, provided the alternative does not affect the location of public streets. Where two alternatives are shown in the Tentative Plan, one of those alternatives shall be chosen as part of the Final Plan.
- (d) The Tentative Plan shall be to scale and be designed to show how the PRD will comply with this zoning ordinance. The Tentative Plan is not required to show compliance with Chapter 355 Land Development Controls, provided compliance will be addressed prior to approval of the PRD Final Plan or prior to earth disturbance for a phase of development, whichever occurs first.
- (e) After a Tentative Plan has been approved, a PRD Final Plan shall be submitted, which may occur in phases. The Final Plan shall need approval by the planning commission.
- [1] No sale of lots or construction of buildings shall occur until after: 1) an approved PRD Final Plan has been approved by the planning commission and has been recorded, 2) the applicant has proven they have met any conditions upon approval, and 3) acceptable financial guarantees for improvements have been established.
 - [2] A PRD Final Plan shall meet all of the requirements of this zoning ordinance and Chapter 350, Land Development and Subdivision Regulations, that are not specifically

modified by this section or by the provisions of the Municipalities Planning Code that governs PRDs. If a Preliminary Plan requirement was exempted from the PRD Tentative Plan submission, such requirement shall be met as part of the PRD Final Plan.

- (f) After the Final PRD Plan has been approved, zoning permits for individual uses and buildings may be approved, subject to compliance with the PRD Final Plan. If a proposed use or structure does not comply with the Final PRD Plan, then such revision to the Final PRD Plan shall be submitted for approval by the planning commission.

(14) Phasing. As each phase of development is granted Final Approval, the applicant shall provide evidence that the requirements of this MUO district will be met, even if later phases of development would not be completed. This shall include, but not be limited to, providing evidence of compliance with the density, coverage and open land requirements. The preserved open land does not need to be contiguous to each phase. Each phase of development shall be developed in full coordination with prior and future phases, to ensure that proper traffic circulation and utility services will be provided, and to ensure general compliance with the Tentative Plan.

- (a) If a particular Final Plan is not generally consistent with the approved Tentative Plan, then the applicant shall submit a revision of that portion of the Tentative Plan for approval by the city planning commission. However, the approved Tentative Plan is not required to be revised for matters addressed in the Final Plan that do not affect compliance with these PRD requirements, such as adjustments in street alignments or changes in building shapes to reflect more detailed design.

(15) Architecture. To carry out the intent of Traditional Neighborhood Development, prior to a phase receiving Final PRD approval, the applicant shall submit the substance of draft architectural covenants to the bureau of planning and zoning, the city solicitor's office and the city planning commission for review and comment. Such provisions shall be prepared with the involvement of a registered architect. The applicant shall establish a set of architectural covenants as a condition of Final Plan approval, prior to the recording of such plan. As part of zoning permit applications, an architectural sketch of the front facade of nonresidential principal buildings and multi-family buildings shall be submitted to the bureau of planning and zoning for review. Architectural covenants recorded for the site shall supersede any applicable building design standards in Article 6.

(16) Covenants. The city may also require covenants, deed restrictions, or conditions upon a Final PRD Plan to address setbacks, landscaping, pedestrian access, fire access, and other matters necessary to carry out the intent of this Section.

(17) Public Access. The Final Plan shall describe the locations and extent of public access to trails and preserved open lands.

(18) Traffic Study and Improvements. As part of the Tentative Plan submittal, the applicant shall submit a traffic impact study to the city, which shall be prepared by a qualified professional. Such study shall assess current traffic conditions, the amount of traffic expected to be generated by the total development, the impacts upon traffic, and improvements that the applicant proposes to complete or fund. Such traffic impact study shall be updated as needed as each phase is submitted. If diagonal parking is proposed along a street, the traffic impact study shall assess the safety of such parking in that location.

(a) The applicant shall prove that the level of service of traffic will not be reduced below a level of D for adjacent existing public street intersections as a direct result of the new development. This level of service analysis shall consider traffic improvements that the applicant commits to fund as well as projects that are officially programmed for funding by the State.

[1] This Subsection G(5)(a) may be modified by the planning commission if the applicant proves that a reduction in level of service is unavoidable because the applicant, the State and the city do not control sufficient right-of-way to make the needed traffic improvement.

[2] Prior to granting a modification of this Subsection G(5)(a), the planning commission shall determine that evidence has been provided to them to show that the level of service will not result in congestion that would be a threat to public safety.

(19) Land Development and Subdivision Requirements. As authorized under the TND and PRD provisions of the Municipalities Planning Code, the planning commission may grant modifications to the specific street, improvement and other requirements of Chapter 350, Land Development and Subdivision, for development within the MUO district in response to a written request by the applicant. These modifications may include alternative standards for various types of streets that are based upon recommendations of PennDOT Design Manuals, the American Association of

State Highway and Transportation Officials, the Institute of Transportation Engineers and similar professional organizations.

(a) The following are examples of street right-of-way and cartway widths that are intended to be approved for new streets, in addition to options that are allowed under Chapter 350, and Land Development and Subdivision:

[1] A collector street with two-way traffic may be constructed with two travel lanes of 11 feet each, diagonal parking lanes of 18 feet each or eight feet wide parallel parking lanes if parking is allowed, a planting strip with street trees on each side of the street (which may utilize tree wells), pedestrian sidewalks or pathways on each side of the street, and a right-of-way width that extends a minimum of ten feet on either side of the curblin. A collector street may also include a turn lane where warranted.

[2] A local street with two-way traffic may be constructed with two travel lanes of 10 feet each, eight feet wide parallel parking on one or both sides, a planting strip (which may utilize tree wells) with street trees on each side of the street, pedestrian sidewalks or pathways on each side of the street and a minimum right-of-way width that extends a minimum of ten feet on either side of the curblin.

[3] An alley serving two-way traffic may be constructed with a 16 feet wide cartway and an eight feet minimum setback between the travel lane and any rear garage. Any alley shall be required to be maintained by a homeowner association and shall be designed to prevent use of the alley by through-traffic.

[4] The planning commission may require wider cartway widths as needed, considering the results of the traffic impact study. All streets shall include a right-of-way, including private streets, and which shall be used for measuring required setbacks.

(b) Any street within the MUO district, whether public or private, shall meet the same minimum construction material requirements as would apply to any new street intended to be dedicated to the city under city ordinances, unless a modification is specifically approved by the planning commission.

[1] All private streets shall include an easement or right-of-way.

- (c) After receiving a recommendation from the city engineer, the city planning commission may approve a requested modification to allow a portion of a local private street to have a slope greater than provided in the land development and subdivision regulations.
 - (d) Pedestrian sidewalks meeting Americans With Disabilities Act requirements shall be required on each side of every street that serves through-traffic, unless the planning commission approves an alternative pathway system that provides sufficient connectivity. Sidewalks shall have a minimum width of 5 feet in residential areas and sidewalks shall have a minimum width of 6 feet in commercial and institutional areas.
 - (e) The street tree requirements in the zoning ordinance shall apply, provided there shall be flexibility in the locations of the required street trees, and provided the locations are approved by the city planning commission. For example, street trees may be approved to be placed immediately outside of a right-of-way or in an immediately adjacent area of open land. Sufficient space shall be provided for each street tree to thrive, which may include a vegetated surface, use of porous pavers near a tree, a tree grate or a tree well around the street tree.
 - (f) The minimum centerline radius for a local residential street may be reduced to 125 feet.
- (20) Parking and Loading.** The off-street parking and loading requirements of this zoning ordinance shall apply, except for the following modifications:
- (a) Off-street parking may be shared by various uses and lots within the MUO district, provided that the developer shall demonstrate to the zoning officer that sufficient parking is provided on the tract that is within 500 feet of walking distance from the pedestrian entrance of the use that is served by the parking. The applicant shall prove that a method will be in place to guarantee that the shared parking will continue to be available within the required distance to all of the uses that are served by the parking during the life of those uses, such as a deed restriction or long-term lease.
 - (b) Off-street loading. Section 660-75 or its successor section shall apply.
 - (c) Under the authority of the MPC to modify requirements as part of a PRD or TND, the planning commission may reduce the required amount of off-street parking by up to 15% based upon the following considerations:
 - [1] The applicant's traffic study and any parking study that is provided;
 - [2] Evidence that is provided regarding the ability of various uses to share parking, particularly if those uses have different period time periods of peak parking demand;
 - [3] The availability of public transit and/or any shuttle service that may be provided during periods of peak parking demand; and
 - [4] Data on parking demand that is provided based upon research of the Institute of Transportation Engineers or similar professional studies of developments.
 - (d) An applicant may meet a maximum of 20% of the off-street parking space requirements for each use by counting new on-street spaces adjacent to the curb along a new street adjacent to the use. Each space shall only be allowed to be counted once to serve one use.
 - (e) As part of each phase of development and each zoning permit application for a new use or change of use, the parking requirements calculations shall be updated as needed, and submitted to the zoning officer.
- (21) PRD Modifications.** Specific land development and subdivision regulations that apply to a PRD application may be modified by the planning commission after receiving a written request from the applicant where the applicant proves that an alternative standard would meet the same public objective and would serve the purposes for a PRD and/or Traditional Neighborhood Development, as provided in the Municipalities Planning Code. This may include, but shall not be limited to, modifications of street standards to allow a site design that is more pedestrian-friendly or that reduces environmental impacts. The planning commission shall consider any recommendations of the city bureau of engineering and/or bureau of planning and zoning regarding modifications.
- (22) Preserved Open Land.** The proposed uses and method of ownership and maintenance of the preserved open land shall be approved by the planning commission as part of the PRD approval. Any later changes to the preserved open land ownership or use that is inconsistent with the PRD Final Plan approval shall need planning commission approval in advance.
- (a) Required preserved open land shall be preserved through a permanent conservation easement that is enforceable by the city. The legal form of the

documents concerning the preserved open land shall be approved by the city Solicitor.

- (b)** The preserved open land shall be improved so that it is suitable for its intended use, including the planting of trees and shrubs where existing trees and shrubs will not be maintained.
- (c)** If there is mutual written agreement between the applicant and the city, part or all of the open land may be maintained as a public park.
- (d)** Methods for ownership of the preserved open land shall utilize one or more of the following:
 - [1] Dedication to the city for public recreation if the city agrees in advance to accept it;
 - [2] Dedication to a property owners' association, with each owner of property within one or more phases of the PRD being legally required to annually fund their share of the maintenance of the open land, and with the form of the property owners' legal documents being subject to review by the city Solicitor;
 - [3] Retention by the owner of a rental housing development; or
 - [4] Another suitable method that is specifically approved by the planning commission, such as management by an environmental conservancy organization that is acceptable to the planning commission.
- (e)** Stormwater detention basins shall not be counted towards the minimum amount of preserved open land unless the applicant proves to the satisfaction of the planning commission that a particular area has been designed to serve a valid recreation purpose during the vast majority of weather conditions, or that a retention basin has been designed to serve as a scenic asset with pedestrian access. A water supply tank, wastewater pumping station or closely similar utility structures shall not count towards the minimum preserved open land. The open land may include areas used for stormwater infiltration or stormwater spray irrigation.”

[page intentionally blank]

ARTICLE 3. BUILDING TYPES

660-09 Applicability 3-2
660-10 Intent 3-2
660-11 Other Applicable Regulations 3-2
660-12 General to All Building Types 3-3
660-13 Outdoor Sites 3-7
660-14 Storefront Building 3-9
660-15 Commercial Center 3-17
660-16 General Building 3-25
660-17 Small General Building 3-31
660-18 Town Rowhouse 3-37
660-19 Urban Rowhouse 3-43
660-20 Lane Rowhouse 3-49
660-21 Suburban Rowhouse 3-55
660-22 Twin House 3-61
660-23 House A 3-67
660-24 House B 3-73
660-25 House C 3-81
660-26 Workshop Building 3-85
660-27 Civic Building 3-91

660-09 Applicability

The regulations of this article, Article 3, apply to all buildings and sites, unless otherwise expressly stated.

660-10 Intent

660-10.A PRESERVE ARCHITECTURAL CHARACTER

The building type regulations are intended to preserve the architectural character and identity of the neighborhoods, districts, and corridors of the city, while allowing for modernization, flexibility of use, improvement of the physical quality of buildings, and increasing the long-term value and sustainability of buildings.

660-10.B PROMOTE BUILDINGS FOR PEOPLE

The building type regulations are intended to enhance the pedestrian experience and protect the historic, human-scaled building form of the city by promoting clearly articulated, well-organized facades along public ways and yielding building proportions and details comfortable to and in line with the scale of people.

660-11 Other Applicable Regulations

660-11.A HISTORIC DISTRICT REGULATIONS

All buildings located within a historic district established by Chapter 328 of the City Code are subject to the regulations of Chapter 328 and review by the Historical Architectural Review Board (HARB).

660-11.B USES

Except as defined in the building type regulations and overlay zones, uses are allowed by zone, subject to the regulations of Article 4.

660-11.C ACCESSORY USES & STRUCTURES

Except as defined in the building type regulations, accessory uses and structures are subject to the regulations of Article 5.

660-11.D EXISTING BUILDINGS AND LOTS

See Article 12 for buildings constructed and lots established prior to the adoption of these regulations that do not conform to these regulations.

Table 660-2. Allowed Building Types by Zone

Building Types	MIXED-USE ZONES							NEIGHBORHOOD ZONES					INDUSTRIAL ZONES			PUBLIC & INSTITUTIONAL ZONES		Section	
	MX				GX								IX	IG	IM	P1	P2		
	-D	-C	-S	-N	-D	-C	-N	NX	N1	N2	N3	N4	N5						
Storefront Building	●	●	●	●	-	-	-	-	-	-	-	-	-	-	-	-	-	-	660-14
Commercial Center	-	-	●	-	-	-	-	-	-	-	-	-	-	-	-	-	-	-	660-15
General Building	-	-	-	-	●	●	-	●	-	-	-	-	-	●	●	●	-	●	660-16
Small General Building	-	-	-	●	-	●	●	●	⊙	⊙	⊙	-	-	-	-	-	-	-	660-17
Town Rowhouse	-	-	-	-	-	●	●	-	-	●	-	-	-	-	-	-	-	-	660-18
Urban Rowhouse	-	-	-	●	-	-	●	-	●	-	-	-	-	-	-	-	-	-	660-19
Lane Rowhouse	-	-	-	-	-	-	-	-	⓪	⓪	-	-	-	-	-	-	-	-	660-20
Suburban Rowhouse	-	-	-	-	-	●	-	●	-	-	●	-	-	-	-	-	-	-	660-21
Twin House	-	-	-	-	-	●	●	-	-	-	●	●	-	-	-	-	-	-	660-22
House A	-	-	-	-	-	●	●	●	-	●	●	●	-	-	-	-	-	-	660-23
House B	-	-	-	-	-	-	-	-	-	-	●	●	-	-	-	-	-	-	660-24
House C	-	-	-	-	-	-	-	-	-	-	-	-	●	-	-	-	-	-	660-25
Workshop	-	-	-	-	-	-	-	-	-	-	-	-	-	●	●	●	○	○	660-26
Civic Building	○	-	-	-	●	●	●	-	-	-	-	-	-	-	-	-	●	●	660-27

KEY: ● = Allowed ⊙ = Only on corner lots of A or B streets; in N1 and N2, allowed on interior lots with special exception
 ⓪ = Only if fronting on a C street, unless otherwise stated ○ = Requires special exception approval - = Not allowed

660-12 General to All Building Types

660-12.A ALLOWED BUILDING TYPES

Building types are allowed in zones per [Table 660-2](#). All buildings and site development must comply with one of the building types in this article, unless otherwise expressly stated in these zoning regulations.

(1) Existing Buildings. Some existing buildings may not exactly match a building type allowed within the subject zone (e.g., a rowhouse building in zone that does not expressly allow rowhouses). In such cases, alterations to these existing buildings must be reviewed for compliance with the building type regulations applicable to an allowed building type in the subject zone that most closely matches the existing building.

- (a)** The Civic Building type may be deemed the “closest match” only when the existing building is occupied by a use in the civic and institutional use group.
- (b)** The Lane Rowhouse building type may be deemed the “closest match” only when the existing building meets the lot frontage requirements applicable to a Lane Rowhouse building.
- (c)** Where the Civic Building and Lane Rowhouse types are not the "closest match," the zoning officer must first evaluate the existing building based on its compliance with the following building type regulations and the "closest match" must meet all of the following regulations for that building type:
 - [1] minimum lot width,
 - [2] lot frontage (e.g. fronting an A or B street),
 - [3] and lot location limitations (e.g. only allowed on a corner lot in the zone).
- (d)** In cases where two or more allowed building types are an equal match to the existing building, the zoning officer must allow the building type that permits the highest number of dwelling units to be designated as the closest match.

660-12.B BUILDING REGULATION TABLES

Building type-specific regulations are presented in a series of building regulation tables for each building type. Unless otherwise expressly noted, a “-” in a cell of a building regulation table means there is no requirement or a requirement is not applicable.

660-12.C NUMBER OF PRINCIPAL BUILDINGS

One principal building is allowed per lot, unless otherwise stated in the building type regulations.

660-12.D ACCESSIBLE LOT

A principal building may only be constructed or placed on a lot where the building fronts a street and vehicular access exists meeting the standards of the city's land development and subdivision regulations.

660-12.E PERMANENT STRUCTURES

All buildings must be of permanent construction without a chassis, hitch, or wheels, or other features that would make the structure mobile, unless otherwise expressly stated in this ordinance, and except as follows:

- (1) Temporary Construction Buildings.** Temporary construction buildings are allowed per [660-51.B](#)
- (2) Temporary Food Trucks.** Food trucks are allowed on sites per [660-31.F](#). See [660-13](#) for Outdoor Sites accommodating food truck lots.
- (3) Manufactured/Mobile Home Parks.** See [660-13.D](#) for manufactured home or mobile home park regulations.

660-12.F SENSITIVE ENVIRONMENTAL AREAS

Where sensitive environmental areas, such as steep slopes, floodplains, or valuable tree canopies, prevent a building from being constructed within the build-to zone, the zoning officer may relocate the build-to zone immediately behind the environmentally sensitive area.

660-12.G TREATMENT OF YARDS

All yards must consist of landscape areas, patio space, or sidewalk space, unless otherwise expressly stated. See [660-151](#) for definition of yards. See [Article 7](#) for landscape and site design regulations.

- (1) Parking Locations.** Paved vehicular areas (parking lots, loading areas, drives) must be located per the building type regulations.
- (2) Driveways Crossing Yards.** Paved vehicular areas are limited to specific locations per the applicable zone building regulations. Driveways may cross through yards as follows:
 - (a)** Where permitted as access to the lot, driveways may cross perpendicularly through the front or side street yards, except as otherwise expressly stated.
 - (b)** In all zones, driveways may cross perpendicularly through the side and rear yards to connect to parking on adjacent lots, provided an easement is obtained for access.

660-12.H TRASH & RECYCLING LOCATIONS

All trash, recycling, and other waste storage areas for buildings and sites must comply with the regulations of this subsection, [660-12.H](#). Recycling includes collection of any materials for reuse, including donation collection containers for clothing or goods.

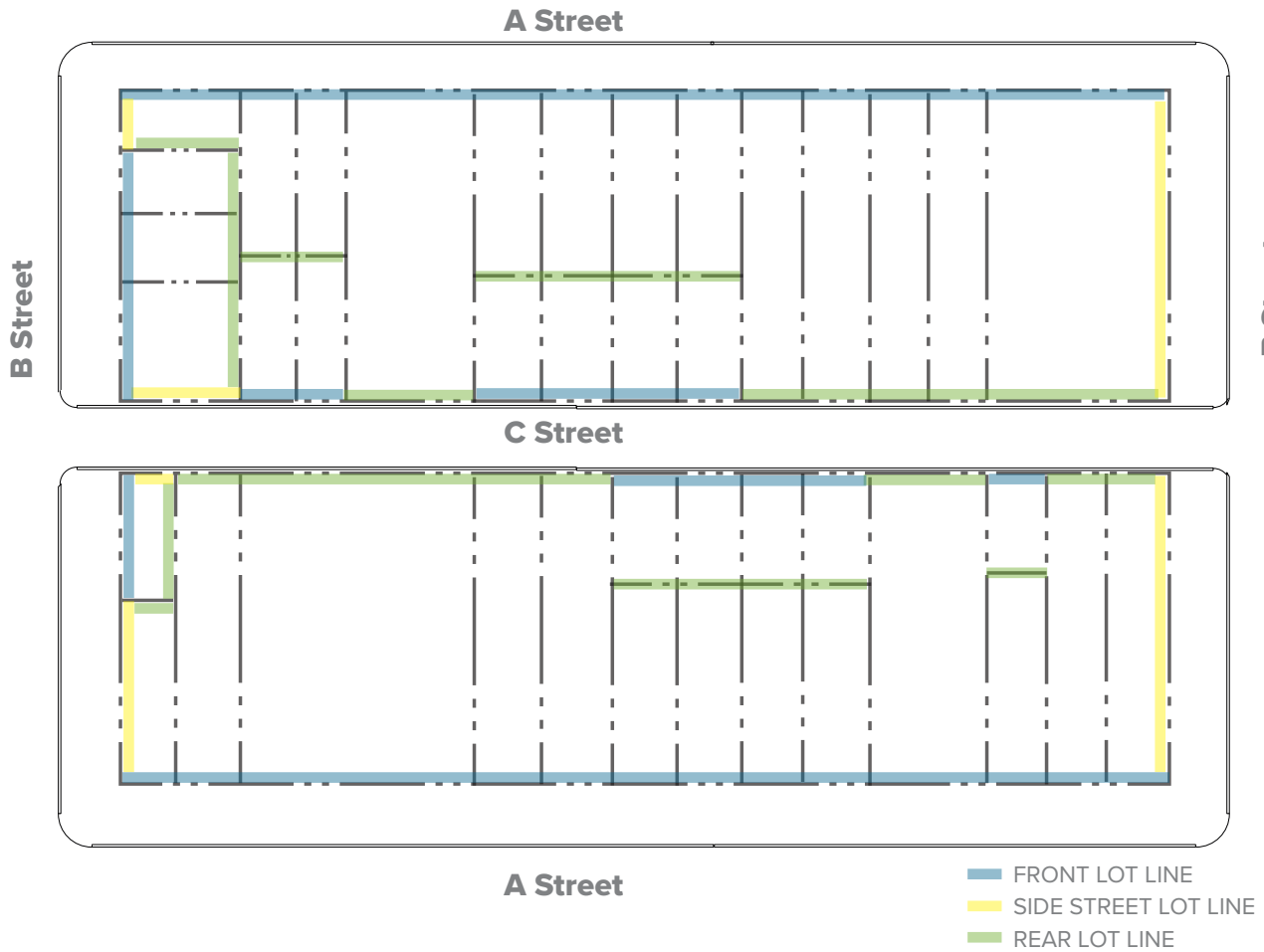

Figure 660-13(2) STREET FRONTAGES

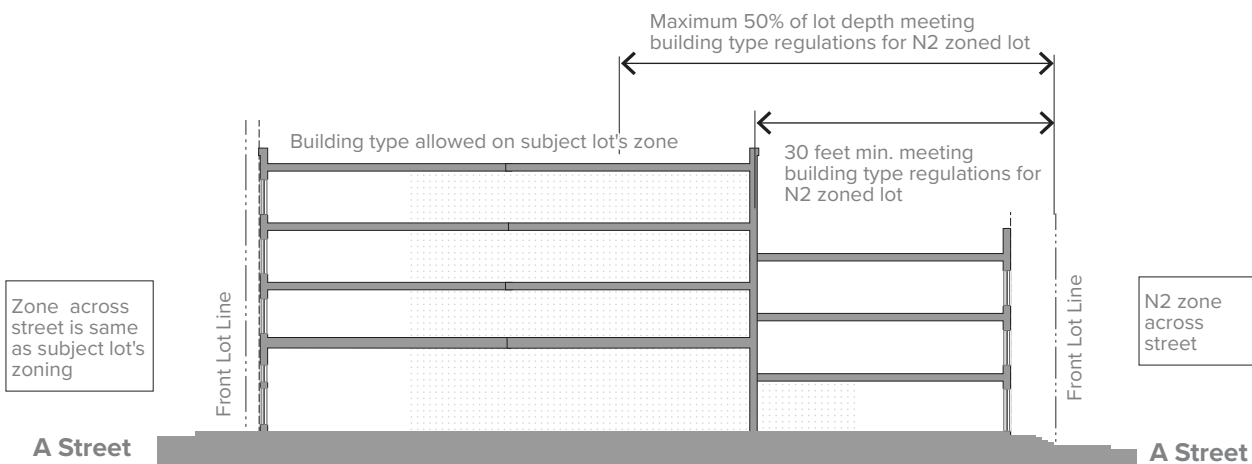

Figure 660-13(1) Example of a Double-Frontage Lot (building section)

- (1) **Rear Yard.** Trash, recycling, and other waste areas must be located in the rear yard of the lot, except as allowed by this subsection, 660-12.H.
- (2) **Other Yards.**
 - (a) When no rear yard exists or when the rear yard is less than 5 feet in depth, trash, recycling, and other waste areas may be located in the rear portion of an interior side yard.
 - (b) When no rear or side yard exists, trash, recycling, and other waste areas may be located in a side-street yard, provided the containers are fully screened from the street by an opaque fence, high enough to fully screen the receptacles from the sidewalk across the street. See 660-39 for fence regulations.
- (3) **Interior Location Access Doors.** Trash, recycling, and other waste areas may be located inside the building with access doors off the rear or interior side facade. Access doors may be located off a B or C street facade if no other option exists. Access doors must be opaque, screening a minimum of 80% of the opening.
- (4) **Concrete Pad.** A concrete pad is required for all loading and refuse areas
- (5) **Screening.** The height of the screen must be tall enough to screen the containers inside and a minimum of 4 feet. The zoning officer may require additional height as needed for complete screening. See 660-73 for additional side and rear buffers.
 - (a) **Opaque Screen.** An opaque wall, such as a building wall or masonry wall, or a fence is required around 3 sides of the area to be screened. The wall or fence may be constructed of masonry or wood; chain link fence without slats is prohibited. If the opening is visible from the street, an opaque gate is required.
 - (b) **Landscape.** If the screen is visible from the street, the zoning officer shall require planting beds consisting of a mixed shrubs with a minimum mature width of 24 inches each, spaced no more than 36 inches on center, and height maintained between 30 and 72 inches planted along the screen.

660-12.I LOADING LOCATIONS

Unless otherwise defined by the building type, all loading areas must be located as follows.

- (1) **Rear Yard.** All loading activities must occur in the rear or interior yard except as allowed in any I zone building types.

- (2) **Access Doors and Docks.** All loading docks and access doors must be located on a rear facade or interior yard facade, except as allowed on any I zone building types.
- (3) **Screening.** See Article 7 for required frontage, side and rear buffers.

660-12.J DESIGNATION OF FRONT STREETS

The determination of fronts of lots is key to the building type regulations, requiring the highest level of facade treatment and restricting the location of parking, driveways, and garage entrances.

- (1) **Establishing the Front, Side-Street, Side, and Rear Lot Lines.** The location of A, B, and C streets abutting a lot generally determines the front, side-street, side, and rear of a lot. Other situations that determine fronts are established in 660-12.J(9).
- (2) **A, B, and C Street Designation.** A, B, and C streets are designated on the streets map for zoning, maintained as a layer on the City's geographic information system (GIS), under the direction of the IT director.
 - (a) **A Streets.** A streets include primary corridors throughout the city and neighborhood streets where the fronts of buildings and principal entrances occur. A streets are considered front streets.
 - (b) **B Streets.** B streets tend to run perpendicular to A streets and are typically considered side streets.
 - (c) **C streets.** C streets are narrower streets and lanes with right-of-way widths of 25 feet or less, that often serve as rear lot access to other properties fronting other streets, utility corridors, and may also include Lane Rowhouses.
- (3) **Zoning Officer Determination.** The zoning officer may determine the front, side-street, side, and rear lot lines of the lot based upon the context, including the location of the lot on the block, location of existing front facades along the street, use of the site, proposed redevelopment, or other planning efforts.
- (4) **Front Lot Line.** All lots must have a front lot line abutting a street right-of-way. Front lot lines are established by one of the following:
 - (a) **A Streets.** A lot line abutting an A street is typically the front lot line, unless otherwise determined by the zoning officer.
 - (b) **Interior Lot.** For an interior lot with only one street frontage, that street right-of-way frontage is the front lot line, irrespective of the street's designation as an A, B, or C street.

(c) Corner Lots.

- [1] On corner lots at the intersection of an A and B street, the A-street frontage is the front lot line.
- [2] On corner lots at the intersection of a B and C street, the B-street frontage is the front lot line.
- [3] On corner lots at the intersection of two A or two B street, the street with the most existing front treatments, as determined by the zoning officer, must be treated as the front of the lot. The second street frontage may be treated as a second front or as side-street frontage.

(d) C Streets. C-street frontage may be the front lot line only if no other street frontage exists.

(5) A Street Double-Frontage Lots. In all zones except I zones, where a lot extends from one A street through the block to another A street that is generally parallel to the first A street, the lot is a double-frontage lot and the following applies:

- (a)** The subject lot's frontage facing the same or most similar zone on the lot directly across the street must meet one of the building types for the subject lot's zone. See [Figure 660-13\(1\)](#).
- (b)** In MX-D, MX-C, MX-S, GX-D, and GX-C zones, the second frontage may utilize the regulations of any allowed building type and uses on the lot across the street or any building type and use allowed within the GX-C zone. If a building type not allowed on the subject lot is utilized, the regulations must be met for a minimum of 30 feet of lot depth and a maximum of half of the lot depth, measured from the second frontage.

(6) Rear Lot Lines. Rear lot lines are typically opposite of front lot lines and abut either an alley, C street, or the side or rear lot line of another lot.

(7) Side-Street Lot Line. Side street lot lines are any street frontages that are not front or rear lot lines.

(8) Side Lot Line. Side lot lines are interior to the lot, abutting another lot, and perpendicular to the front lot line.

(9) Other Frontages to be Treated with Front Facade Regulations. The following other frontages must be treated with front facade regulations per the building type, in addition to any street frontage determined by this subsection.

- (a) Waterfronts.** Buildings on lots with major waterway frontage must treat building facades facing the waterway as front facades, unless otherwise stated in this ordinance. See definition of major waterway in [660-149](#).

(b) Civic or Open Space Frontage. Buildings on lots containing or abutting P1-zoned parks, plazas, or other public open spaces must treat building facades facing that space as front facades with the exception of minimum entrance requirements.

660-12.K DRIVEWAY ACCESS

(1) Driveway Design. See [660-86.C](#) for size of driveway access.

(2) Hierarchy of Access Point Location. Unless otherwise expressly stated in the building type tables, the following applies to all building types:

(a) C Streets or Alleys. Driveway access is allowed off any C street or improved alley.

(b) Side Street. Driveway access is allowed off any side street abutting any lot.

(c) Front Street. If no C street, improved alley, or side street abuts the lot, one driveway access point per lot is allowed off the front street except as follows:

- [1] Front street access is not allowed off Hamilton Street in MX-D and GX-D.
- [2] Front street access is not allowed in the N1, N2, and N3 zones, except where front street access already exists for at least 50% of the properties on the street on the subject blockface.
- [3] Where significant topography or utility conflicts exist, as determined by the city engineer, a special exception may be requested for front street access, except on Hamilton Street in MX-D and GX-D.

660-12.L MINIMUM STREETSCAPE AREA

A minimum area between the street pavement and the lot line is required to ensure adequate pedestrian facilities are provided along all streets, including, at a minimum, sidewalks and street trees.

(1) Applicability. The following applies when the total development (one or more lots) includes at least 60 feet of total contiguous street frontage, or a development with less street frontage is located abutting vacant parcels (under similar or separate ownership), where the development plus the vacant parcels totals 100 feet of contiguous street frontage.

(a) Exceptions. The zoning officer may exempt a parcel from this requirement under the following circumstances:

- [1] **Context.** The majority of existing buildings on the remaining blockface, under separate ownership from the subject parcels, are located

such that the additional setback area for the remainder of the block is not practicable.

- [2] **Lot Width.** The developability of the lot would be significantly reduced, such as a corner lot 20 feet in width being reduced to less than 18 feet wide.
- [3] **Lot Depth.** Lots less than 80 feet in depth are exempt.
- [4] **C Streets.** Developments along C streets are exempt.

- (2) **Minimum Streetscape Area.** Where the area from the face of curb/edge of pavement to the lot line is less than 9 feet, the build-to zone/setback must be measured from 9 feet off the face of curb/edge of pavement.
- (3) **Streetscape.** The extended streetscape area must be treated with streetscape per 350-12 of the land use and subdivision regulations.
- (4) **Easement.** A public easement may be required per the zoning officer where the sidewalk would be located on private property.

660-13 Outdoor Sites

The following outdoor sites do not include a principal building. Outdoor sites are not required to conform to building type regulations except as defined in this section.

660-13.A PARKS AND OPEN SPACE SITES

Parks and open space uses per Table 660-5, including community gardens and urban agriculture, with no principal building on the site.

- (1) **Principal Buildings.** When a principal building is located on a park and open space site, such as a community recreation facility or center, the building must meet the regulations of a building type allowed in the zone.
- (2) **Accessory uses and structures are allowed per Article 5.** On park and open space sites, outbuildings and accessory structures are allowed, accessory to the principal use, such as restroom pavilions, sheds, ticket booths, and other similar structures. All accessory structures must meet the following:
 - (a) All accessory structures must be located a minimum of 30 feet from any lot line.
 - (b) The total footprint of all accessory structures on the lot may not exceed 25% of the lot.
 - (c) The maximum overall height of any accessory structure is 25 feet.

660-13.B SURFACE PARKING SITES

Sites where a surface parking lot is the principal use of the site per Table 660-5 and no permanent principal building is located on the site.

- (1) **Kiosks.** A kiosk is a small footprint structure with one or more openings used to vend tickets. Ticket kiosks are allowed on surface parking sites as accessory structures provided the following:
 - (a) The kiosk must be located a minimum of 10 feet from any lot line.
 - (b) No more than 4 kiosks may be located on any site and the total footprint of all kiosks may not exceed 400 square feet and 10% of the site.
 - (c) The maximum overall height of the kiosk may not exceed 15 feet.
- (2) No accessory structures other than a kiosk are allowed.

660-13.C INDUSTRIAL & INFRASTRUCTURE SITES

(1) **Infrastructure Sites.** All infrastructure sites per Table 660-5 are allowed without a principal building.

(2) **Industrial Sites.** Industrial sites consisting only of outdoor equipment and supply storage with no permanent principal building are allowed per Article 4.

- (a) Outdoor storage and outbuilding accessory uses and structures are allowed on this site. Other accessory uses and structures are allowed per Article 5.
- (b) All accessory structures on industrial outdoor sites must meet the following:
 - [1] All accessory structures must be located within the rear 50% of the lot, as measured from the front street lot line, and a minimum of 30 feet from any other lot line.
 - [2] The total footprint of all accessory structures on the lot may cover no more than 25% of the lot.
 - [3] The maximum overall height of any accessory structure is 25 feet.
- (c) All outdoor storage uses must meet the regulations for location and screening in 660-45.

660-13.D MANUFACTURED (MOBILE) HOME PARK AND TINY HOME VILLAGES

Any lot under single ownership that includes 3 or more manufactured/mobile homes (including tiny homes) for residential use is subject to the following:

- (1) **Where Allowed**
 - (a) Manufactured/mobile home parks are allowed as a household living use in accordance with Table

660-5. They are also subject to all applicable supplemental regulations of 660-30.A.

- (b) Tiny home villages are allowed as temporary shelters in accordance with Table 660-5. They are also subject to supplemental regulations that apply to temporary shelters (see 660-30.D).
- (2) **Lot Size.** The lot must be a minimum of 2 contiguous acres in size.
- (3) **Density.** Maximum density may not exceed 5 dwelling units per acre.
- (4) **Dwelling Unit Size.** Manufactured/mobile homes are subject to the minimum floor area requirements of Table 660-3. Tiny homes used as temporary shelters are subject to the alternative minimum floor area requirements of Table 660-4.
- (5) **Compliance.** Each newly placed manufactured/mobile home or tiny home shall comply with national Manufactured Home Construction and Safety Standards (24 CFR Part 3280).
- (6) **Anchored.** Each dwelling unit shall be securely anchored to the ground to resist damage from high winds.
- (7) **Base Enclosure.** The area from the base of each dwelling unit to the ground shall be surrounded by an enclosure that has the appearance of a foundation of a site-built home.
- (8) **Perimeter Landscape Buffer.** For any new or expanded manufactured home park or tiny home village, a landscaped area with a minimum width of 25 feet shall be maintained around the perimeter of subject site, which shall only be interrupted at approximately perpendicular vehicle or utility crossings. Such landscaped area shall not include any buildings.
- (9) **Unit Spacing & Setbacks.** Each mobile/manufactured home shall be set back a minimum of 20 feet from any other mobile/manufactured home and at least 35 feet from any exterior lot line. For twin mobile/manufactured homes, no side setback is required along the common or shared wall between abutting units.
- (10) **Pavement.** Interior roads and required parking spaces must comply with the surfacing standards of 660-86.G

660-13.E FOOD TRUCK SITES

Where food trucks are the principal use on the site, no principal building is required. The supplemental use regulations for food trucks in 660-31.F(3)(c), including but not limited to lot coverage and setbacks, apply.

660-14 Storefront Building

660-14.A DESCRIPTION AND INTENT

With a variety of available scales depending on the zone, the Storefront building type is intended for use in the downtown, along corridors, and at neighborhood nodes, accommodating shopping, services, and eating establishments in a building with uses mixed vertically. Oriented to the street with narrow or no side setbacks, this building type is highly accessible to the pedestrian. Ground story storefront glass, entrances along the sidewalk, and windows in upper stories facing the street make these buildings interesting and inviting to pedestrians. Parking, where provided, is located in the rear yard.

660-14.B ILLUSTRATIVE IMAGES

The images shown in Figure 660-14(1) are intended to illustrate the general character of the building type. The buildings and sites in each image may not fulfill all of the building type regulations.

660-14.C BUILDING REGULATIONS

The following tables and illustrations regulate this specific building type. See 660-12 for general regulations for all building types. See Article 13 for definitions and measuring table regulations.

LINK	SUBSECTION
660-14.D	Building Siting
660-14.E	Parking & Accessory Structures
660-14.F	Number & Location of Dwelling Units
660-14.G	Height
660-14.H	Roofs
660-14.I	Front & Side-Street Facades
660-14.J	Supplemental Regulations



Figure 660-14(1) Storefront Building Type Examples

Figure 660-14(2) Storefront Building Siting

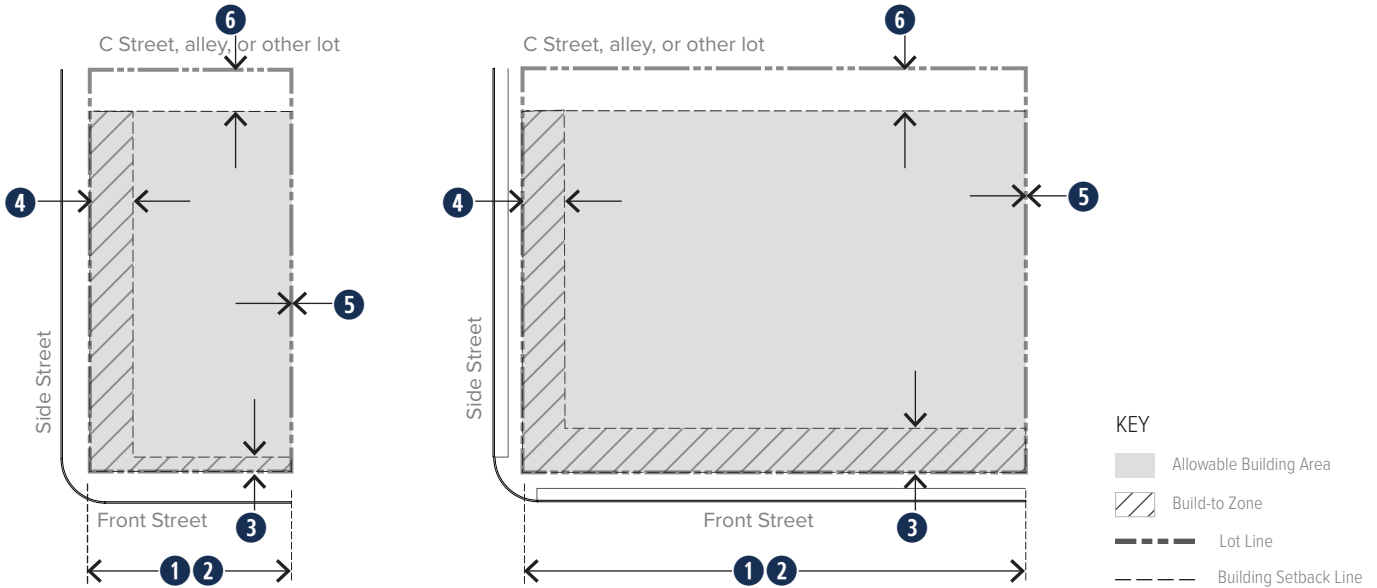

ZONES

		MX-D	MX-C	MX-N	MX-S	Additional/References
660-14.D. BUILDING SITING. See Figure 660-14(2)						
	Multiple Principal Buildings	Not allowed	Not allowed	Not allowed	Allowed; each building must meet all regulations	
1	Lot Width	18 ft. min.	18 ft. min.	18 ft. min. 50 ft. max.	50 ft. min.	
	Lot Frontage	A or B street. See 660-12.J for front street designation regulations.				
2	Front Streetwall	90% min.	75% min.	75% min.	65% min.	See 660-126.F for measuring.
		See front streetwall allowances for courtyard or plaza per 660-14.J(1)				
3	Front Build-to Zone	0 min. 5 ft. max.	0 min. 10 ft. max.	0 min. 20 ft. max.	5 ft. min. 15 ft. max.	Minimum streetscape area required per 660-12.L .
4	Side-Street Build-to Zone	0 min. 15 ft. max.	0 min. 15 ft. max.	0 min. 15 ft. max.	0 min. 15 ft. max.	Double-frontage lots addressed per 660-12.J(5) .
5	Side Setback	0 min.	0 min.	0 min.	0 min.	See 660-126.G for measuring.
		If any side setback is provided, at least 5 ft. is required.				
6	Rear Setback	0 min.	0 min. at improved alley or C street;	20 ft. min. abutting another lot		See 660-73 for required rear and side buffers.
7	Building Coverage	no limit	no limit	no limit	70% max.	See 660-126.I for measuring building coverage.

Figure 660-14(3) Storefront Building Parking Siting

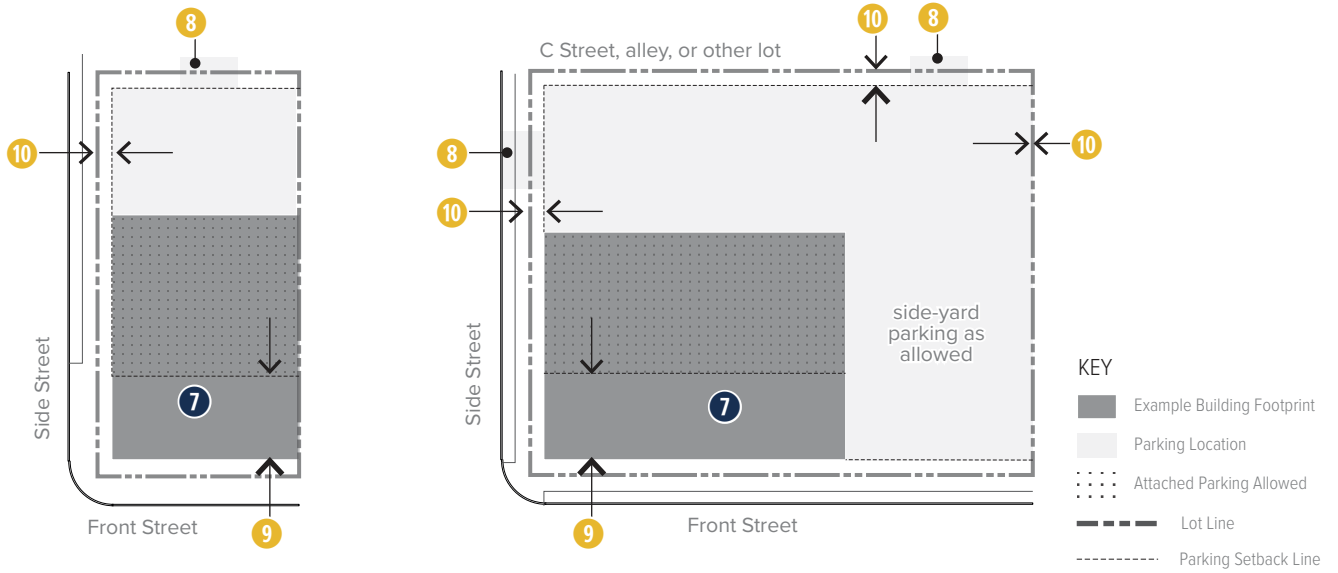

ZONES

	MX-D	MX-C	MX-N	MX-S	Additional/References	
660-14.E. PARKING & ACCESSORY STRUCTURES. See Figure 660-14(3).						
8	Parking & Driveway Access	Driveway access is allowed per 660-12.K.		One driveway access is allowed per 120 ft. of any street frontage	See Article 8 for parking. See 660-12.I for loading.	
9	Garage Setback within Building Vehicular Door Location	20 ft. min. behind front facade above any basement Rear facade only; if the rear facade is not practicable, the side-street facade may be approved, except along Hamilton Street in MX-D.				
10	Surface Parking Location	Rear yard	Rear yard	Rear yard	Rear, side yard	See 660-126.K for allowed limited side-yard parking layout. See 660-72 for frontage buffer on C streets.
	Front & Side-Street Setback	No closer to lot line than principal building				
	Side & Rear Setback	3 ft. min.; 0 min. at improved alley		3 ft. min.		
11	Accessory Structure Location	Rear yard	Rear yard	Rear yard	Rear yard	See Article 5 for accessory structures.
	Side-Street Setback	No closer to lot line than principal building				
	Side & Rear Setback	5 ft. min.	5 ft. min.	5 ft. min.	5 ft. min.	
KEY ACCESSORY STRUCTURES						
	Outbuildings	●	●	●	●	See Article 5 for accessory structures and uses. KEY: ● = Allowed ○ = Requires Special Exception - = Not Allowed
	Drive-Through Facilities	-	-	-	●	
	Fuel Pumps	-	-	-	●	
	Outdoor Storage	-	-	-	○	
	Parking Structure	●	●	-	●	
660-14.F. NUMBER & LOCATION OF DWELLING UNITS						
	Principal Dwelling Units	unlimited	unlimited	up to 6 units	unlimited	See Article 4 for allowed uses.
	Accessory Dwelling Units	-	-	-	-	

Figure 660-14(4) Storefront Building Height and Roofs

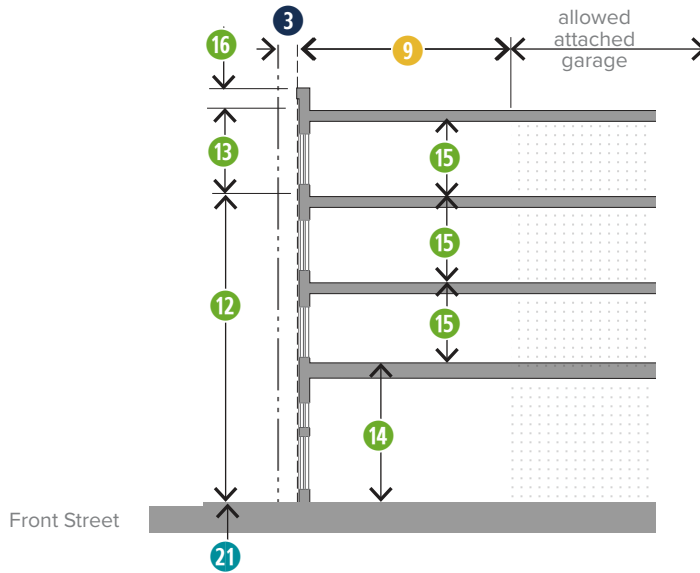

		ZONES				
		MX-D	MX-C	MX-N	MX-S	Additional/References
660-14.G. HEIGHT. See Figure 660-14(4)						
12	Height	minimum maximum	3 stories 14 stories	2 stories 3 stories	2 stories 3 stories	
13	Additional Stories for Affordable Housing on Mixed-Use Corridors	–	+2 stories per 660-14.J(2)	–	+2 stories per 660-14.J(2)	Mixed-Use Corridors defined in 660-139.
	Additional Stories for Affordable Housing in Other Locations	–	+2 stories with special exception approval per 660-14.J(2)	–	+2 stories with special exception approval per 660-14.J(2)	See 660-14.J(4) for required setbacks at N zones.
	Additional Height Allowed in High-Rise by Floor-Area Ratio	See 660-14.J(3).	–	–	–	See standards for high-rises in 660-61.
14	Ground Story Height	12 ft. min. 18 ft. max.	10 ft. min. 15 ft. max.	10 ft. min. 15 ft. max. 9 ft. min. with min. 18" stoop	12 ft. min. 14 ft. max.	Measured floor-to-floor. See 660-126.M for measuring height and allowances for taller spaces.
15	Upper Story Height	9 ft. min. 14 ft. max.	9 ft. min. 11 ft. max.	9 ft. min. 11 ft. max.	9 ft. min. 14 ft. max.	
660-14.H. ROOFS. See Figure 660-14(4)						
16	Allowed Roof Types	Flat, Parapet	Flat, Parapet, Pitched	Flat, Parapet, Pitched	Flat, Parapet, Pitched	See 660-55 for roof types and towers
	Tower	Allowed	Allowed	Allowed	Allowed	

Figure 660-14(5) Storefront Building Facades

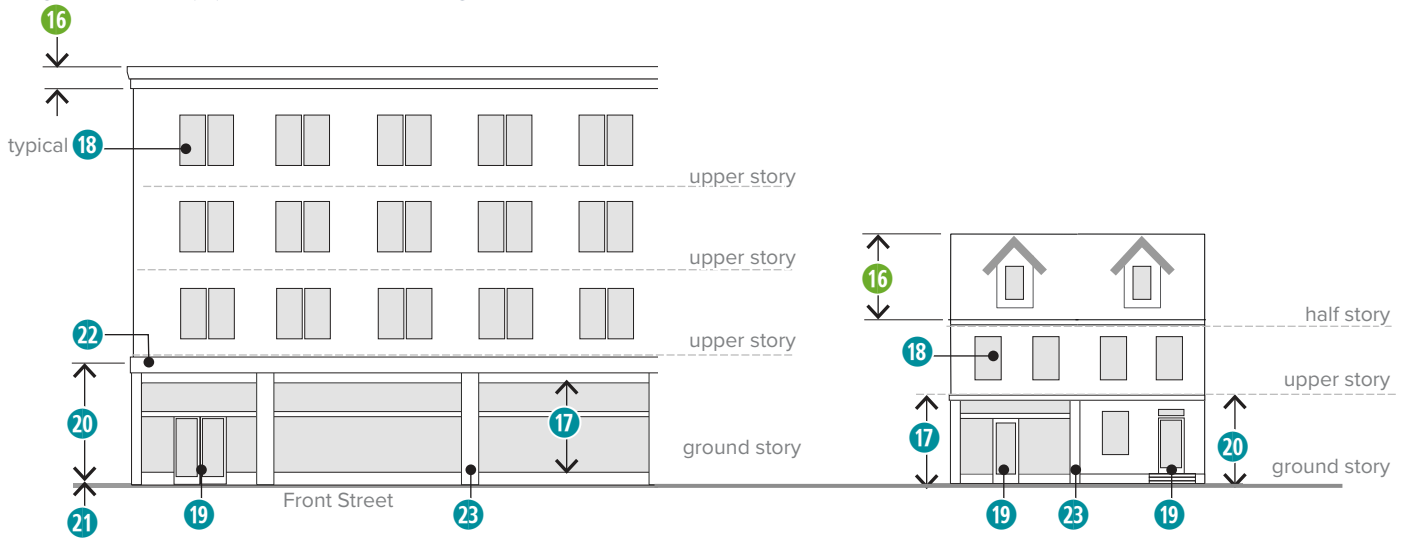

ZONES

		MX-D	MX-C	MX-N	MX-S	Additional/References
660-14.I. FRONT & SIDE-STREET FACADES. See Figure 660-14(5)						
17	Ground Story Transparency on Front Facades	70% min.	60% min., except 15% for existing residential building fronting on N 7th Street	45% min.	70% min.	See 660-126.N for measuring transparency. Measured per story, includes any half stories, visible basement, or towers with full height stories.
		Measured between 2 ft. and 9 ft. from sidewalk grade				
		No bay nor 15-ft.-wide section of any story may be without transparency				
		Ground story transparency must extend min. 30 ft. around the corner down any side-street facades				
18	Transparency: Front & Side-Street Facades	20% min.	15% min.	15% min.	20% min.	
		No bay nor 15-ft.-wide section of any story may be without transparency				
19	Building Entrances	One principal entrance per every 45 feet of front facade				See 660-126.O for measuring building entrance location.
20	Allowed Entrance Types	Storefront	Storefront, Stoop	Storefront, Stoop	Storefront	See 660-57 for entrance types.
21	Ground-Floor Elevation	Within 30 in. of sidewalk elevation				
22	Horizontal Divisions with Shadow Lines	Within 3 ft. of the top of ground story	Within 3 ft. of the top of any story between the basement and 3rd story			Horizontal shadow lines to run a min. 80% of length of facade.
23	Vertical Divisions with Shadow Lines	One per every 45 ft. of ground story front facade	One per every 30 ft. of ground story front facade			See 660-145 for definition of shadow lines.

660-14.J SUPPLEMENTAL STOREFRONT BUILDING REGULATIONS

- (1) Front Streetwall Variation.** Either a courtyard or an outdoor seating/dining area may count towards the streetwall requirement, provided the following regulations are met:
- (a) Courtyard.** The courtyard must have a minimum of 30 feet in width and a minimum of 20 feet in depth, surrounded on 3 sides by occupied building facade.
 - [1] The courtyard may count towards front streetwall when abutting the build-to zone.
 - [2] One side of the courtyard may be defined by a landscape wall constructed of an allowed facade material.
 - [3] Parking is not allowed in courtyards.
 - [4] Courtyard facades must be treated as front facades per facade regulations for the building type and any design regulations in [Article 6](#).
 - [5] The courtyard must include special paving materials and patterns, and landscape materials such as trees in grates or planters and/or landscape beds.
 - [6] Temporary or permanent seating is required. Temporary seating must be available or in place between May 15 and September 15.
 - (b) Outdoor Seating or Dining Plaza.** A front or side-street build-to zone may be expanded up to 20 feet from the lot line for a maximum of 20% of the front street facade or 100% of the side-street facade to allow for a permanent outdoor seating plaza or outdoor dining area. For example, a build-to zone of between 0 and 5 feet could be expanded to 0 and 25 feet.
 - [1] The seating/dining areas must be included in the street yard landscape per [350-12](#). Special paving materials and patterns, landscape

materials such as trees in grates or planters and/or landscape beds must be included.

- [2] Temporary or permanent seating is required. Temporary seating must be available or in place between May 15 and September 15.

(2) Additional Stories For Affordable Housing. Where additional stories are allowed for affordable housing per [660-14.G](#), the following applies:

- (a) Affordable Housing.** The project must meet the definition of affordable housing per [660-30.A\(3\)\(c\)](#) and any supplemental use regulations associated with affordable housing.
- (b) Mixed-Use Corridors.** Except within a historic district, buildings on lots abutting one of the Mixed-Use Corridors (per [660-139](#)) may include up to 2 additional stories for affordable housing on top of the allowed 3 stories for a total of up to 5 stories. See [660-14.J\(4\)](#) for required setback at N zones.
- (c) Other Locations.** Except within a historic district, buildings on lots that do not abut one of the Mixed-Use Corridors (per [660-139](#)) may request special exception approval to include up to 2 additional stories for affordable housing on top of the allowed height of 3 stories for a total of up to 5 stories. See [660-14.J\(4\)](#) for required setback at N zones.

(3) Floor Area Ratio (FAR) in Downtown Zone. In MX-D, additional height is allowed in high-rise stories above the base story height as follows:

- (a)** On lots less than 80 feet in width, no additional floor area is allowed above the base height.
- (b)** On lots 80 feet or more in width, heights may be increased up to a total allowed floor-area-ratio for the building of no more than 24.
- (c)** See [660-61](#) for high-rise design standards.

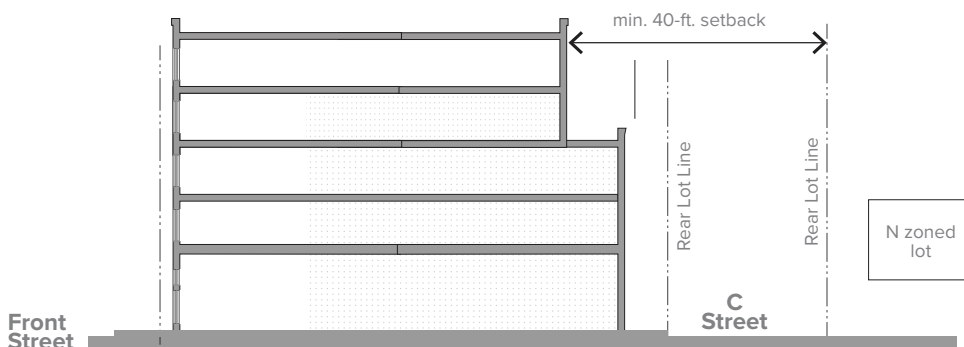

Figure 660-14(6) Required Setback Additional Height along Mixed-Use Corridors across from N Zone

(4) Setback at N Zones. Any allowed "additional story" per 660-14.J(2) must be set back in the rear or side from any adjacent N-zoned lot line a minimum of 40 feet, including any C street or improved alley within the setback area. For example, if the C street between the subject lot and adjacent N-zoned lot is 25 feet in width and the building is setback from the C street 15 feet, no additional story setback is required. See Figure 660-14(6).

[page intentionally blank]

660-15 Commercial Center

660-15.A DESCRIPTION AND INTENT

The Commercial Center is a single building or collection of buildings accommodating both vehicular and pedestrian access comfortably. Some buildings must be built up to the sidewalk; however, additional buildings may be located set back from the front lot line. Vehicular uses, such as fueling stations and service stations, may be located within this building type, along with shopping centers and larger grocery stores.

660-15.B ILLUSTRATIVE IMAGES

The images shown in Figure 660-15(1) are intended to illustrate the general character of the building type. The buildings and sites in each image may not fulfill all of the building type regulations.

660-15.C BUILDING REGULATIONS

The following tables and illustrations regulate this specific building type. See 660-12 for general regulations for all building types. See Article 13 for definitions and measuring table regulations.

LINK	SUBSECTION
660-15.D	Building Siting
660-15.E	Parking & Accessory Structures
660-15.F	Number & Location of Dwelling Units
660-15.G	Height
660-15.H	Roofs
660-15.I	Front & Side-Street Facades
660-15.J	Supplemental Regulations



Figure 660-15(1) Commercial Center Building Type Examples

Figure 660-15(2) Commercial Center Building Siting

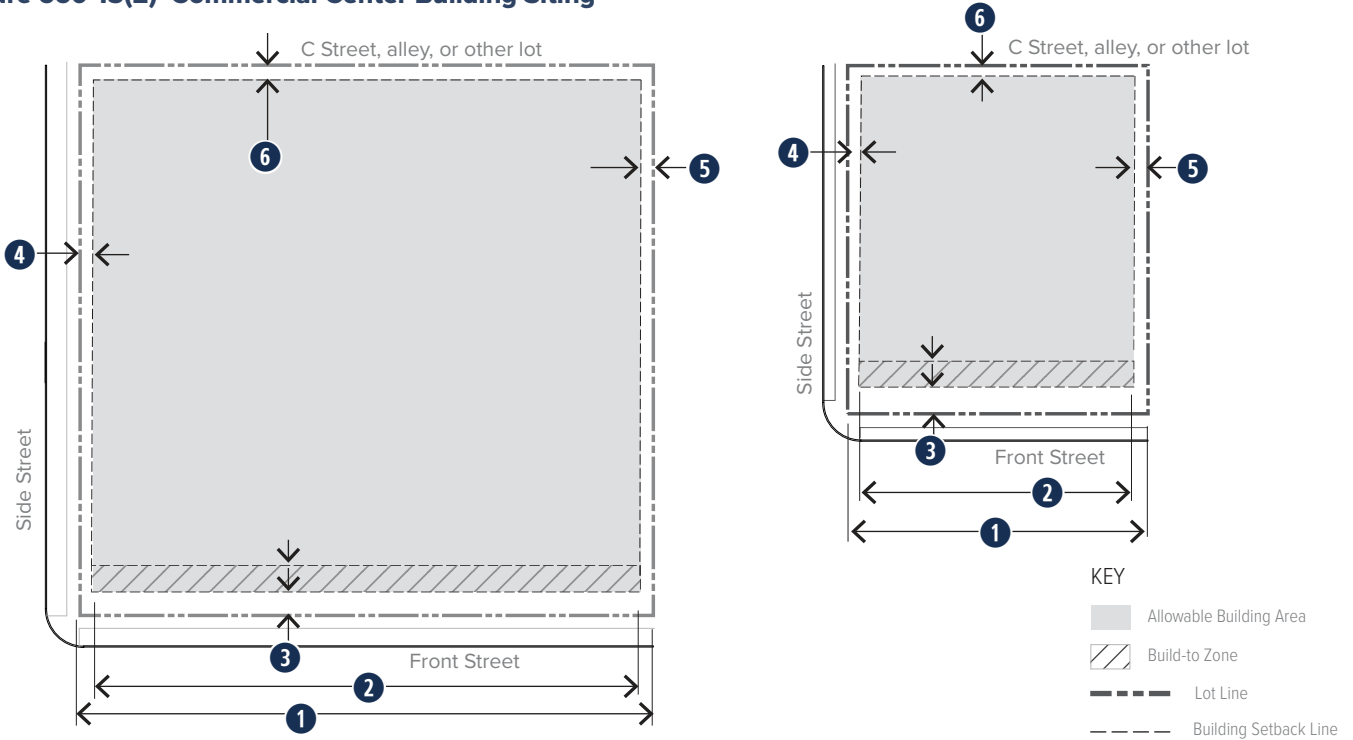

ZONES

MX-S

Additional/References

660-15.D. BUILDING SITING. See Figure 660-15(2).		
	Multiple Principal Buildings	Allowed; all buildings must meet all regulations.
1	Lot Width	60 ft. min.
	Lot Frontage	A or B street. See 660-12.J for front street designation regulations.
2	Front Streetwall	65% min.; see 660-15.J for locations where reduced minimum streetwall is allowed
3	Front Build-to Zone	10 ft. min. 20 ft. max.
4	Side-Street Setback	5 ft. min.
5	Side Setback	5 ft. min., 10 ft. abutting any N zone
6	Rear Setback	5 ft. min.; 20 ft. min. abutting N zone
7	Building Coverage	60% max.

Courtyards, outdoor dining, side parking allowances per 660-15.J. Measured in build-to zone along any street frontage.

Minimum streetscape area required per 660-12.L.

See 660-126.G for measuring.

See 660-73 for required rear and side buffers.

See 660-126.I for measuring building coverage.

Figure 660-15(3) Commercial Center Parking Siting

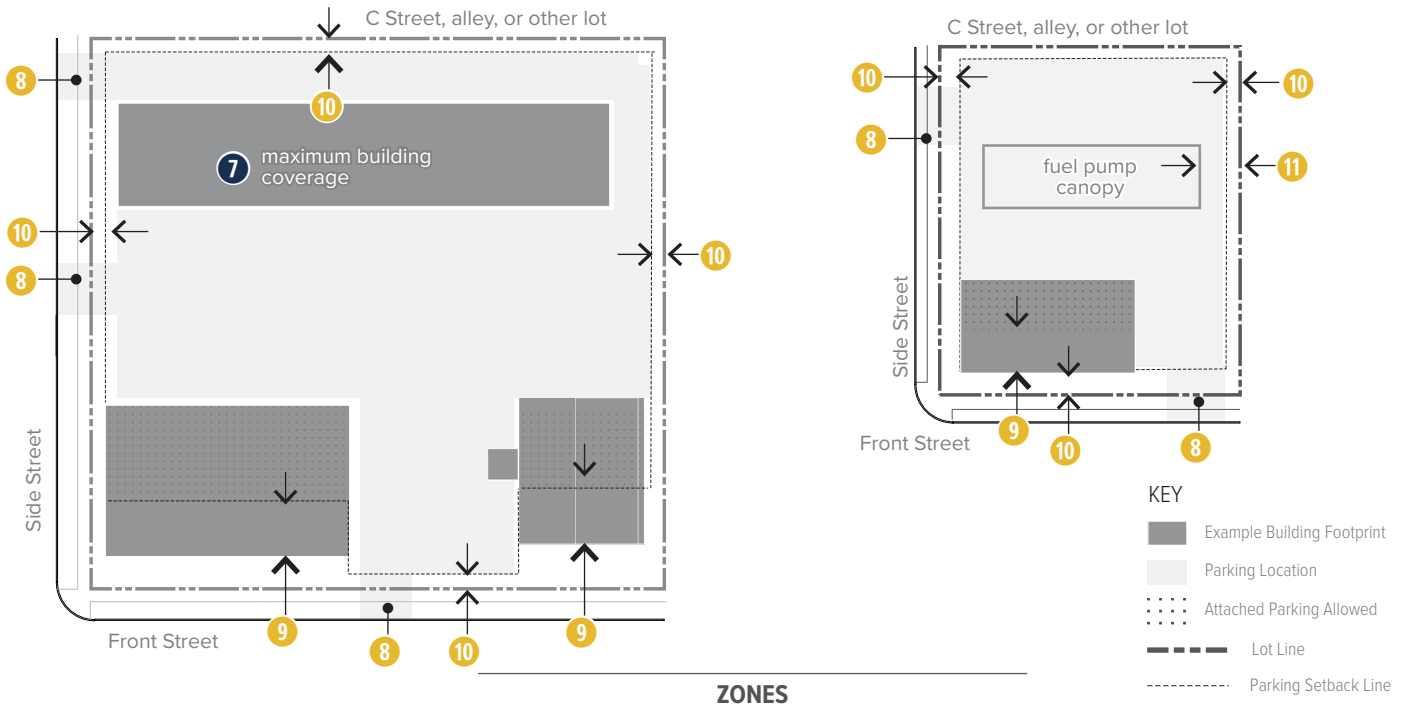

ZONES

MX-S

Additional/References

660-15.E. PARKING & ACCESSORY STRUCTURES. See Figure 660-15(3).			Additional/References
8	Parking & Driveway Access	One per 120 ft. of street frontage	See Article 8 for parking.
9	Garage Setback within Building Vehicular Door Location	20 ft. min. behind front facade above any basement Side-street, side, rear facade	
10	Surface Parking Location	Rear yard, interior yard, side yard	See 660-151 for definition of yards.
	Front & Side-Street Setback	5 ft. min.; side yard parking may extend into the front yard to within up to 5 ft. from front lot line	
	Side & Rear Setback	5 ft. min.	
11	Accessory Structure Location	Rear yard	See Article 5 for accessory structures.
	Side-Street Setback	No closer to lot line than principal building	
	Side & Rear Setback	5 ft. min.; 15 ft. min. abutting to N zone	
KEY ACCESSORY STRUCTURES			
	Outbuildings	●	KEY: ● = Allowed ○ = Requires Special Exception -- = Not Allowed
	Drive-Through Facilities	●	
	Fuel Pumps	● allowed in rear or side yard	
	Outdoor Storage	○	
	Parking Structure	●	
660-15.F. NUMBER & LOCATION OF DWELLING UNITS			
	Principal Dwelling Units	unlimited	See Article 4 for allowed uses.
	Accessory Dwelling Units	-	

Figure 660-15(4) Commercial Center Height and Roofs

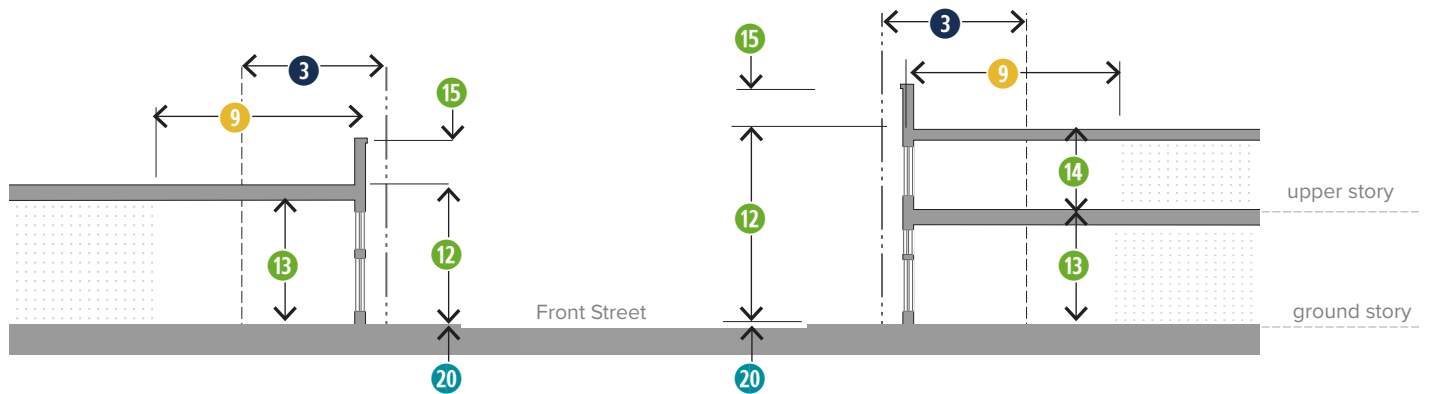

ZONES

MX-S

Additional/References

660-15.G. HEIGHT. See [Figure 660-15\(4\)](#).

12	Height	1 story min. 3 stories max.	See 660-15.J for additional height for large format spaces. Stories are measured floor-to-floor.
13	Ground Story Height	10 ft. min. 15 ft. max.; additional height for large format spaces per 660-15.J	See 660-126.M for measuring height and allowances for taller spaces.
		14 ft. min., 18 ft. max. for single-story building	
14	Upper Story Height	9 ft. min. 12 ft. max.	

660-15.H. ROOFS. See [Figure 660-15\(4\)](#).

15	Allowed Roof Types	Flat, Parapet, Pitched	See 660-55 for roof types and towers. See 660-15.J for pitched roof on single-story building.
	Tower	Allowed	

Figure 660-15(5) Commercial Center Facades

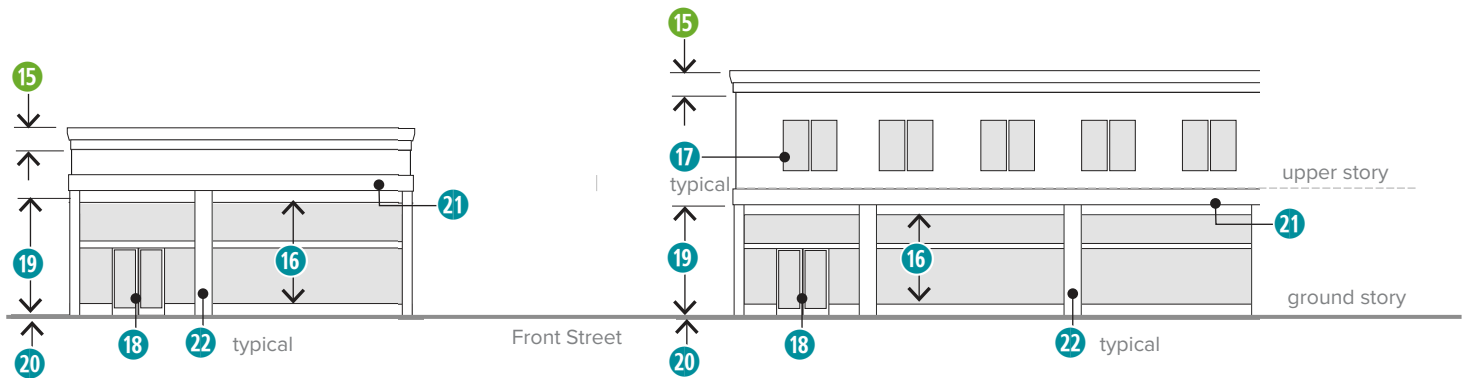

ZONES

MX-S

Additional/References

660-15.I. FRONT & SIDE-STREET FACADES. See Figure 660-15(5).

16	Ground Story Transparency on Front Facades	65% min.	Ground story transparency measured between 2 ft. and 10 ft. from sidewalk grade. See 660-126.N for measuring transparency.
		No bay nor 15-ft.-wide section of any story may be without transparency	
		Ground story transparency must extend a min. 30 ft. around the corner, down any side-street facades	
17	Transparency: Street Facades	18% min.	Measured per story, includes any half stories, visible basement, or towers with full-floor height. See 660-126.N for measuring transparency.
		No bay nor 15-ft.-wide section of any story may be without transparency	
18	Building Entrance Location	One per every 65 feet of front facade and interior-yard parking lot front-facing facades	See 660-126.O for measuring building entrance location.
19	Allowed Entrance Types	Storefront	See 660-57 for entrance types.
20	Ground-Floor Elevation	Within 24 in. of sidewalk elevation	
21	Horizontal Divisions with Shadow Lines	Within 3 ft. of the top of ground story	Horizontal shadow lines to run a min. 80% of length of facade. See 660-145 for definition of shadow lines.
22	Vertical Divisions with Shadow Lines	One per every 65 ft. of ground story front street facade	

660-15.J SUPPLEMENTAL COMMERCIAL CENTER REGULATIONS

(1) Front Streetwall Variation. Either a courtyard or an outdoor seating/dining area may count towards the streetwall requirement, provided the following regulations are met:

(a) Courtyard. The courtyard must have a minimum of 30 feet in width and a minimum of 20 feet in depth, surrounded on 3 sides by occupied building facade.

- [1] The courtyard may count towards front streetwall when abutting the build-to zone.
- [2] One side of the courtyard may be defined by a landscape wall.
- [3] Parking is not allowed in courtyards.
- [4] Courtyard facades must be treated as front facades per facade regulations for the building type and any design regulations in Article 6.
- [5] The courtyard must include special paving materials and patterns, and landscape materials such as trees in grates or planters and/or landscape beds.
- [6] Temporary or permanent seating is required. Temporary seating must be available or in place between May 15 and September 15.

(b) Outdoor Seating or Dining Plaza. A front or side-street build-to zone may be expanded up to 20 feet from the lot line for a maximum of 20% of the front street facade or 100% of the side-street facade to allow for a permanent outdoor seating plaza or outdoor dining area. For example, a build-to zone of between 0 and 5 feet could be expanded to 0 and 25 feet.

- [1] The seating/dining areas must be included in the street yard landscape per 350-12. Special paving materials and patterns, landscape materials such as trees in grates or planters and/or landscape beds must be included.
- [2] Temporary or permanent seating is required. Temporary seating must be available or in place between May 15 and September 15.

(2) Reduced Front Streetwall. The minimum streetwall may be reduced under the following circumstances:

(a) Street Frontages. Where the front lot line is parallel to one of the following streets outside of the

traditional city center, a minimum streetwall of 35% is allowed:

- [1] Union Boulevard, west of Jasper Street,
- [2] Airport Road,
- [3] Hamilton Boulevard west of College Drive,
- [4] Tilghman Street west of Cedar Crest Boulevard,
- [5] S 4th Street,
- [6] Lehigh Street south of W Tioga Street,
- [7] Glenwood Street SW,
- [8] W Emaus Avenue,
- [9] Industrial Avenue, and
- [10] 31st Street SW.

(b) Fueling Stations. Where fueling stations are located outside the street frontages defined in (a) of this subparagraph (2), a minimum streetwall of 35% is allowed.

(3) Large-Format Spaces. Large-format spaces have taller floor-to-floor heights, large building footprints, and few or no windows. Examples include such stores as grocery stores, department stores, warehouse retail stores, and movie theaters. Large-format spaces are allowed in a Commercial Center per the following:

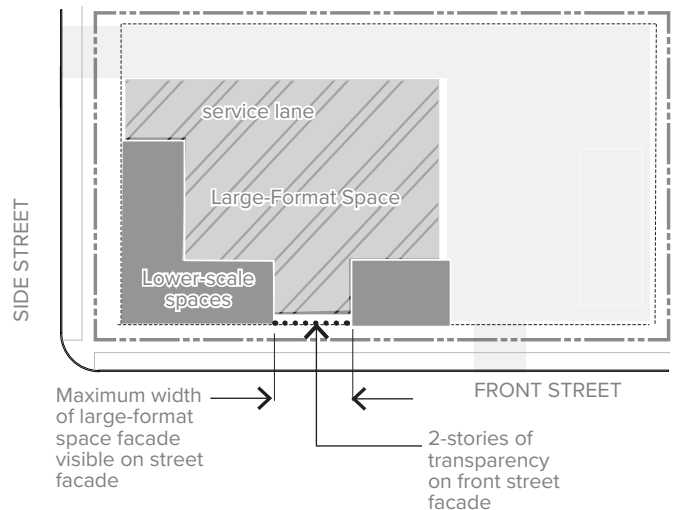

Figure 660-15(6) Large-Format Space

- (a) A ground story up to 30 feet in height is allowed for the large format space.
 - (b) The facade of the large format space is limited to a maximum horizontal distance along any front street of 60 feet. See [Figure 660-15\(6\)](#).
 - (c) Lower scaled commercial spaces meeting the building type requirements may front the large-format space to achieve the maximum frontage and number of entrances required along the frontage.
 - (d) Any heights over 18 feet located on the front facade or side-street facade must apply transparency regulations as if the building is 2 stories along those facades.
- (4) Pitched Roof on Single-Story Building.** A pitched roof on a single-story building must have a minimum pitch of 1:5. Where the ridge is parallel to a street, dormer windows must be provided, one, minimum 6 feet wide, for every 30 feet of roof length. See [Figure 660-15\(7\)](#).

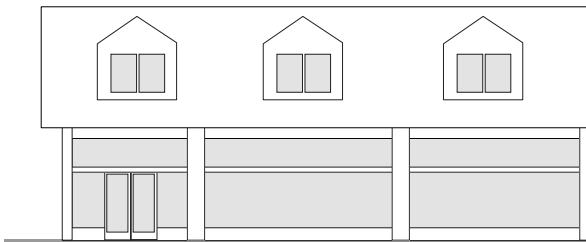

Figure 660-15(7) Pitched Roof on Single Story Commercial Center

[page intentionally blank]

660-16 General Building

660-16.A DESCRIPTION AND INTENT

The General Building is an urban building, typically housing multiple residential units, offices, laboratory spaces, classrooms, and similar spaces. Oriented to the street with an entrance to the public sidewalk, the building outside of downtown is surrounded by small yards. Parking is located in the rear yard with attached garages entered from the rear of the building. Buildings vary in length and height depending on the zone.

660-16.B ILLUSTRATIVE IMAGES

The images shown in Figure 660-16(1) are intended to illustrate the general character of the building type. The buildings and sites in each image may not fulfill all of the building type regulations.

660-16.C BUILDING REGULATIONS

The following tables and illustrations regulate this specific building type. See 660-12 for general regulations for all building types. See Article 13 for definitions and measuring table regulations.

LINK	SUBSECTION
660-16.D	Building Siting
660-16.E	Parking & Accessory Structures
660-16.F	Number & Location of Dwelling Units
660-16.G	Height
660-16.H	Roofs
660-16.I	Front & Side-Street Facades
660-16.J	Supplemental Regulations



Figure 660-16(1) General Building Type Examples

Figure 660-16(2) General Building Siting

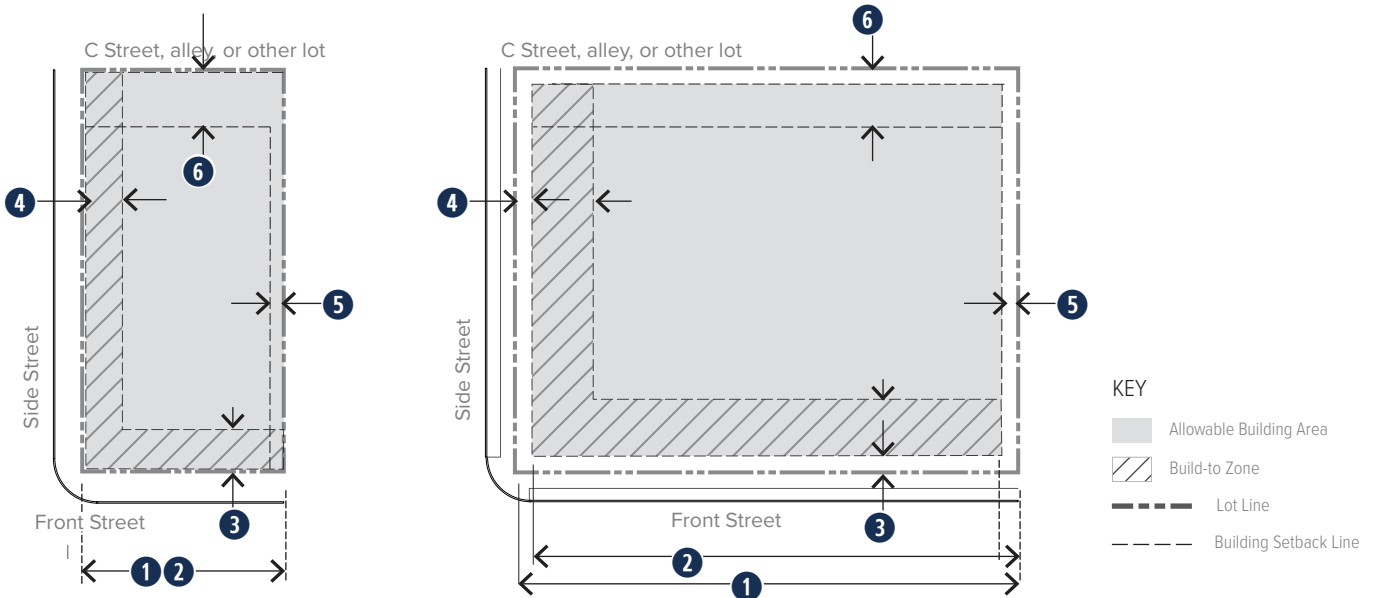

		ZONES			
		GX-D	GX-C, NX, P2	IX, IG, IM	Additional/ References
660-16.D. BUILDING SITING. See Figure 660-16(2)					
	Multiple Principal Buildings	Not allowed	Allowed; each building must meet all regulations	Allowed	
1	Lot Width	45 ft. min.	30 ft. min.	IX: 40 ft. min. IG, IM: 80 ft. min.	
	Lot Frontage	A or B street. See 660-12.J for front street designation regulations.			
2	Front Streetwall	90% min.	80% min.	80% min.	See front streetwall allowances for courtyard or plaza per 660-16.J.1.
3	Front Build-to Zone	0 ft. min. 15 ft. max.	5 ft. min. 25 ft. max.	5 ft. min. 25 ft. max.	Minimum streetscape area required per 660-12.L.
4	Side-Street Build-to Zone	0 ft. min. 15 ft. max.	5 ft. min. 25 ft. max.	5 ft. min. 25 ft. max.	
5	Side Setback	0 ft. min.; if any is provided, at least 5 ft. required	5 ft. min.	5 ft. min.	
	Space between Buildings on Lot	no min.	10 ft. min.	10 ft. min.	
6	Rear Setback	0 min.	5 ft. min. at improved alley or C street, 20 ft. min. abutting another lot	5 ft. min. at improved alley or C street, 20 ft. min. abutting another lot	See 660-16.J(4) for treatment adjacent to N zones.
7	Building Coverage	no limit	70% max.	70% max.	See 660-126.I for measuring building coverage.

Figure 660-16(3) General Building Parking Siting

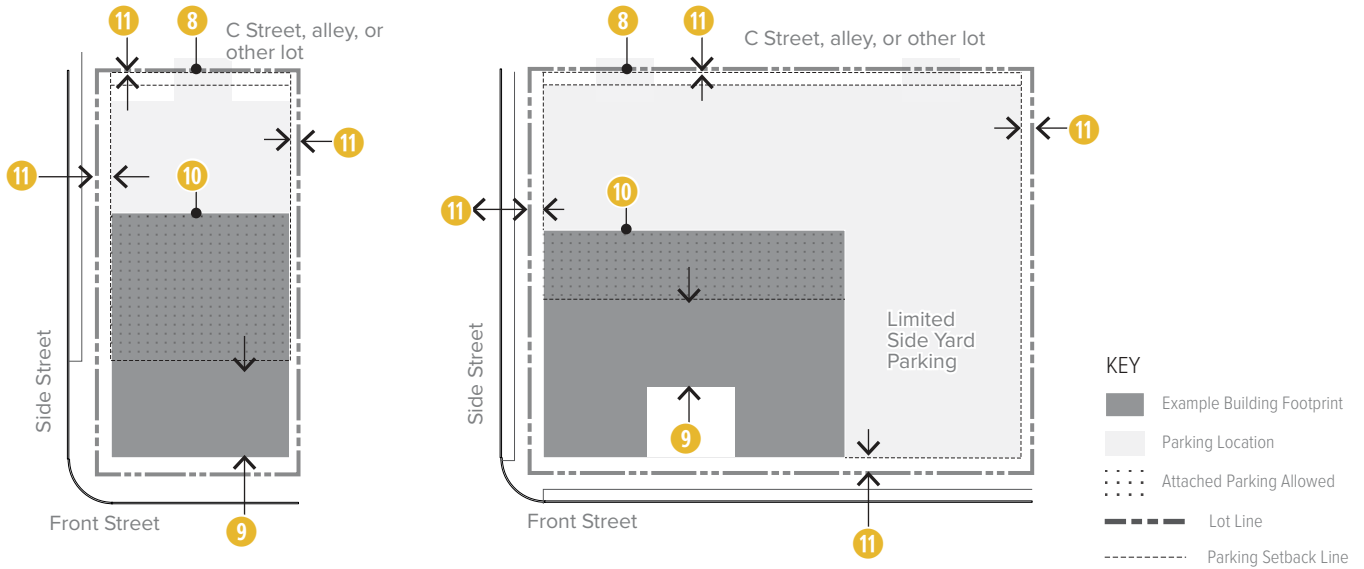

		ZONES			Additional/ References
		GX-D	GX-C, NX, P2	IX, IG, IM	
660-16.E. PARKING & ACCESSORY STRUCTURES. See Figure 660-16(3).					
8	Parking & Driveway Access	Driveway access is allowed per 660-12.K			See Article 8 for parking.
9	Garage Setback within Building	20 ft. min. behind front facade above basement			
10	Allowed Garage Door Location	Side-street, side, rear facade			
11	Surface Parking Location	Rear yard	Rear yard, limited side yard	Rear yard, side yard	See 660-126.K for allowed limited side-yard parking layout.
	Front & Side-Street Setback	No closer to lot line than principal building			
	Side & Rear Setback	3 ft. min.; 0 min. at improved alley	3 ft. min.; 0 min. at improved alley	3 ft. min.	
12	Accessory Structure Location	Rear yard	Rear yard	Rear yard	See Article 5 for accessory structures and uses.
	Side-Street Setback	No closer to lot line than principal building			
	Side & Rear Setback	5 ft. min.	5 ft. min.	5 ft. min.	
KEY ACCESSORY STRUCTURES					KEY:
	Outbuildings	●	●	●	● = Allowed
	Drive-Through Facilities	–	–	●	○ = Requires Special Exception
	Fuel Pumps	–	–	●	– = Not Allowed
	Outdoor Storage	–	–	●	
	Parking Structure	●	●	●	
660-16.F. NUMBER & LOCATION OF DWELLING UNITS					
	Principal Dwelling Units	unlimited	GX-C & NX: unlimited P2: –	–	See Article 4 for allowed uses.
	Accessory Dwelling Units	–	–	–	

Figure 660-16(4) General Building Height and Roofs

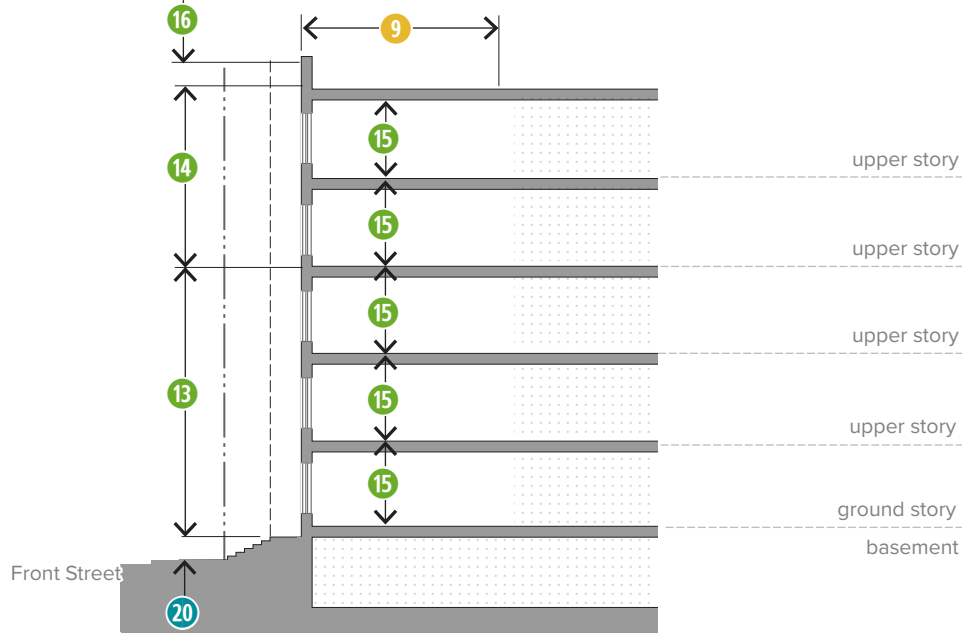

		ZONES			Additional/ References
		GX-D	GX-C, NX, P2	IX, IG, IM	
660-16.G. HEIGHT. See Figure 660-16(4)					
13	Height	3 stories min. 14 stories max.	2 stories min. 4.5 stories max.	no min. 5.5 stories max.	See 660-126.M for measuring height and allowances for taller spaces. See 660-139 for definition of Mixed-Use Corridors. See 660-16.J(4) for required setbacks at N zones. See standards for high-rises in 660-61 .
14	Additional Stories for Affordable Housing on Mixed-Use Corridors	–	+2 stories allowed per 660-16.J(2)	–	
	Additional Stories for Affordable Housing in Other Locations	–	+2 stories with special exception approval per 660-16.J(2)	–	
	Additional Height in High-Rise Allowed by Floor-Area Ratio	See 660-16.J(3)	–	–	
15	All Stories Height	10 ft. min. 18 ft. max.	10 ft. min. 16 ft. max.	10 ft. min. 18 ft. max.	Measured floor-to-floor.
660-16.H. ROOFS. See Figure 660-16(4)					
16	Allowed Roof Types	Flat, Parapet	Flat, Parapet	Flat, Parapet	See 660-55 for roof types and towers.
	Tower	Allowed	Allowed	Allowed	

Figure 660-16(5) General Building Facades



ZONES				Additional/ References
GX-D	GX-C, NX, P2	IX, IG, IM		

660-16.I. FRONT & SIDE-STREET FACADES. Figure 660-16(5)

	GX-D	GX-C, NX, P2	IX, IG, IM	Additional/ References
17 Transparency: Front Facades Side-Street Facades	20% min. 15% min.	20% min. 15% min.	20% min. 15% min.	Measured per story, includes any half stories, visible basements, or towers with full floor height. See 660-126.N for measuring transparency.
	No bay nor 15-ft.-wide section of any story may be without transparency			
18 Building Entrances Location	One per every 120 ft. of front facade	One per every 150 ft. of front facade	One per every 150 ft. of front facade	See 660-126.O for measuring building entrance location.
19 Allowed Entrance Types	Stoop, Storefront	Stoop, Storefront	Stoop	See 660-57 for entrance types. See 660-128 for definition of visible basement.
20 Ground-Floor Elevation	Between 0 in. and 30 in. above grade or between 30 in. and 48 in. with a visible basement			
21 Horizontal Divisions with Shadow Lines	Min. one within 3 ft. of the top of any story between the basement and 3rd story			Horizontal shadow lines to run a min. 80% of length of facade. See 660-145 for definition of shadow lines.
22 Vertical Divisions with Shadow Lines	One per every 120 ft. of street facade	One per every 120 ft. of street facade	One per every 120 ft. of street facade	

660-16.J SUPPLEMENTAL GENERAL BUILDING REGULATIONS

- (1) Front Streetwall Variation.** Either a courtyard or an outdoor seating/dining area may count towards the streetwall requirement, provided the following regulations are met:
- (a) Courtyard.** The courtyard must have a minimum of 30 feet in width and a minimum of 20 feet in depth, surrounded on 3 sides by occupied building facade.
- [1] The courtyard may count towards front streetwall when abutting the build-to zone.
 - [2] One side of the courtyard may be defined by a landscape wall.
 - [3] Parking is not allowed in courtyards.
 - [4] A U-shaped drop-off drive within the courtyard may be approved, provided the following are met:
 - [i] The courtyard can accommodate the turning radii required by the city engineer.
 - [ii] Separate pedestrian facilities are provided from the public sidewalk to the building entrance.
 - [iii] The remaining areas of the courtyard are generally landscaped. Courtyard facades must be treated as front facades per facade regulations for the building type and any design regulations in Article 6.
 - [5] The courtyard must include special paving materials and patterns, and landscape materials such as trees in grates or planters and/or landscape beds.
 - [6] Temporary or permanent seating is required. Temporary seating must be available or in place between May 15 and September 15.
- (b) Outdoor Seating or Dining Plaza.** A front or side-street build-to zone may be expanded up to 20 feet from the lot line for a maximum of 20% of the front street facade or 100% of the side-street facade to allow for a permanent outdoor seating plaza or outdoor dining area. For example, a build-to zone of between 0 and 5 feet could be expanded to 0 and 25 feet.
- [1] The seating/dining areas must be included in the street yard landscape per 350-12. Special paving materials and patterns, landscape materials such as trees in grates or planters and/or landscape beds must be included.

- [2] Temporary or permanent seating is required. Temporary seating must be available or in place between May 15 and September 15.

- (2) Additional Stories For Affordable Housing.** Where additional stories are allowed for affordable housing per 660-16.G, the following applies:
- (a) Affordable Housing.** The project must meet the definition of affordable housing per 660-30.A(3)(c) and any supplemental use regulations associated with affordable housing.
- (b) Mixed-Use Corridors.** Except within a historic district, buildings on lots abutting one of the Mixed-Use Corridors (per 660-139) may include up to 2 additional stories for affordable housing in addition to the allowed 4.5 stories for a total of up to 6.5 stories. See 660-16.J(4) for required setback at N zones.
- (c) Other Locations.** Except within a historic district, buildings on lots that do not abut one of the Mixed-Use Corridors (per 660-139) may request special exception approval to include up to 2 additional stories of affordable housing in addition to the allowed 4.5 stories for a total of up to 6.5 stories. See 660-16.J(4) for required setback at N zones.
- (3) Floor Area Ratio (FAR) in Downtown Zone.** In GX-D, additional height is allowed in high-rise stories above the base story height as follows:
- (a)** On lots less than 80 feet in width, no additional floor area is allowed above the base height.
 - (b)** On lots 80 feet or less in width, heights may be increased up to a total allowed floor-area-ratio for the building of no more than 24.
 - (c)** See 660-61 for high-rise design standards.
- (4) Setback at N Zones.** Any allowed "additional story" per 660-16.J(2) must be set back in the rear or side from any adjacent N-zoned lot line a minimum of 40 feet, including any C street or improved alley within the setback area. For example, if the C street between the subject lot and adjacent N-zoned lot is 25 feet in width and the building is setback from the C street 15 feet, no additional story setback is required. See Figure 660-14(6).

660-17 Small General Building

660-17.A DESCRIPTION AND INTENT

The Small General building is a basic urban building, typically housing multiple residential units, office, laboratory spaces, classrooms, and similar spaces. Oriented to the street with an entrance to the public sidewalk, the building often has a small front setback. The scale of the building is smaller than the General building, lower in height and limited in width. Parking is located in the rear yard.

660-17.B ILLUSTRATIVE IMAGES

The images shown in Figure 660-17(1) are intended to illustrate the general character of the building type. The buildings and sites in each image may not fulfill all of the building type regulations.

660-17.C BUILDING REGULATIONS

The following tables and illustrations regulate this specific building type. See 660-12 for general regulations for all building types. See Article 13 for definitions and measuring table regulations.

LINK	SUBSECTION
660-17.D	Building Siting
660-17.E	Parking & Accessory Structures
660-17.F	Number & Location of Dwelling Units
660-17.G	Height
660-17.H	Roofs
660-17.I	Front & Side-Street Facades
660-17.J	Supplemental Regulations



Figure 660-17(1) Small General Building Type Examples

Figure 660-17(2) Small General Building Siting

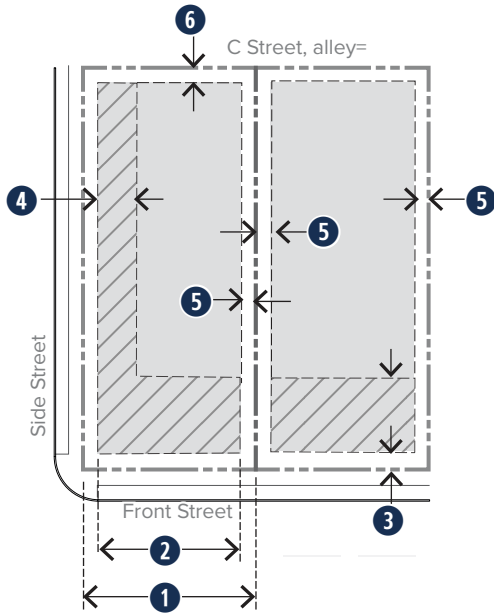

		ZONES			
		MX-N, GX-C, GX-N, NX	N1, N2	N3	Additional/ References
660-17.D. BUILDING SITING. See Figure 660-17(2)					
	Allowed per Table 660-2	Allowed	Allowed only on a street corner lot of A or B street or interior lot with special exception approval	Allowed only on a street corner lot of A or B street	
	Multiple Principal Buildings	Not allowed	Not allowed	Not allowed	
1	Lot Width	18 ft. min.	36 ft. min.	65 ft. min.	
	Lot Frontage	A or B street. See 660-12.J for front street designation regulations.			
2	Front Streetwall	65 ft. max., not including any courtyard	50 ft. max.	65 ft. max., not including any courtyard	Measured in build-to zone along any street frontage.
3	Front Build-to Zone	5 ft. min. 20 ft. max.	0 ft. min. 15 ft. max	15 ft. min. 35 ft. max	See 660-126.G for front-yard averaging. Minimum streetscape area required per 660-12.L .
4	Side-Street Build-to Zone	5 ft. min. 15 ft. max.	0 ft. min. 15 ft. max.	7.5 ft. min. 15 ft. max.	
5	Side Setback	0 ft. min; if any provided, at least 5 ft. required	0 ft. min; if any provided, at least 5 ft. required	5 ft.	
6	Rear Setback	5 ft. at improved alley or C street; 20 ft. min. abutting another lot	15 ft. min.; 0 ft. on corner lot bounded by A, B, & C streets	15 ft. min.	
7	Building Coverage	70% max.	70% max.	60% max.	See 660-126.I for measuring building coverage.

Figure 660-17(3) Small General Building Parking Siting

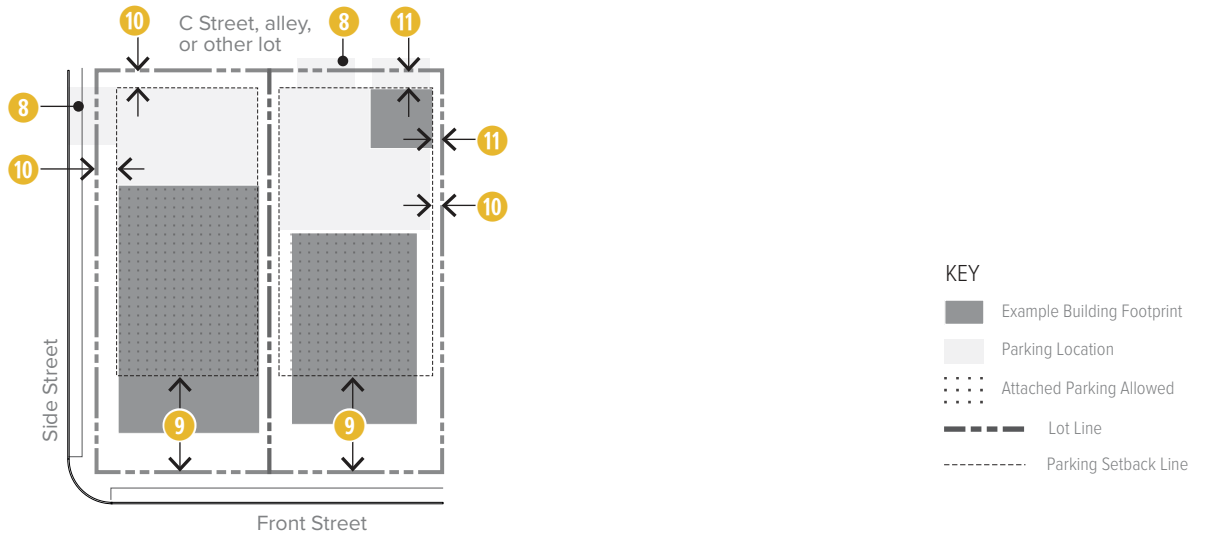

		ZONES			Additional/ References
		MX-N, GX-C, GX-N, NX	N1, N2	N3	
660-17.E. PARKING & ACCESSORY STRUCTURES. See Figure 660-17(3)					
8	Parking & Driveway Access	Driveway access is allowed per 660-12.K .			See Article 8 for parking.
9	Attached Garage Setback Allowed Garage Door Location	20 ft. min. behind front facade Side-street, rear facades			
10	Surface Parking Location	Rear yard; limited side yard	Rear yard	Rear yard	See 660-126.K for allowed limited side-yard parking layout.
	Front & Side-Street Setback	No closer to lot line than principal building			
	Side & Rear Setback	3 ft. min.; 0 min. at improved alley	3 ft. min.	3 ft. min.; 0 min. at improved alley	
11	Accessory Structure Location	Rear yard	Rear yard	Rear yard	See Article 5 accessory structures.
	Side-Street Setback	No closer to lot line than principal building			
	Side & Rear Setback	5 ft. min.	5 ft. min.	5 ft. min.	
KEY ACCESSORY STRUCTURES					
	Outbuildings (includes Detached Garages)	●	●	●	KEY: ● = Allowed ○ = Requires Special Exception -- = Not Allowed
	Drive-Through Facilities	–	–	–	
	Fuel Pumps	–	–	–	
	Outdoor Storage	–	–	–	
	Parking Structure	–	–	–	
660-17.F. NUMBER & LOCATION OF DWELLING UNITS					
	Principal Dwelling Units	Up to 3 units allowed per every 18 ft. of front building facade width; Over 12 units requires special exception approval.			See Article 4 for allowed uses.
	Accessory Dwelling Units	none	none	none	

Figure 660-17(4) Small General Building Height and Roofs

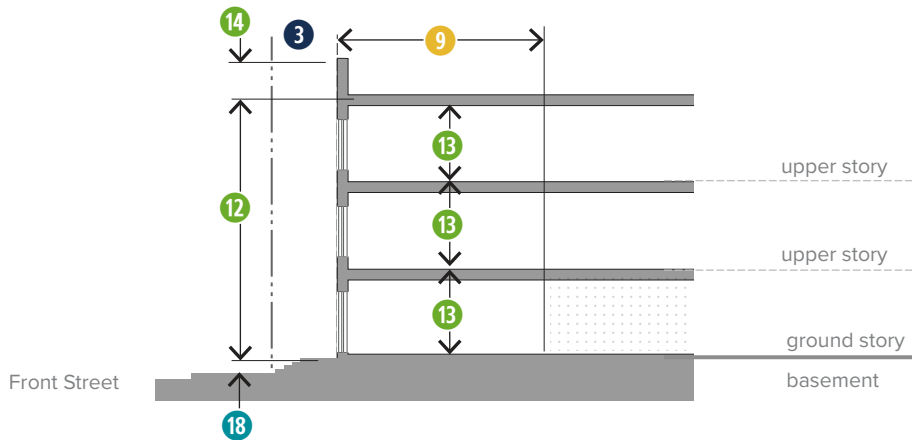

	ZONES			Additional/ References
	MX-N, GX-C, GX-N, NX	N1, N2	N3	
660-17.G. HEIGHT. See Figure 660-17(4)				
12 Height	2 stories min. 3 stories max.	2 story min. 3.5 stories max.	2 story min. 3 stories max.	See 660-126.M for measuring height.
13 Story Height	9-12 ft.	9-11 ft.	9-11 ft.	Measured floor-to-floor.
660-17.H. ROOFS. See Figure 660-17(4)				
14 Allowed Roof Types	Flat, Parapet	Flat, Parapet	Flat, Parapet, Pitched	See 660-55 for roof types and towers.
Tower	Not allowed	Not allowed	Not allowed	

Figure 660-17(5) Small General Building Facades

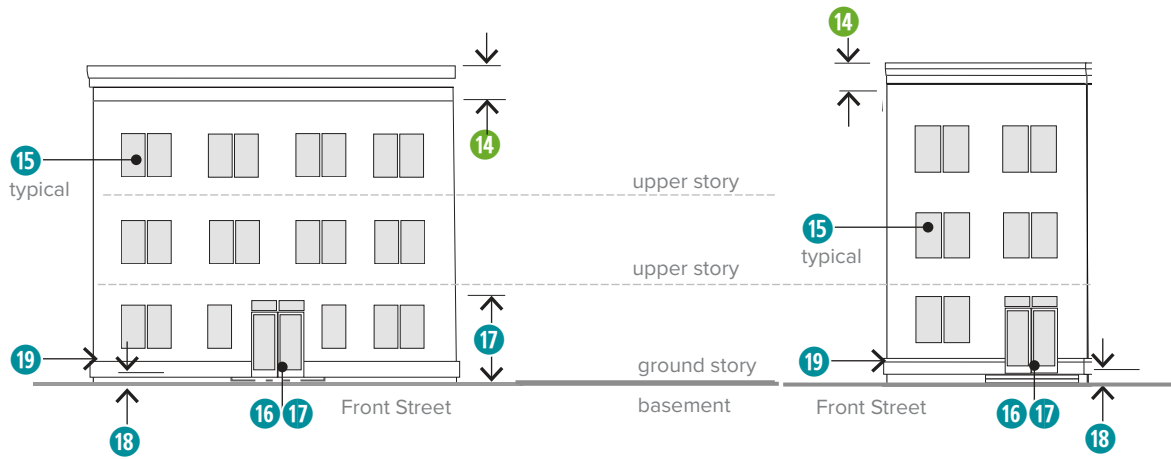

		ZONES			Additional/ References
		MX-N, GX-C, GX-N, NX	N1, N2	N3	
660-17.I. FRONT & SIDE-STREET FACADES. Figure 660-17(5)					
15	Transparency: Front and Side-Street Facades	20% min. No bay nor 10-ft.-wide section of any story may be without transparency	20% min.	20% min.	Measured per story, including any half stories, visible basement, or towers with full-floor height. See 660-126.N for measuring transparency.
16	Building Entrance Location	Front facade	Front facade	Front facade	
17	Allowed Entrance Types	Stoop	Stoop	Stoop	See 660-57 for entrance types. See 660-128 for definition of visible basement.
18	Ground-Floor Elevation	Between 0 and 30 in. above grade or between 30 in. and 48 in, with a visible basement			
19	Horizontal Divisions with Shadow Lines	Minimum of one within 3 ft. of the top of any story between the basement and 1st story			Horizontal shadow lines to run a min. 80% of length of facade. See 660-145 for definition of shadow lines.
	Vertical Divisions with Shadow Lines	-	-	-	

Article 3 Building Types
660-17 Small General Building

DRAFT

**660-17.J SUPPLEMENTAL SMALL GENERAL
BUILDING REGULATIONS**
(1) [reserved]

660-18 Town Rowhouse

660-18.A DESCRIPTION AND INTENT

Town Rowhouses are vertical units that may share side walls with one or two other units on separate abutting lots. Each unit is oriented to an A or B street, with an entrance usually from a porch accessed directly off the front sidewalk. Parking is typically located in the rear yard or in an accessory garage structure. Roofs vary in type with a half story often located within the roof structure.

660-18.B ILLUSTRATIVE IMAGES

The images shown in [Figure 660-18\(1\)](#) are intended to illustrate the general character of the building type. The buildings and sites in each image may not fulfill all of the building type regulations.

660-18.C BUILDING REGULATIONS

The following tables and illustrations regulate this specific building type and apply to each rowhouse. See [660-12](#) for general regulations for all building types. See [Article 13](#) for definitions and measuring table regulations.

LINK	SUBSECTION
660-18.D	Building Siting
660-18.E	Parking & Accessory Structures
660-18.F	Number & Location of Dwelling Units
660-18.G	Height
660-18.H	Roofs
660-18.I	Front & Side-Street Facades
660-18.J	Supplemental Regulations



Figure 660-18(1) Town Rowhouse Building Type Examples

Figure 660-18(2) Town Rowhouse Siting

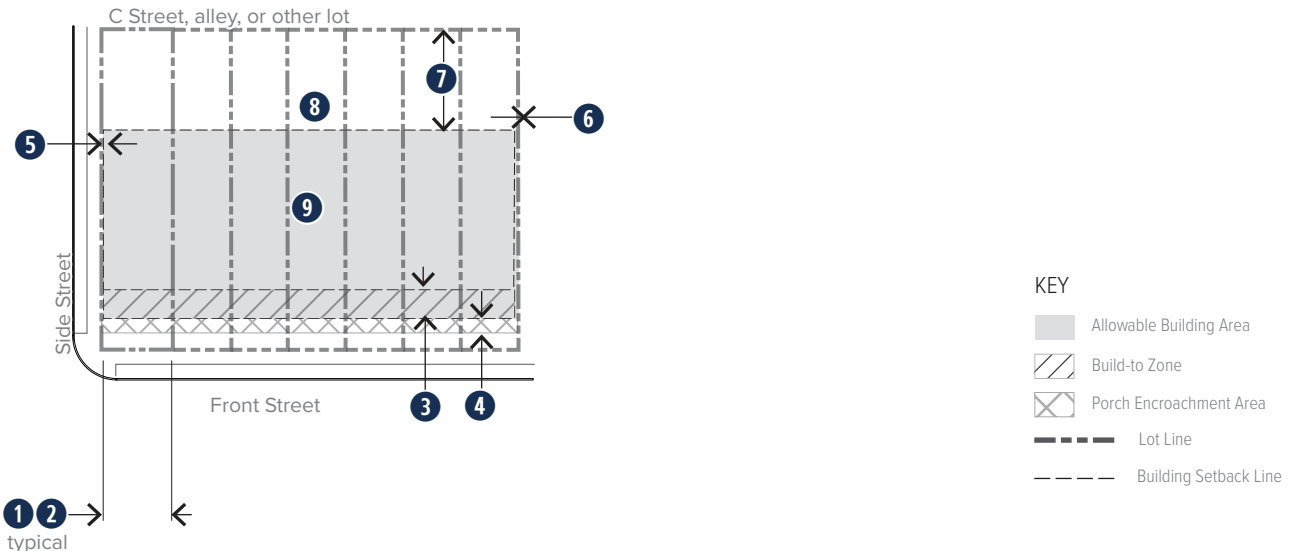

ZONES

		GX-C	GX-N, N2	Additional/References
660-18.D. BUILDING SITING. See Figure 660-18(2)				
Multiple Principal Rowhouses		Allowed	Not allowed	See 660-18.J(2) for multiple buildings on a lot.
1	Lot Width: Interior Rowhouse	18 ft.	15 ft. min.	
	End Rowhouse	20 ft.	18 ft. min.	
Lot Size		1,500 s.f. min.	1,500 s.f. min.	
Lot Frontage		A or B street, or two C streets (one at the front and one at the rear). See 660-12.J for front street designation regulations.		
2	Front Streetwall	25 ft. max. width per rowhouse		Measured in build-to zone along any front lot line.
3	Front Build-to Zone	10 ft. min.	10 ft. min.	See 660-126.G for front-yard averaging. Minimum streetscape area required per 660-12.L. See 660-18.J(1) for additional porch regulations.
		20 ft. max.	20 ft. max	
		Front-yard averaging applies		
4	Front Porch, Enclosed Porch Setback	5 ft. min.	5 ft. min.	
5	Side-Street Setback	10 ft. min.	0 ft. min.	
6	Side Setback	0 ft.; If any setback provided, at least 4 ft. required	0 ft.; If any setback provided, at least 4 ft. required	
7	Rear Setback	20 ft. min.	35 ft. min.; 15 ft. for lots less than 100 ft. deep without detached outbuilding or garage	
8	Rear Yard Landscape Area	–	15 ft. min. depth, 150 s.f. min. area.	
9	Building Coverage	70% max.	70% max.	See 660-126.I for measuring building coverage.

Figure 660-18(3) Town Rowhouse Parking Siting

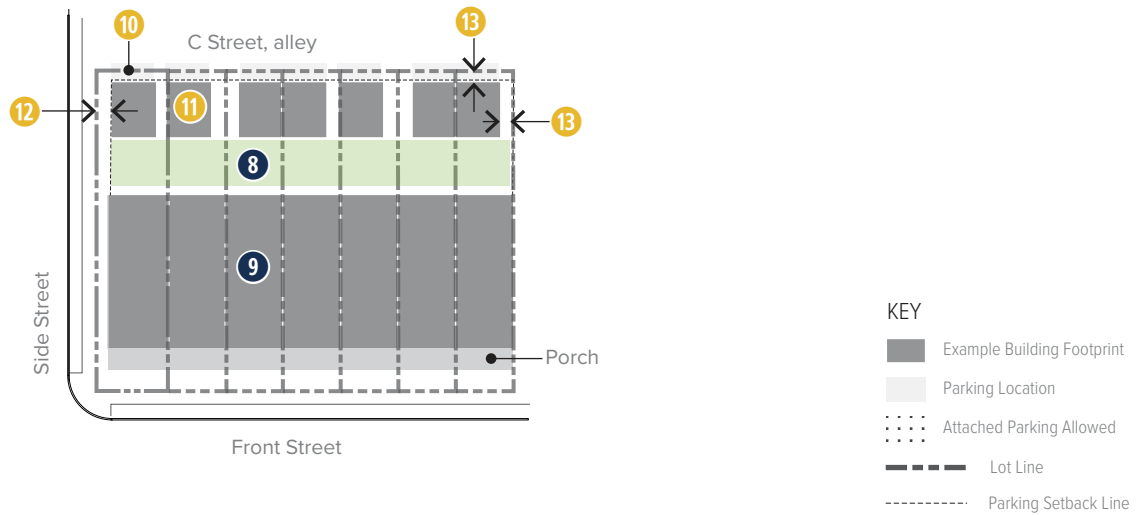

ZONES

GX-C

GX-N, N2

Additional/References

660-18.E. PARKING & ACCESSORY STRUCTURES. See Figure 660-18(3).				
10	Parking & Driveway Access	Driveway access is allowed per 660-12.K.		See Article 8 for parking.
	Attached Garage Setback	Attached garage not allowed		
	Allowed Garage Door Location (facade)	-		
11	Surface Parking & Accessory Structure Location	Rear yard	Rear yard	See Article 5 for accessory structures.
12	Side-Street Setback	No closer to lot line than principal building		
13	Side Setback	5 ft. min. total both sides	5 ft. min. total both sides	
	Rear Setback	3 ft. min.; 0 min. at improved alley for surface parking	3 ft. min.; 0 min. at improved alley for surface parking	
MAJOR ACCESSORY STRUCTURES				KEY: ● = Allowed ○ = Requires Special Exception - = Not Allowed
	Outbuildings (includes Detached Garages)	●	●	
	Drive-Through Facilities	-	-	
	Fuel Pumps	-	-	
	Outdoor Storage	-	-	
	Parking Structure	-	-	
660-18.F. NUMBER & LOCATION OF DWELLING UNITS				
	Principal Dwelling Units	1 in principal building	1 in principal building	See Article 4 for allowed uses and 660-36 for accessory dwelling unit requirements.
	Accessory Dwelling Units	1 in principal building	1 in principal building	

Figure 660-18(4) Town Rowhouse Height and Roofs

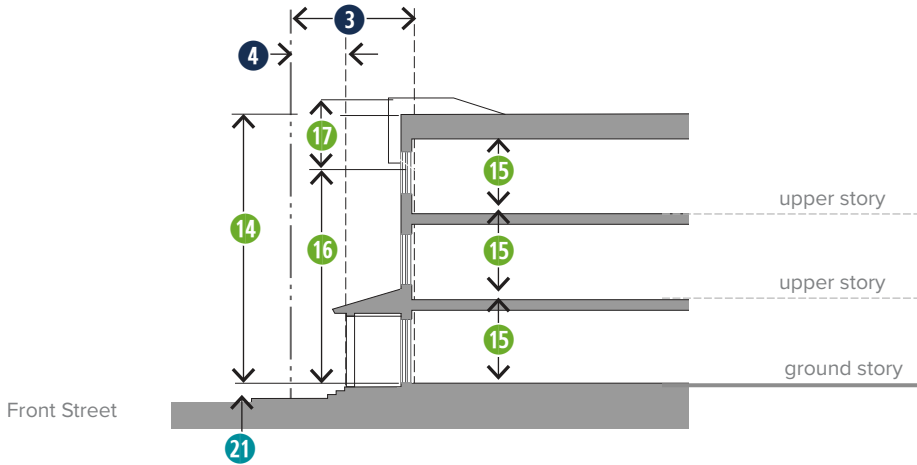

		ZONES		
		GX-C	GX-N, N2	Additional/References
660-18.G. HEIGHT. See Figure 660-18(4) .				
14	Height	2 stories min. 3 stories max.	2 stories min. 3 stories max.	See 660-126.M for measuring height.
15	Floor-to-Floor Height	9.5 ft. min. 11 ft. max.	9.5 ft. min. 11 ft. max.	Measured floor-to-floor.
16	Height to Eaves for Pitched Roofs	20 ft. max.	20 ft. max.	Height to eaves is measured from the first floor to the bottom of the eave. See 660-126.M for measuring height to eaves.
660-18.H. ROOFS. See Figure 660-18(4) .				
17	Allowed Roof Types	Pitched, Flat, Parapet	Pitched, Flat, Parapet	See 660-55 for roof types and towers.
		Dormers required on front facade of any Pitched roof with ridge parallel to street		
	Tower	Not allowed	Allowed only on corners of buildings at street intersections	

Figure 660-18(5) Town Rowhouse Facades

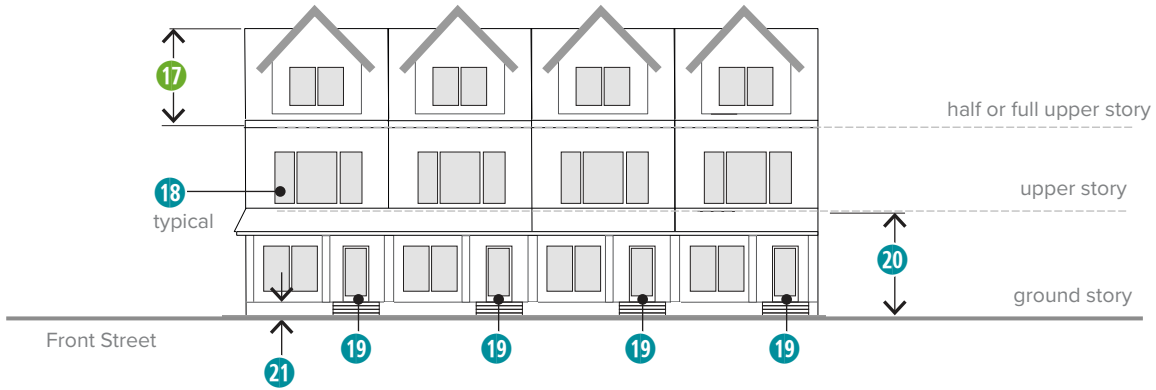

ZONES

		GX-C	GX-N, N2	Additional/References
660-18.I. FRONT & SIDE-STREET FACADES. See Figure 660-18(5)				
18	Transparency: Front Facades Side Facades	25% min. 15% min.	25% min. 15% min.	Measured per story, including any half stories, visible basement, or towers with full-floor height. See 660-126.N for measuring transparency.
		On the front facade, no bay nor 10-ft.-wide section of any story may be without transparency		
19	Entrance Location	Front facade	Front facade	
20	Allowed Entrance Types	Porch, Enclosed Porch, or Stoop	Porch, Enclosed Porch	See 660-57 for entrance types. See 660-18.J for additional porch regulations.
21	Ground-Floor Elevation	Between 12 in. and 30 in. above grade or between 30 in. and 48 in. with a visible basement		See 660-126.M for measuring elevation of ground floor.
	Horizontal Divisions with Shadow Lines	-		See 660-145 for definition of shadow lines.
	Vertical Divisions with Shadow Lines	-		

660-18.J SUPPLEMENTAL TOWN ROWHOUSE REGULATIONS

- (1) **Porch, Enclosed Porch in Front Yards.** Porches and enclosed porches allowed within the front yard porch setback area per 660-18.D, **4**, must meet the following:
- (a) **Height.** Porches and enclosed porches located in the front yard may be no taller than one story.
 - (b) **Porch.** See 660-57.C for porch and enclosed porches.
 - (c) **Size.** Porches must be at least half as wide of the front facade, meeting the minimum Porch entrance type regulations.
 - (d) **Other Allowed Encroachments.** See 660-126.G for other allowed encroachments into setbacks or build-to zones.
- (2) **Multiple Rowhouses on One Lot.** Multiple rowhouses may be located on a single lot provided the following:
- (a) Each rowhouse must meet all of the regulations as if each is located on a single lot, including front build-to zones located abutting a street lot line.
 - (b) Any interior side yards between multiple, connected rowhouse buildings must be at least 8 feet in width.
 - (c) Surface parking may be located in a rear or interior yard.

660-19 Urban Rowhouse

660-19.A DESCRIPTION AND INTENT

Urban Rowhouses are vertical units that may share side walls with one or two other units on separate abutting lots. Each unit is oriented to an A or B street, with an entrance from a stoop directly off the sidewalk or street. Parking is located in the rear yard and any garage access is from a rear facade.

660-19.B ILLUSTRATIVE IMAGES

The images shown in [Figure 660-19\(1\)](#) are intended to illustrate the general character of the building type. The buildings and sites in each image may not fulfill all of the building type regulations.

660-19.C BUILDING REGULATIONS

The following tables and illustrations regulate this specific building type and apply to each rowhouse. See [660-12](#) for general regulations for all building types. See [Article 13](#) for definitions and measuring table regulations.

LINK	SUBSECTION
660-19.D	Building Siting
660-19.E	Parking & Accessory Structures
660-19.F	Number & Location of Dwelling Units
660-19.G	Height
660-19.H	Roofs
660-19.I	Front & Side-Street Facades
660-19.J	Supplemental Regulations



Figure 660-19(1) Urban Rowhouse Building Type Examples

Figure 660-19(2) Urban Rowhouse Siting

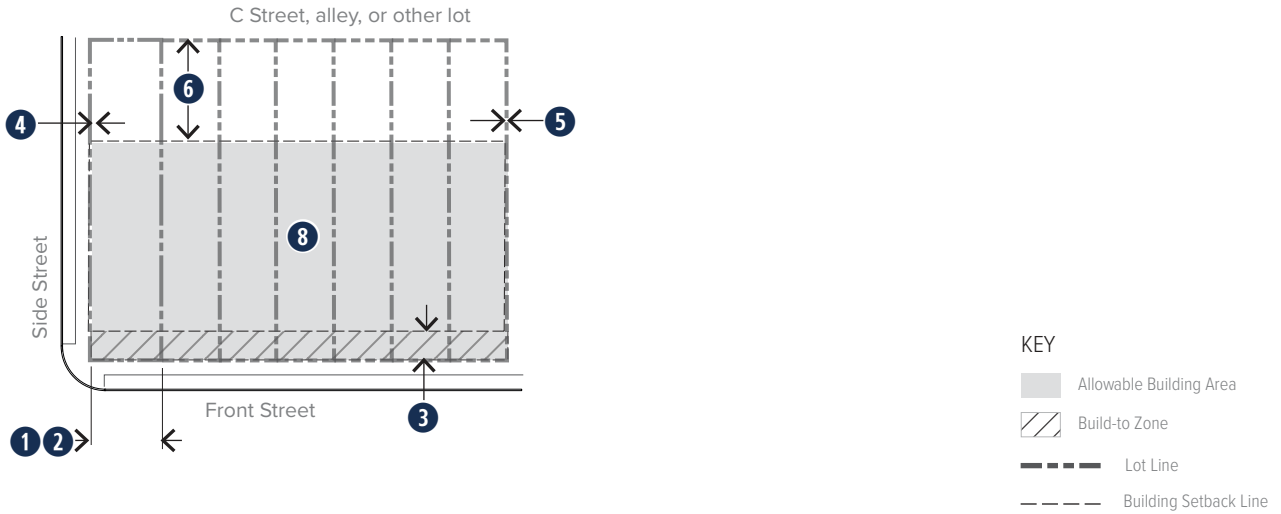

ZONES

MX-N, GX-N, N1

Additional/References

660-19.D. BUILDING SITING. See Figure 660-19(2)		
	Multiple Principal Buildings	Not allowed
1	Lot Width: Interior Unit End Unit	16 ft. min. 18 ft. min.
	Lot Size	1,500 s.f. min.
	Lot Frontage	A or B street, or two C streets (one at the front and one at the rear). See 660-12.J for front street designation regulations.
2	Front Streetwall	25 ft. max. width per rowhouse
3	Front Build-to Zone	0 ft. min. 8 ft. max Front-yard averaging applies
4	Side-Street Build-to Zone	0 ft. min. 20 ft. max.
5	Side Setback	0 ft; if any setback provided, at least 4 ft. required.
6	Rear Setback	35 ft. min.; 15 ft. for lots less than 100 ft. deep without detached outbuilding or garage
7	Rear Yard Landscape Area	15 ft. min. depth, 150 s.f. min. area.
8	Building Coverage	70% max.
		See 660-126.I for measuring building coverage.

Figure 660-19(3) Urban Rowhouse Parking Siting

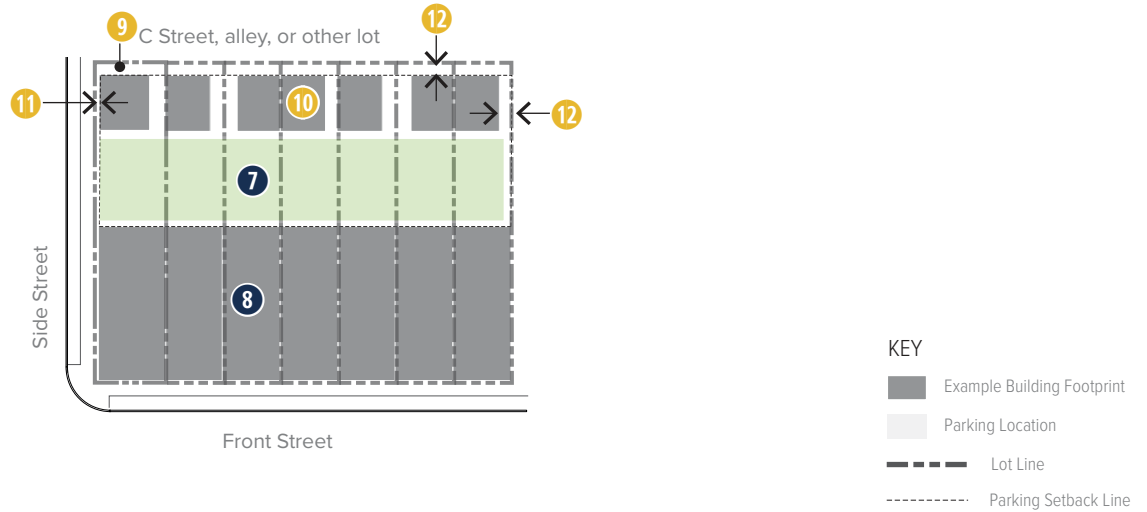

ZONES

MX-N, GX-N, N1

Additional/References

660-19.E. PARKING & ACCESSORY STRUCTURES. See Figure 660-19(3).			
9	Parking & Driveway Access	Driveway access is allowed per 660-12.K.	See Article 8 for parking.
	Attached Garage Setback	Attached garage not allowed	
	Allowed Garage Door Location (facade)	—	
10	Surface Parking & Accessory Structure Location	Rear yard	See Article 5 for accessory structures.
11	Street-Side Setback	No closer to lot line than principal building	
12	Side Setback	5 ft. min. total both sides	
	Rear Setback	3 ft. min.; 0 min. at improved alley for surface parking	
KEY ACCESSORY STRUCTURES			KEY: ● = Allowed ○ = Requires Special Exception — = Not Allowed
	Outbuildings (includes Detached Garages)	●	
	Drive-Through Facilities	—	
	Fuel Pumps	—	
	Outdoor Storage	—	
	Parking Structure	—	
660-19.F. NUMBER & LOCATION OF DWELLING UNITS			
	Principal Dwelling Units	1 in principal building	See Article 4 for allowed uses and 660-36 for accessory dwelling unit requirements.
	Accessory Dwelling Units	1 in principal building	

Figure 660-19(4) Urban Rowhouse Height and Roofs

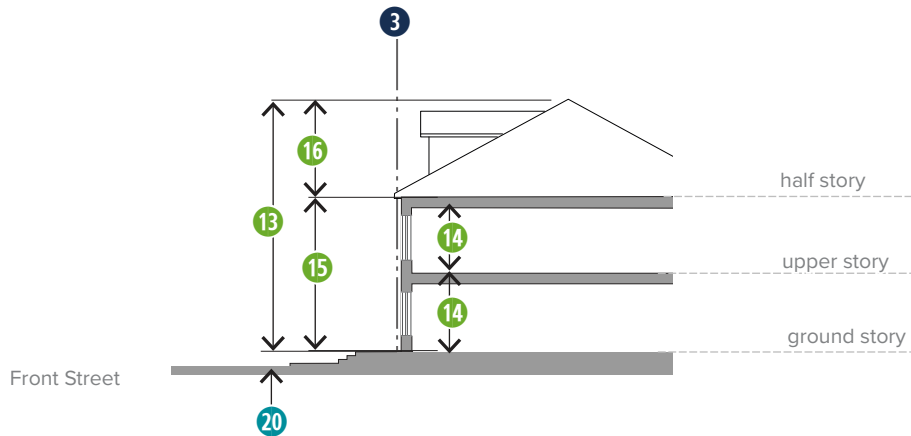

ZONES
MX-N, GX-N, N1

660-19.G. HEIGHT. See Figure 660-19(4).		Additional/References
13	Height	1.5 stories min. 2.5 stories max. with Pitched Roof or 3 stories max with Flat or Parapet Roof Type
14	Floor-to-Floor Height	9.5 ft. min. 11 ft. max.
15	Height to Eaves for Pitched Roofs	20 ft. max.
660-19.H. ROOFS. See Figure 660-19(4).		Additional/References
16	Allowed Roof Types	Pitched with ridge parallel to front lot line; Parapet, Flat
	Tower	Not allowed

Figure 660-19(5) Urban Rowhouse Facades

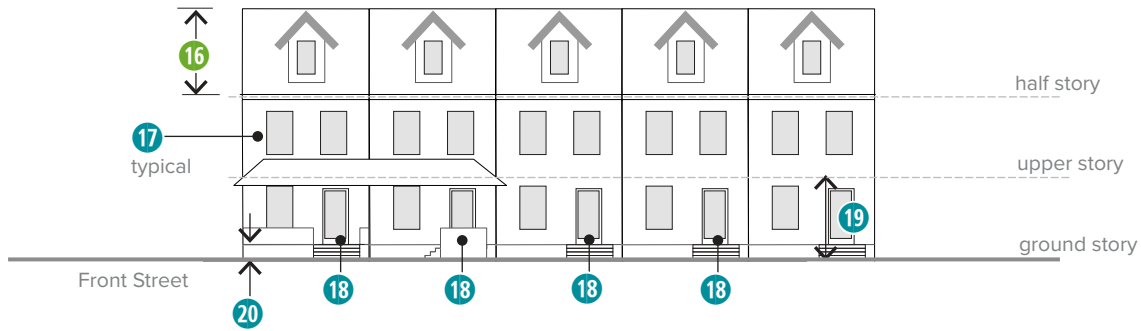

ZONES

MX-N, GX-N, N1

Additional/References

660-19.I. FRONT & SIDE-STREET FACADES. See Figure 660-19(5)

			Additional/References
17	Transparency: Front Facades Side Facades	15% min. 10% min. On the front facade, no bay nor 10-ft.-wide section of any story may be without transparency	Measured per story, including any half stories, visible basement, or towers with full-floor height. See 660-126.N for measuring transparency.
18	Entrance Location	Front or side-street facade	
19	Allowed Entrance Types	Stoop, Porch	See 660-57 for entrance types.
20	Ground-Floor Elevation	Between 12 in. and 30 in. above grade	
	Horizontal Divisions with Shadow Lines	–	See 660-145 for definition of shadow lines.
	Vertical Divisions with Shadow Lines	–	

660-19.J SUPPLEMENTAL URBAN ROWHOUSE REGULATIONS

- (1) Half Stories in Roof.** See 660-126.M(8) for definition of half story.
- (a)** The occupiable footprint of half stories in the roof is limited to no more than 65% of the footprint of story below.
 - (b)** Dormers on half stories are limited to no more than 50% of the facade length of the story below.

660-20 Lane Rowhouse

660-20.A DESCRIPTION AND INTENT

Lane Rowhouses are vertical, houses that may share side walls with other units on a separate lot, and that generally front on one C street with no other street access. Each Lane Rowhouse is oriented to the C street with an entrance and windows. Parking may be located off-site or to the side of the unit when rear access is not available.

660-20.B ILLUSTRATIVE IMAGES

The images shown in Figure 660-20(1) are intended to illustrate the general character of the building type. The buildings and sites in each image may not fulfill all of the building type regulations.

660-20.C BUILDING REGULATIONS

The following tables and illustrations regulate this specific building type and apply to each rowhouse. See 660-12 for general regulations for all building types. See Article 13 for definitions and measuring table regulations.

LINK	SUBSECTION
660-20.D	Building Siting
660-20.E	Parking & Accessory Structures
660-20.F	Number & Location of Dwelling Units
660-20.G	Height
660-20.H	Roofs
660-20.I	Front & Side-Street Facades
660-20.J	Supplemental Regulations



Figure 660-20(1) Lane Rowhouse Building Type Examples

Figure 660-20(2) Lane Rowhouse Siting

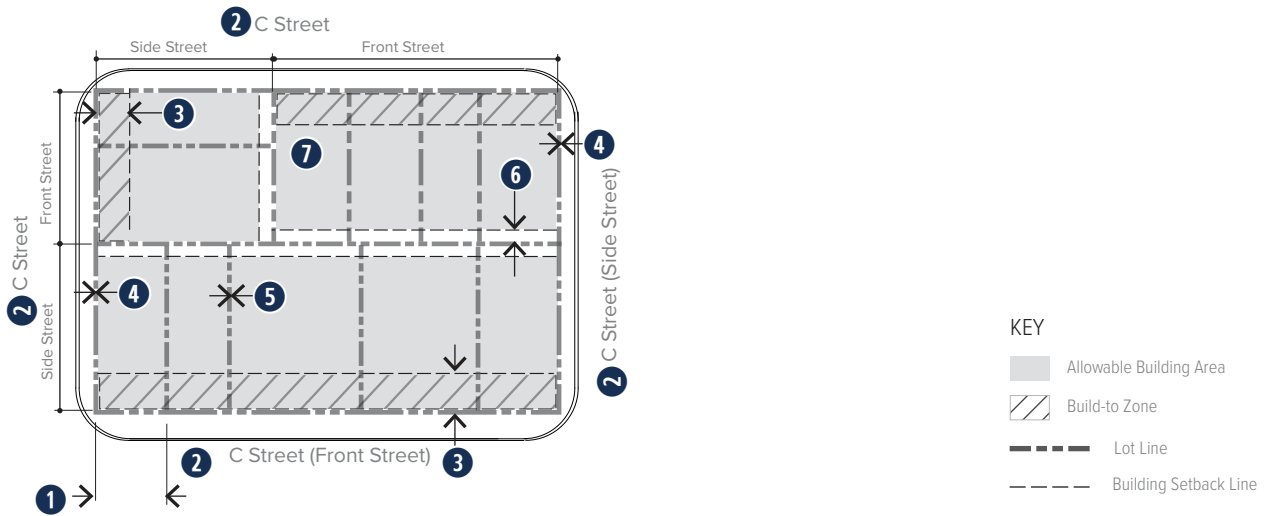

ZONE		
N1, N2		Additional/References

660-20.D. BUILDING SITING. See [Figure 660-20\(2\)](#)

Lane Rowhouse lots must exist on the day before the effective date specified in [660-01.C](#) in order to utilize these regulations. New Lane Rowhouses may be constructed only on existing lots meeting these regulations.

	Multiple Principal Buildings	Not allowed	
1	Lot Width Lot Size	14 ft. min. 600 s.f. min.	
2	Lot Frontage	On lots fronting on a C street with no other street access or at a corner of a C street with a C street only. See 660-12.J for front street designation regulations. With special exception approval, the Lane Rowhouse regulations may be approved for use on a lot fronting an A or B street or on the corner of an A or B street at a C street, provided the lot existed on the day before the effective date specified in 660-01.C , is no larger than 800 s.f., and has a width of no more than 20 ft.	
3	Front Build-to Zone	0 ft. min. 10 ft. max. Front-yard averaging applies	See 660-126.G for front-yard averaging. Minimum streetscape area per 660-12.L is not required on C streets.
4	Side-Street Setback	0 ft. min.	
5	Side Setback	0 ft; if any setback provided, at least 4 ft. required	
6	Rear Setback	5 ft. min.	
7	Building Coverage	85% max.	See 660-126.I for measuring building coverage.

Figure 660-20(3) Lane Rowhouse Parking Siting

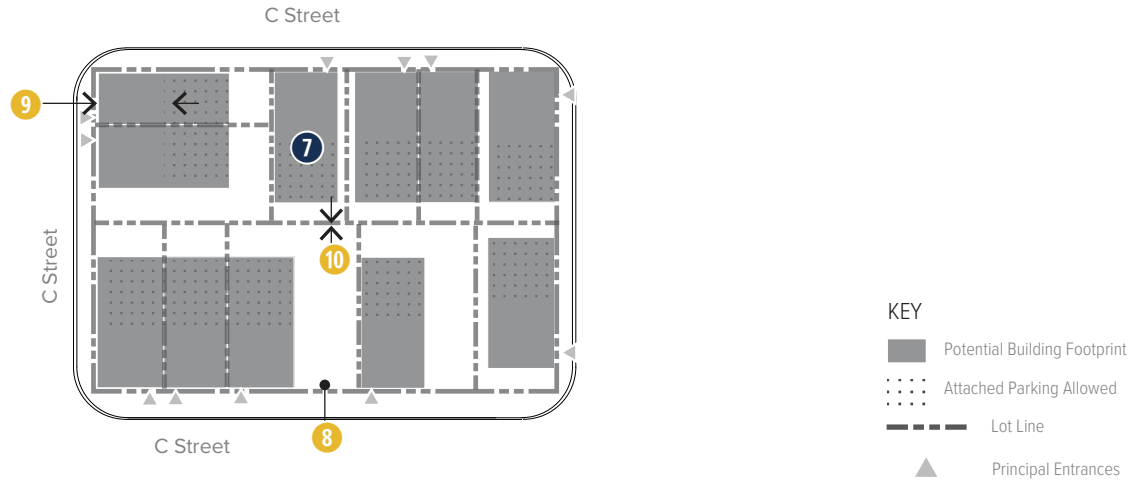

ZONE
N1, N2

660-20.E. PARKING & ACCESSORY STRUCTURES. See Figure 660-20(3).		Additional/References
8	Parking & Driveway Access	Driveway access is allowed per 660-12.K; max. 12 ft. width at lot line See Article 8 for parking.
9	Attached Garage Setback Allowed Garage Door Location (facade)	Rear of building; min. 15 ft. behind front facade Side-street, side, rear facade
10	Surface Parking & Accessory Structure Location	Street-side (C street at a C street only), side, rear yard See Article 5 for accessory structures.
	Street-Side Setback	No closer to lot line than principal building
	Side & Rear Setback	0 ft. min.
KEY ACCESSORY STRUCTURES		
	Outbuildings (includes Detached Garages)	●
	Drive-Through Facilities	-
	Fuel Pumps	-
	Outdoor Storage	-
	Parking Structure	-
660-20.F. NUMBER & LOCATION OF DWELLING UNITS		
	Principal Dwelling Units	1 in principal building unit See Article 4 for allowed uses.
	Accessory Dwelling Units	Not allowed

Figure 660-20(4) Lane Rowhouse Height and Roofs

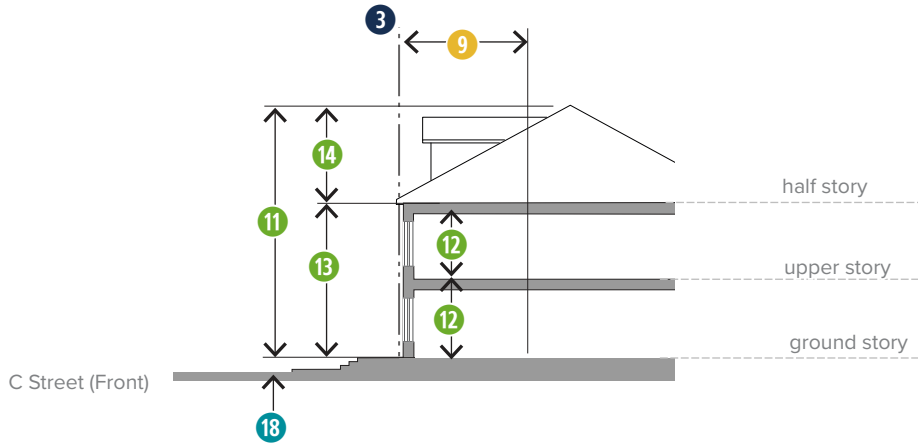

ZONE
N1, N2

660-20.G. HEIGHT. See Figure 660-20(4).		Additional/References	
11	Height	1.5 stories min. 2.5 stories max.	See supplemental regulations on half stories in 660-20.J. See 660-126.M for measuring height.
12	Floor-to-Floor Height	8.5 ft. min. 11 ft. max.	Measured floor-to-floor.
13	Height to Eaves for Pitched Roofs	20 ft. max.	Height to eaves is measured from the first floor to the bottom of the eave. See 660-126.M for measuring height to eaves.
660-20.H. ROOFS. See Figure 660-20(4).			
14	Allowed Roof Types	Pitched	See 660-55 for roof types and towers.
	Tower	Not allowed	

Figure 660-20(5) Lane Rowhouse Facades

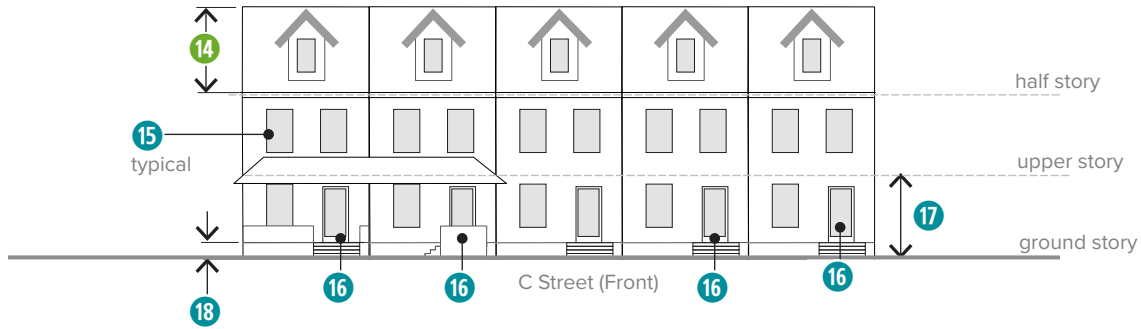

ZONE

N1, N2

Additional/References

660-20.I. FRONT & SIDE-STREET FACADES. See [Figure 660-20\(5\)](#)

			Additional/References
15	Transparency: Front Facades Side Facades	15% min. 10% min.	Measured per story, including any half stories, visible basement, or towers with full-floor height. See 660-126.N for measuring transparency.
		On the front facade, no bay nor 10-ft.-wide section of any story may be without transparency	
16	Entrance Location	Front, side-street, or side facade	
17	Allowed Entrance Types	Stoop, Porch Stoops that encroach into the r.o.w. require an encroachment permit.	See 660-57 for entrance types.
18	Ground-Floor Elevation	Between 12 in. and 30 in. above grade	
	Horizontal Divisions with Shadow Lines	–	See 660-145 for definition of shadow lines.
	Vertical Divisions with Shadow Lines	–	

**660-20.J SUPPLEMENTAL LANE ROWHOUSE
REGULATIONS**

- (1) Half Stories in Roof.** See 660-126.M.(8) for definition of half story.
- (a)** The occupiable footprint of half stories in the roof is limited to no more than 65% of the footprint of the story below.
 - (b)** Dormers on half stories are limited to no more than 50% of the facade length of the story below.

660-21 Suburban Rowhouse

660-21.A DESCRIPTION AND INTENT

Suburban Rowhouses are vertical units that share side walls with other units. Two or more units comprise a building, located on a single lot or multiple buildings may be located on a single lot. Or, as discussed in the supplemental regulations for the building type, each unit may be located on a separate lot (fee simple) with zero lot lines between the units. Each unit is oriented to an A or B street, with an entrance from a stoop or porch on the front of the building. Parking is located in the rear and any garage access is from a rear facade.

660-21.B ILLUSTRATIVE IMAGES

The images shown in Figure 660-21(1) are intended to illustrate the general character of the building type. The buildings and sites in each image may not fulfill all of the building type regulations.

660-21.C BUILDING REGULATIONS

The following tables and illustrations regulate this specific building type. For the purposes of the Suburban Rowhouse, a building consists of a series of units. See 660-11 for general regulations for all building types. See Article 13 for definitions and measuring table regulations.

LINK	SUBSECTION
660-21.D	Building Siting
660-21.E	Parking & Accessory Structures
660-21.F	Number & Location of Dwelling Units
660-21.G	Height
660-21.H	Roofs
660-21.I	Street Facades
660-21.J	Supplemental Regulations

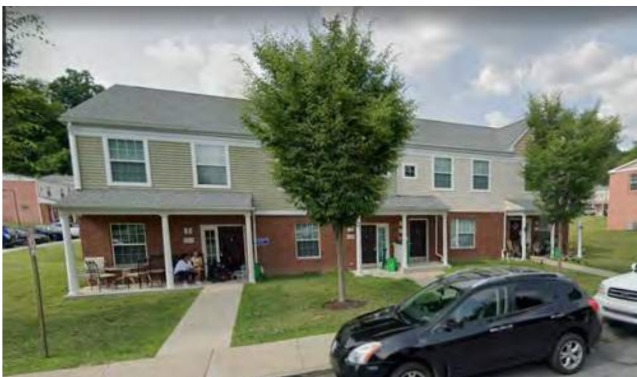
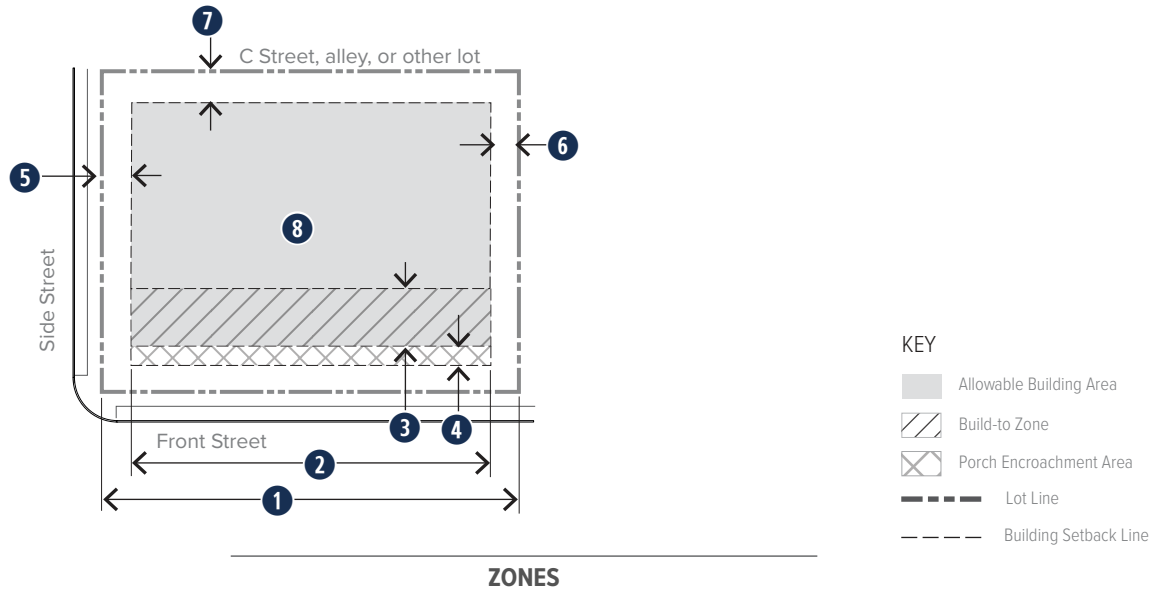

Figure 660-21(1) Suburban Rowhouse Building Type Examples

Figure 660-21(2) Suburban Rowhouse Siting



ZONES
GX-C, NX, N3

Additional/References

660-21.D. BUILDING SITING. See Figure 660-21(2)

660-21.D. BUILDING SITING. See Figure 660-21(2)		Additional/References	
	Multiple Principal Buildings	Allowed	See 660-21.J for multiple buildings on a lot.
1	Lot Width: Interior Unit End Unit	18 ft. min. per unit 28 ft. min. per unit	A "building" consists of attached multiple units.
	Lot Size	1,800 s.f. min.	
	Lot Frontage	A or B street. See 660-12.J for front street designation regulations.	
2	Building Width, maximum	8 rowhouse units	
3	Front Build-to Zone	15 ft. min. 25 ft. max. Front-yard averaging applies	See 660-126.G for front-yard averaging. Minimum streetscape area required per 660-12.L.
4	Front Porch, Enclosed Porch Setback	7.5 ft. min.	
5	Side-Street Build-to Zone	5 ft. min. 20 ft. max.	
6	Side Setback Space between Buildings	10 ft. min.; 0 ft. between units 12 ft. min.	
7	Rear Setback	10 ft. min.	
8	Building Coverage	60% max.	See 660-126.I for measuring building coverage.
9	Landscape Yard Area	15 ft. min. depth, 150 s.f. min. per unit; Landscape yard area may be located in the front, rear, side-street, or side yard, but must be located adjacent to unit.	

Figure 660-21(3) Suburban Rowhouse Parking

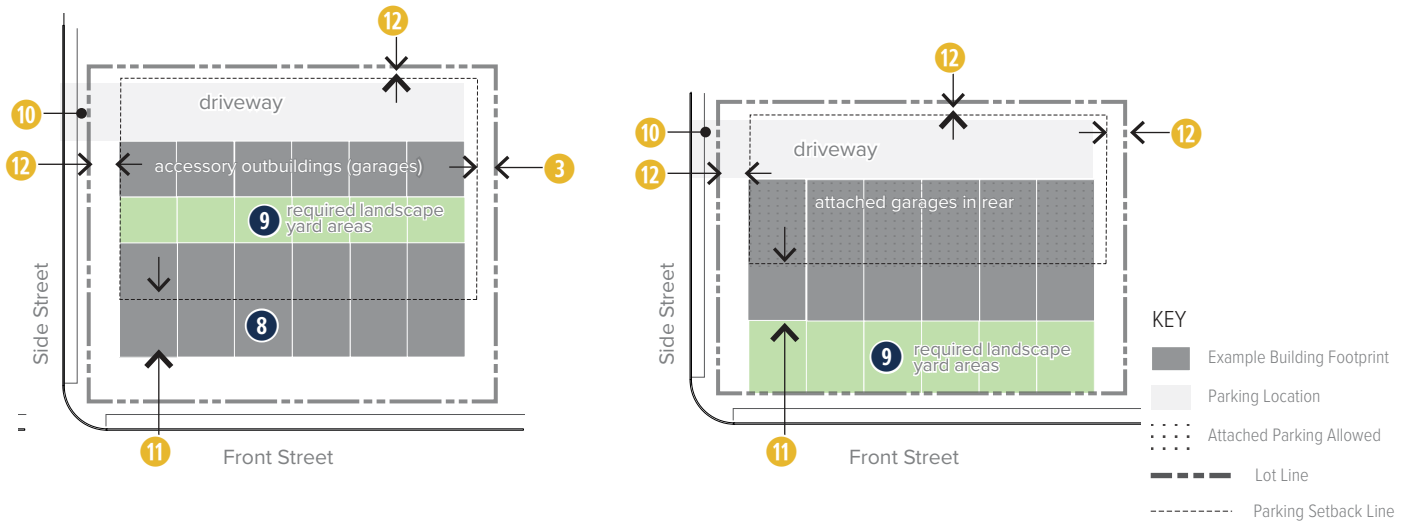

ZONES

GX-C, NX, N3

Additional/References

660-21.E. PARKING & ACCESSORY STRUCTURES. See Figure 660-21(3).			
10	Parking & Driveway Access	Driveway access is allowed per 660-12.K.	See Article 8 for parking.
11	Attached Garage Setback Allowed Garage Door Location (facade)	Min. 15 ft. behind front facade Rear; not visible from a front street and screened from side streets	
12	Surface Parking & Accessory Structure Location	Rear yard	See Article 5 for accessory structures.
	Street-Side Setback	No closer to lot line than principal building	
	Side & Rear Setback	3 ft. min.	
KEY ACCESSORY STRUCTURES			KEY:
	Outbuildings (includes Detached Garages)	●	● = Allowed
	Drive-Through Facilities	—	○ = Requires Special Exception
	Fuel Pumps	—	— = Not Allowed
	Outdoor Storage	—	
	Parking Structure	—	
660-21.F. NUMBER & LOCATION OF DWELLING UNITS			
	Principal Dwelling Units	1 in principal building unit	See Article 4 for allowed uses and 660-36 for accessory dwelling unit requirements.
	Accessory Dwelling Units	1 in principal building unit	

Figure 660-21(4) Suburban Rowhouse Height and Roofs

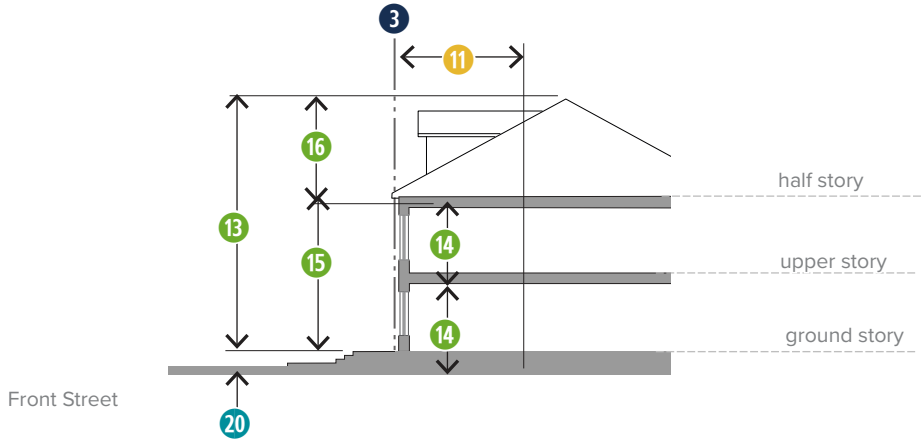

ZONES		
GX-C, NX, N3		Additional/References
660-21.G. HEIGHT. See Figure 660-21(4)		
13	Height	1.5 stories min. 2.5 stories max., except 3 stories max. for up to half of the units in a building
See supplemental regulations on half stories in 660-18.J. See 660-126.M for measuring height.		
14	Floor-to-Floor Height	9.5 ft. min. 11 ft. max.
Measured floor-to-floor.		
15	Height to Eaves for Pitched Roofs	20 ft. max.
Height to eaves is measured from the first floor to the bottom of the eave. See 660-126.M for measuring height to eaves.		
660-21.H. ROOFS. See Figure 660-21(4)		
16	Allowed Roof Types	Pitched; Parapet; Flat roof may be used for up to half of the units in a building
See 660-55 for roof types and towers.		
	Tower	Not allowed

Figure 660-21(5) Suburban Rowhouse Facades

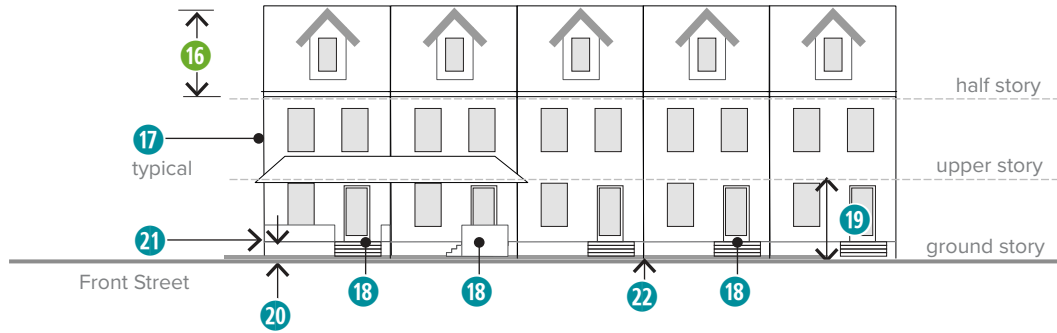

ZONES

GX-C, NX, N3

Additional/References

660-21.I. FRONT & SIDE-STREET FACADES. Facades. See [Figure 660-21\(5\)](#)

			Additional/References
17	Transparency: Front Facades Side-Street Facades	18% min. 12% min.	Measured per story, including any half stories, visible basement, or towers with full-floor height. See 660-126.N for measuring transparency.
		On the front facade, no bay nor 10-ft.-wide section of any story may be without transparency	
18	Unit Entrance Location	Front or side-street facade	See 660-21.J(4) for courtyards.
19	Allowed Entrance Types	Stoop, Porch; no more than 2 doors may share a porch or stoop	See 660-57 for entrance types. See 660-128 for definition of visible basement
20	Ground-Floor Elevation	Between 12 in. and 30 in. above grade, or 30 in. to 48 in. above grade with visible basement	
21	Horizontal Divisions with Shadow Lines	One shadow line within 3 ft. of any visible basement or the top of the first floor on any street facade	See 660-145 for definition of shadow lines.
22	Vertical Divisions with Shadow Lines	One shadow line per every 3 units on the ground story, front facade	

660-21.J SUPPLEMENTAL SUBURBAN ROWHOUSE REGULATIONS

- (1) **Porch, Enclosed Porch in Street Yards.** Porches and enclosed porches allowed within the porch setback area per 660-21.D, 4, must meet the following:
 - (a) **Height.** Porches and enclosed porches located in the street yard may be no taller than one story.
 - (b) **Porch.** See 660-57.C for porch and enclosed porch regulations.
 - (c) **Size.** Porches must be at least half as wide of the front facade, meeting the minimum Porch entrance type regulations.
 - (d) **Other Allowed Encroachments.** See 660-126.G for other allowed encroachments into setbacks or beyond build-to zones.
- (2) **Garage Door Visibility.** Garage doors must be screened from any street by the building or by a wing wall.
- (3) **Half Stories in Roof.** See 660-126.M(8) for definition of half story.
 - (a) The occupiable footprint of half stories in the roof is limited to no more than 65% of the footprint of story below.
 - (b) Dormers on half stories are limited to no more than 50% of the facade length of the story below.
- (4) **Multiple Buildings on a Lot.** Multiple buildings may be located on a lot with the following regulations:
 - (a) The minimum space between buildings is met.

- (b) Each building must fulfill all of the requirements of the building type unless otherwise expressly stated.
- (c) Each building must be located in the front or side-street build-to zone, except one of every 2 units may front a courtyard. See Figure 660-21(6).

- [1] The courtyard counts as front streetwall as long as 3 sides are enclosed at the minimum of 75%. One side of the courtyard may be defined by a landscape wall.
- [2] Parking is not allowed in the courtyard.
- [3] Street facade requirements apply to courtyard facades, treated as a front facade. If a unit is located on the corner of the courtyard and the street, the unit must use the street facade as the front facade.

- (5) **Each Unit on a Separate Lot.** Each unit may be located on a separate lot provided each unit and each building (combination of units) as a whole meets all of the regulations.

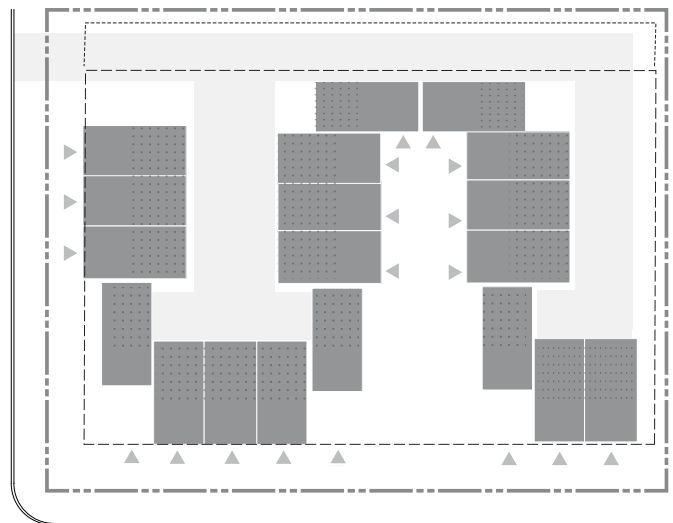
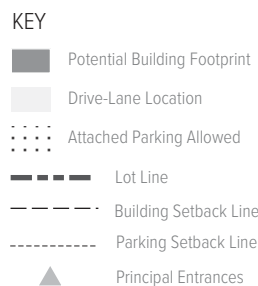

Figure 660-21(6) Courtyard Layout for Suburban Rowhouse

660-22 Twin House

660-22.A DESCRIPTION AND INTENT

The twin house is a house located on its own lot and sharing a common wall with another house on an abutting lot. Front facades are oriented to an A or B street and include windows on all stories and entrances located off front porches. Parking is typically located in the rear yard or in an accessory garage structure. Roofs vary in type, with a half story often located within a pitched roof structure.

660-22.B ILLUSTRATIVE IMAGES

The images shown in Figure 660-22(1) are intended to illustrate the general character of the building type. The buildings and sites in each image may not fulfill all of the building type regulations.

660-22.C BUILDING REGULATIONS

The following tables and illustrations regulate this specific building type and apply to each house. See 660-12 for general regulations for all building types. See Article 13 for definitions and measuring table regulations.

LINK	SUBSECTION
660-22.D	Building Siting
660-22.E	Parking & Accessory Structures
660-22.F	Number & Location of Dwelling Units
660-22.G	Height
660-22.H	Roofs
660-22.I	Front & Side-Street Facades
660-22.J	Supplemental Regulations

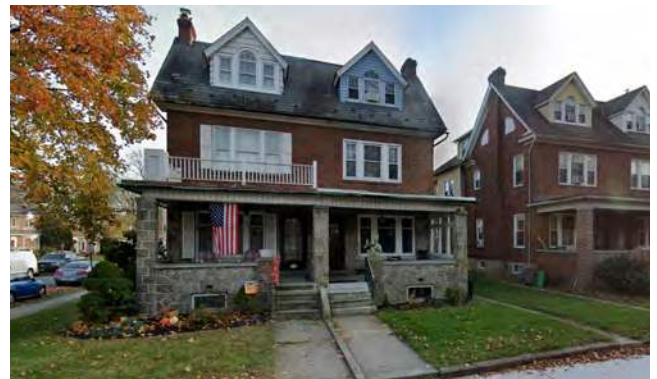
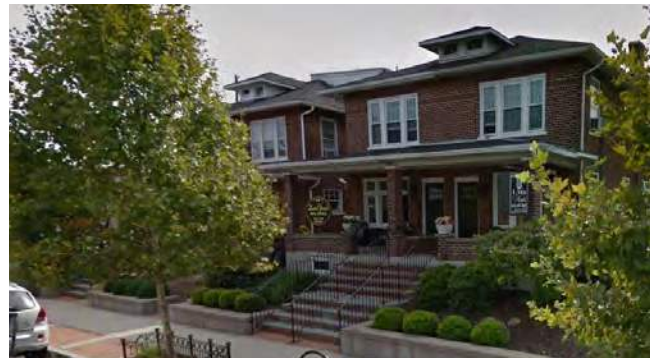
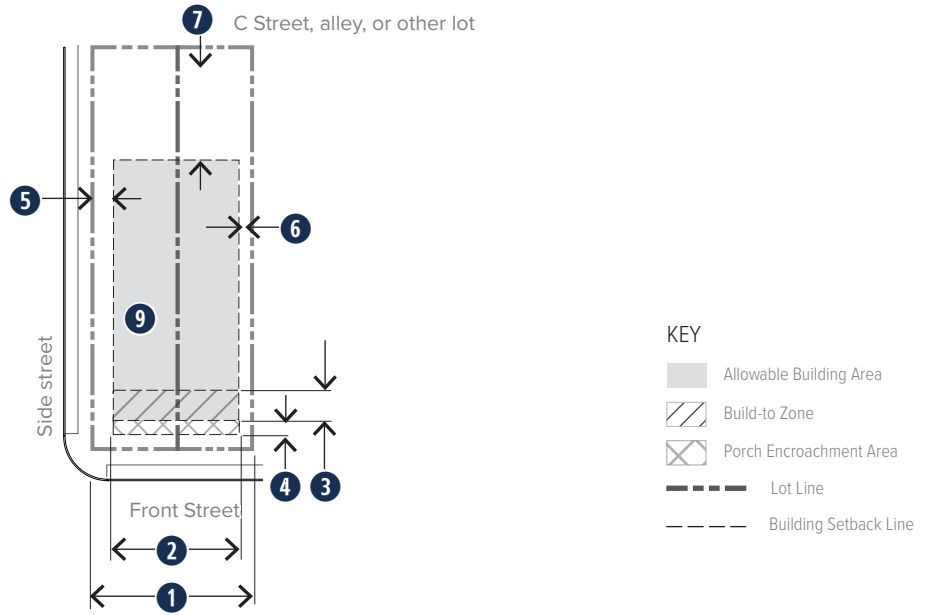

Figure 660-22(1) Twin House Building Type Examples

Figure 660-22(2) Twin House Siting



KEY

- Allowable Building Area
- Build-to Zone
- Porch Encroachment Area
- Lot Line
- Building Setback Line

ZONES				
	N3, N4	GX-C, GX-N	Additional/References	
660-22.D. BUILDING SITING. See Figure 660-22(2)				
	Multiple Principal Buildings	Not allowed	Not allowed	A building consists of two attached units.
1	Lot Width Lot Size	22 ft. min. 1,800 s.f. min.	20 ft. min. 1,800 s.f. min.	
	Lot Frontage	A or B street. See 660-12.J for front street designation regulations.		
2	Number of Connected Houses Front Streetwall of Connected Houses Combined	2 house units max. 55 ft. max.	2 house units max. 65 ft. max.	Measured in build-to zone along any street frontage.
3	Front Build-to Zone	10 ft. min. 20 ft. max.	10 ft. min. 20 ft. max.	See 660-126.G for front-yard averaging. Minimum streetscape area required per 660-12.L .
		Front-yard averaging applies		
4	Front Porch, Enclosed Porch Setback	8 ft. min.	5 ft. min.	
5	Side-Street Build-to Zone	10 ft. min. 30 ft. max.	10 ft. min. 30 ft. max.	
6	Side Setback	4 ft. min.; 0 ft. between units		
7	Rear Setback	35 ft. min.	20 ft. min.	
8	Rear Yard Landscape Area Depth	15 ft. min. depth, 150 s.f. min. area.	no min.	
9	Building Coverage	70% max.	70% max.	See 660-126.I for measuring building coverage.

Figure 660-22(3) Twin House Parking Siting

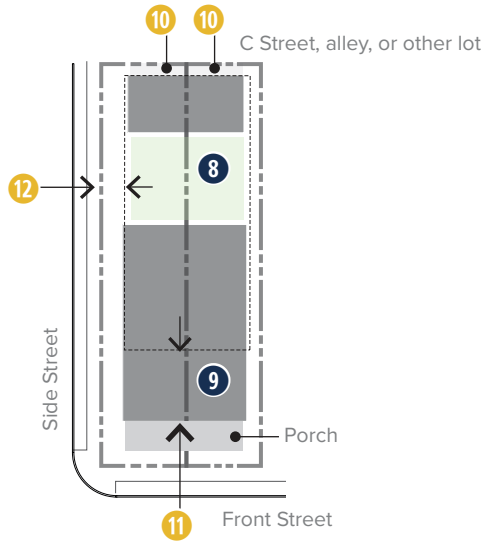

KEY	
	Example Building Footprint
	Attached Parking Allowed
	Lot Line
	Parking Setback Line

ZONES

		N3, N4	GX-C, GX-N	Additional/References
660-22.E. PARKING & ACCESSORY STRUCTURES. See Figure 660-22(3).				
10	Parking & Driveway Access	Driveway access is allowed per 660-12.K.		See Article 8 for parking.
11	Attached Garage Setback Allowed Garage Door Location (facade)	Rear of building; min. 20 ft. behind front facade Rear; not visible from front street and screened from side streets		
12	Surface Parking & Accessory Structure Location	Rear yard	Rear yard	See Article 5 for accessory structures.
	Side-Street Setback	No closer to lot line than principal building		
	Side & Rear Setback	3 ft. min.	3 ft. min.	
KEY ACCESSORY STRUCTURES				
	Outbuildings (includes Detached Garages)	●	●	KEY: ● = Allowed ○ = Requires Special Exception - = Not Allowed
	Drive-Through Facilities	-	-	
	Fuel Pumps	-	-	
	Outdoor Storage	-	-	
	Parking Structure	-	-	
660-22.F. NUMBER & LOCATION OF DWELLING UNITS				
	Principal Dwelling Units	1 in principal building	1 in principal building	See Article 4 for allowed uses and 660-36 for accessory dwelling unit requirements and 660-43 for outbuildings.
	Accessory Dwelling Units	1 in principal building or outbuilding	1 in principal building or outbuilding	

Figure 660-22(4) Twin House Height and Roofs

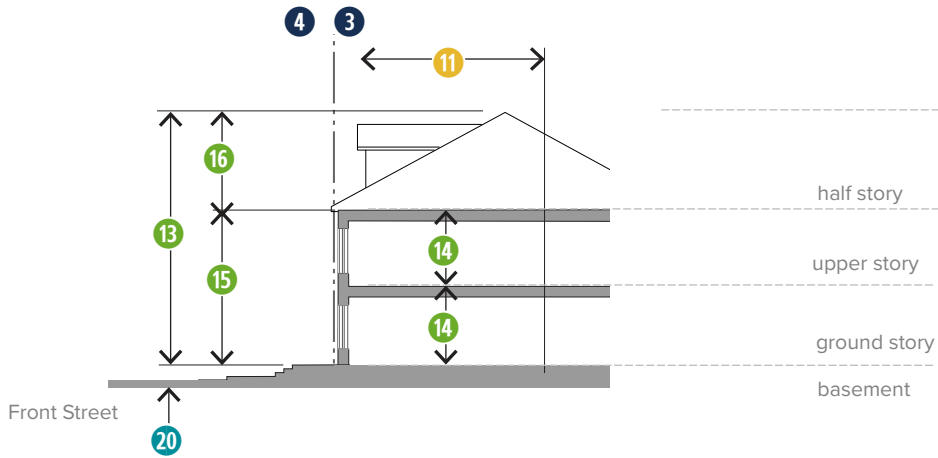

		ZONES		
		N3, N4	GX-C, GX-N	Additional/References
660-22.G. HEIGHT. See Figure 660-22(4)				
13	Height	1.5 stories min. 2.5 stories max.	1.5 stories min. 2.5 stories max.	See supplemental regulations on half stories in 660-22.J. See 660-126.M for measuring height.
14	Floor-to-Floor Height	9.5 ft. min. 11 ft. max.	9.5 ft. min. 11 ft. max.	Measured floor-to-floor.
15	Height to Eaves for Pitched Roofs	20 ft. max.	20 ft. max.	Height to eaves is measured from the first floor to the bottom of the eave. See 660-126.M for measuring height to eaves.
660-22.H. ROOFS. See Figure 660-22(4)				
16	Allowed Roof Types	Pitched, Flat, or Parapet; Dormers required on front facade of half stories in Pitched roof		See 660-55 for roof types and towers.
	Tower	Allowed only on one of the two attached units		

Figure 660-22(5) Twin House Facades

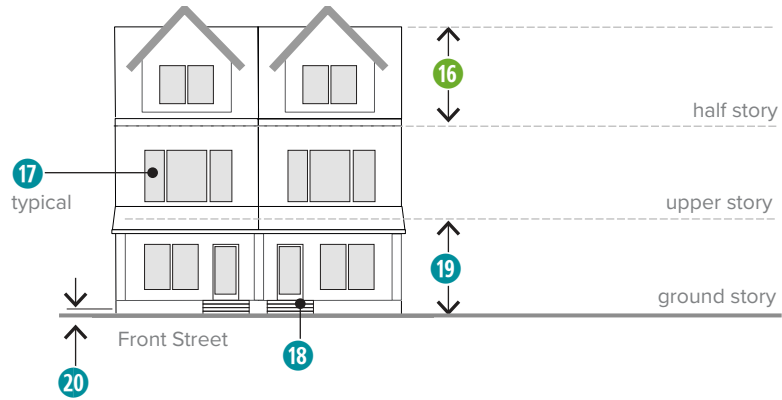

ZONES

N3, N4

GX-C, GX-N

Additional/References

660-22.I. FRONT & SIDE-STREET FACADES. See Figure 660-22(5)

	N3, N4	GX-C, GX-N	Additional/References
17 Transparency: Front Facades Side Facades	15% min. 10% min.	15% min. 10% min.	Measured per story, including any half stories, visible basement, or towers with full-floor height. See 660-126.N for measuring transparency.
	On the front facade, no bay nor 10-ft.-wide section of any story may be without transparency		
18 Entrance Location per House	Front facade	Front facade	
19 Allowed Entrance Types	Porch or Enclosed Porch	Porch or Enclosed Porch	See 660-57 for entrance types. See 660-128 for definition of visible basement
20 Ground-Floor Elevation	Between 18 in. and 30 in. above grade or between 30 in. and 48 in. with a visible basement		
Horizontal Divisions with Shadow Lines	-		See 660-145 for definition of shadow lines.
Vertical Divisions with Shadow Lines	-		

660-22.J SUPPLEMENTAL TWIN HOUSE REGULATIONS

- (1) **Porch, Enclosed Porch in Front Yards.** Porches and enclosed porches allowed within the front yard porch setback area per 660-22.D, ④, must meet the following:
- (a) **Height.** Porches and enclosed porches located in the front yard may be no taller than one story.
 - (b) **Porch.** See 660-57.C for porch and enclosed porch regulations.
 - (c) **Size.** Porches must be at least half as wide of the front facade, meeting the minimum Porch entrance type regulations.
 - (d) **Other Allowed Encroachments.** See 660-126.G for other allowed encroachments into setbacks or beyond build-to zones.
- (2) **Half Stories in Roof.** See 660-126.M.(8) for definition of half story.
- (a) The occupiable footprint of half stories in the roof is limited to no more than 65% of the footprint of story below.
 - (b) Dormers on half stories are limited to no more than 50% of the facade length of the story below. See Figure 660-22(6).

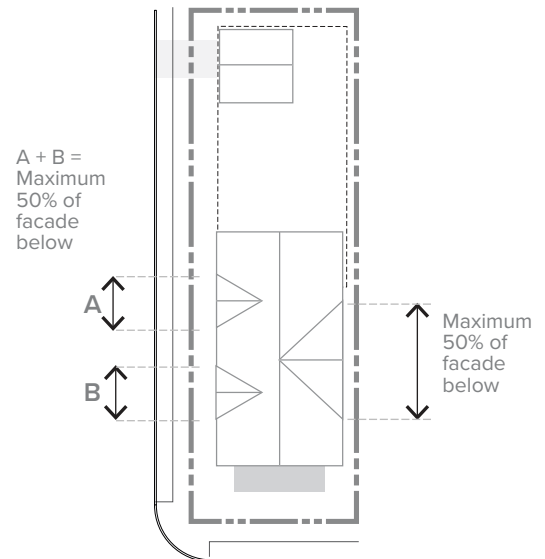

Figure 660-22(6) Dormers and Gable Ends on Half Stories.

660-23 House A

660-23.A DESCRIPTION AND INTENT

House A incorporates characteristics typical of houses at the turn of the century and those built prior to World War II, and, depending on the zone, may house residential or other uses. Parking for residential and commercial uses is located in the rear yard and accessed off an alley or C street. The houses are 2 or 2.5 stories in height with the half story located within a pitched roof. Front facades on the street include windows on all stories and entrances located off front porches or stoops.

660-23.B ILLUSTRATIVE IMAGES

The images shown in Figure 660-23(1) are intended to illustrate the general character of the building type. The buildings and sites in each image may not fulfill all of the building type regulations.

660-23.C BUILDING REGULATIONS

The following tables and illustrations regulate this specific building type. See 660-12 for general regulations for all building types. See Article 13 for definitions and measuring table regulations.

LINK	SUBSECTION
660-23.D	Building Siting
660-23.E	Parking & Accessory Structures
660-23.F	Number & Location of Dwelling Units
660-23.G	Height
660-23.H	Roofs
660-23.I	Front & Side-Street Facades
660-23.J	Supplemental Regulations



Figure 660-23(1) House A Building Type Examples

Figure 660-23(2) House A Building Siting

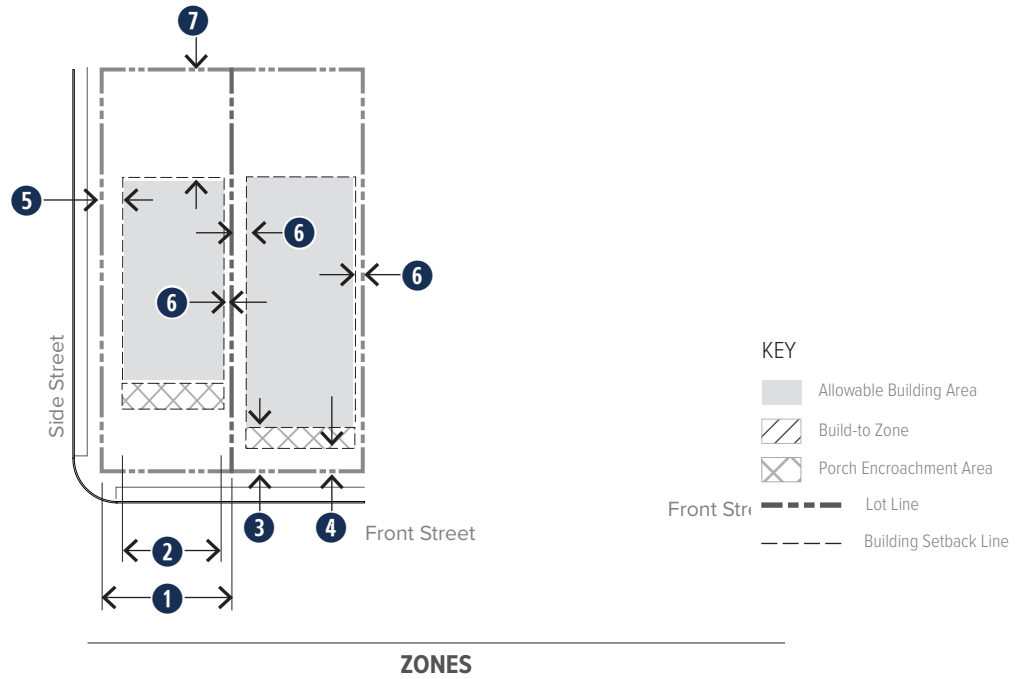

660-23.D. BUILDING SITING. See Figure 660-23(2)					
	GX-C	GX-N, NX, N2	N3, N4	Additional/References	
Multiple Principal Buildings	Not allowed	Not allowed	Not allowed		
1 Lot Width	60 ft. min.	40 ft. min.	40 ft. min.		
Lot Size	3,500 s.f. min.	2,000 s.f. min.	3,500 s.f. min.		
Lot Frontage	A or B street. See 660-12.J for front street designation regulations.				
2 Front Streetwall	65 ft. max.	45 ft. max.	50 ft. max.	Measured at front facade line along any front street.	
3 Front Setback or Build-to Zone	30 ft. min. -	15 ft. min. 25 ft. max.	15 ft. min. -	Front-yard averaging applies. See 660-126.G for measuring. See 660-23.J for allowed encroachments and enclosed porch configurations.	
4 Front Porch, Enclosed Porch Setback	20 ft. min.	5 ft. min.	8 ft. min.		
5 Side-Street Setback	10 ft. min.	5 ft. min.	10 ft. min.		
6 Side Setback	4 ft. min.	4 ft. min.	6 ft. min.		
7 Rear Setback	35 ft. min.	35 ft. min.	35 ft. min.		
8 Rear Landscape Yard	-	15 ft. min. depth; 150 s.f. min. area	15 ft. min. depth; 150 s.f. min. area		
9 Building Coverage	60% max.	60% max.	50% max.	See 660-126.I for measuring building coverage.	

Figure 660-23(3) House A Parking Siting

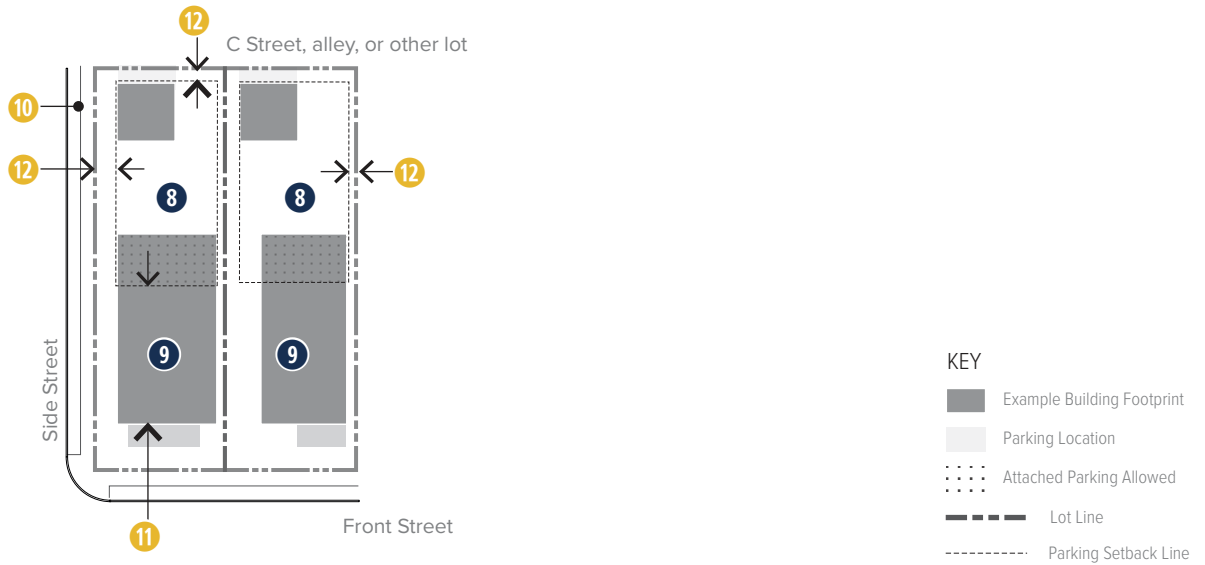

		ZONES			
		GX-C	GX-N, NX, N2	N3, N4	Additional/References
660-23.E. PARKING & ACCESSORY STRUCTURES. See Figure 660-23(3).					
10	Parking & Driveway Access	Driveway access is allowed per 660-12.K.			See Article 8 for parking.
11	Attached Garage Setback Allowed Garage Door Location	20 ft. min. behind front facade in rear of building Rear or side-street facade			
12	Surface Parking and Accessory Structure Location	Rear yard	Rear yard	Rear yard	See Article 5 for accessory structures.
	Street-Side Setback	No closer to lot line than principal building			
	Side & Rear Setback	3 ft. min.	3 ft. min.	3 ft. min.	
KEY ACCESSORY STRUCTURES					
	Outbuildings (includes Detached Garages)	●	●	●	KEY: ● = Allowed ○ = Requires Special Exception – = Not Allowed
	Drive-Through Facilities	–	–	–	
	Fuel Pumps	–	–	–	
	Outdoor Storage	–	–	–	
	Parking Structure	–	–	–	
660-23.F. NUMBER & LOCATION OF DWELLING UNITS					
	Principal Dwelling Units	up to 6 in principal building	up to 2 in principal building	1 in principal building	See Article 4 for allowed uses and 660-36 for accessory dwelling unit requirements and 660- 43 for outbuildings.
	Accessory Dwelling Units	–	–	1 in principal building or outbuilding	

Figure 660-23(4) House A Height and Roofs

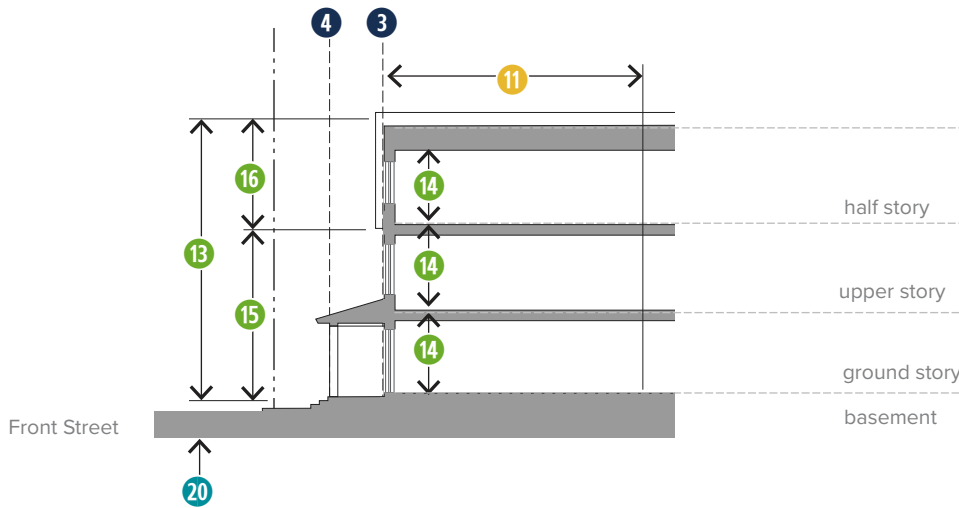

		ZONES			
		GX-C	GX-N, NX, N2	N3, N4	
660-23.G. HEIGHT. See Figure 660-23(4)					
13	Height	2 stories min. 2.5 stories max.; 3 stories max with both visible basement and half story in roof	1.5 stories min. 2.5 stories max.; 3 stories max with both visible basement and half story in roof	2 stories min. 2.5 stories max.	See 660-23.J for half story regulations. See 660-126.M for measuring height.
14	Story Height	9 ft. min. 12 ft. max.	9 ft. min. 11 ft. max.	9 ft. min. 11 ft. max.	Measured floor-to-floor.
15	Height to Eaves	20 ft. max.	20 ft. max.	20 ft. max.	Height to eaves is measured from the first floor to the bottom of the eave. See 660-126.M for measuring height to eaves.
660-23.H. ROOFS. See Figure 660-23(5)					
16	Allowed Roof Types	Pitched	Pitched	Pitched	See 660-55 for roof types and towers.
	Tower	Allowed	Allowed	Allowed	

Figure 660-23(5) House A Facades

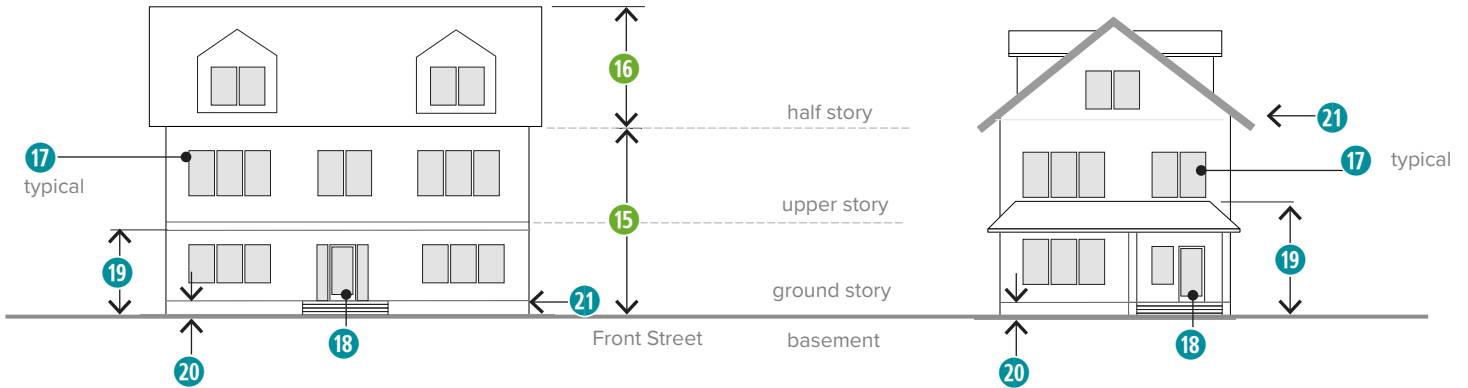

ZONES

		GX-C	GX-N, NX, N2	N3, N4	Additional/References
660-23.I. FRONT & SIDE-STREET FACADES. See Figure 660-23(5)					
17	Transparency: Front Facades Side-Street Facades	18% min. 12% min.	18% min. 12% min.	18% min. 12% min.	Measured per story, including any half stories, visible basement, or towers with full-floor height. See 660-126.N for measuring transparency.
		No bay nor 10-ft.-wide section of any story may be without transparency			
18	Building Entrance Location	Front facade	Front facade	Front facade	
19	Allowed Entrance Types	Porch or Stoop	Porch or Stoop	Porch or Stoop	See 660-57 for entrance types.
20	Ground-Floor Elevation	Between 12 in. and 30 in. above grade or between 30 in. and 48 in. with a visible basement			See 660-128 for definition of visible basement.
21	Horizontal Divisions with Shadow Lines	Within 3 ft. of the top of any visible basement and between 2nd and half story			See 660-145 for definition of shadow lines.

660-23.J SUPPLEMENTAL HOUSE A REGULATIONS

- (1) Porch, Enclosed Porch in Front Yards.** Porches and enclosed porches allowed within the front yard porch setback area per 660-23.D, 4, must meet the following:
- (a) Height.** Porches and enclosed porches located in the front yard may be no taller than one story.
 - (b) Porch.** See 660-57.C for porch and enclosed porch regulations.
 - (c) Size.** Porches must be at least half as wide of the front facade, meeting the minimum Porch entrance type regulations.
 - (d) Other Allowed Encroachments.** See 660-126.G.(3) for other allowed encroachments into setbacks or beyond build-to zones.
- (2) Half Stories in Roof.** See 660-126.M.(8) for definition of half story.
- (a)** The occupiable footprint of half stories in the roof is limited to no more than 65% of the footprint of story below.
 - (b)** Dormers on half stories are limited to no more than 50% of the facade length of the story below. See Figure 660-22(6).

660-24 House B

660-24.A DESCRIPTION AND INTENT

The smaller scale House B incorporates characteristics typical of houses built between the 1930s and 1960s in Allentown, including a footprint that is usually oriented parallel to the street. Parking is typically located in the rear yard or in a small garage on the front of the building. The houses are 1.5 to 2 stories in height; the half story is located within a steeply pitched roof with the main ridge parallel to the street. Floor-to-floor story heights are typically lower than House A, making even the two story versions appear lower in scale to a House A.

660-24.B ILLUSTRATIVE IMAGES

The images shown in Figure 660-24(1) are intended to illustrate the general character of the building type. The buildings and sites in each image may not fulfill all of the building type regulations.

660-24.C BUILDING REGULATIONS

The following tables and illustrations regulate this specific building type. See 660-12 for general regulations for all building types. See Article 13 for definitions and measuring table regulations.

LINK	SUBSECTION
660-24.D	Building Siting
660-24.E	Parking & Accessory Structures
660-24.F	Number & Location of Dwelling Units
660-24.G	Height
660-24.H	Roofs
660-24.I	Front & Side-Street Facades
660-24.J	Supplemental Regulations



Figure 660-24(1) House B Building Type Examples

Figure 660-24(2) House B Building Siting



ZONES

N3, N4, N5

Additional/References

660-24.D. BUILDING SITING. See [Figure 660-24\(2\)](#)

Multiple Principal Buildings		Not allowed; House B Court allowed per 660-24.J.1 , but each house must be on a separate lot	
1	Lot Width Lot Size	40 ft. min. 3,500 s.f. min.	
	Lot Frontage	A or B street. See 660-12.J for front street designation regulations.	
2	Front Setback	20 ft. min.	Front-yard averaging applies. See 660-126.G for measuring and allowed encroachments.
3	Side-Street Setback	10 ft. min.	
4	Side Setback	6 ft. min.	
5	Rear Setback	30 ft. min.	
6	Rear Yard Landscape Area	15 ft. min. depth; 150 s.f. min. area	
7	Building Coverage	40% max.	See 660-126.I for measuring building coverage.

Figure 660-24(3) House B Parking Siting

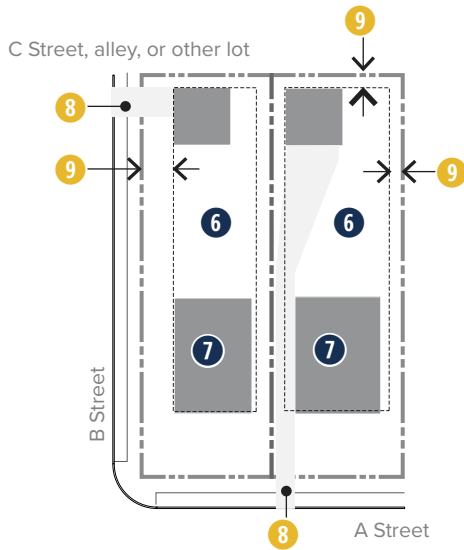

KEY

- Example Building Footprint
- Parking Location
- Lot Line
- Parking Setback Line

ZONES

N3, N4, N5

Additional/References

660-24.E. PARKING & ACCESSORY STRUCTURES. See Figure 660-24(3)		Additional/References
8	Parking & Driveway Access	Driveway access is allowed per 660-12.K.
	Attached Garage Setback	No setback required
	Allowed Garage Door Location	Any facade; front facade, max. 35% of facade
9	Surface Parking & Accessory Structure Location	Rear yard only
	Street-Side Setback	No closer to lot line than principal building
	Side & Rear Setback	3 ft. min.
MAJOR ACCESSORY STRUCTURES		
	Outbuildings (includes Detached Garages)	●
	Drive-Through Facilities	-
	Fuel Pumps	-
	Outdoor Storage	-
	Parking Structure	-
KEY:		
● = Allowed		
○ = Requires Special Exception		
- = Not Allowed		
660-24.F. NUMBER & LOCATION OF DWELLING UNITS		
	Principal Dwelling Units	1 in principal building
	Accessory Dwelling Units	1 in principal building or outbuilding
		See Article 4 for allowed uses and 660-36 for accessory dwelling unit requirements and 660-43 for outbuildings.

Figure 660-24(4) House B Height and Roofs

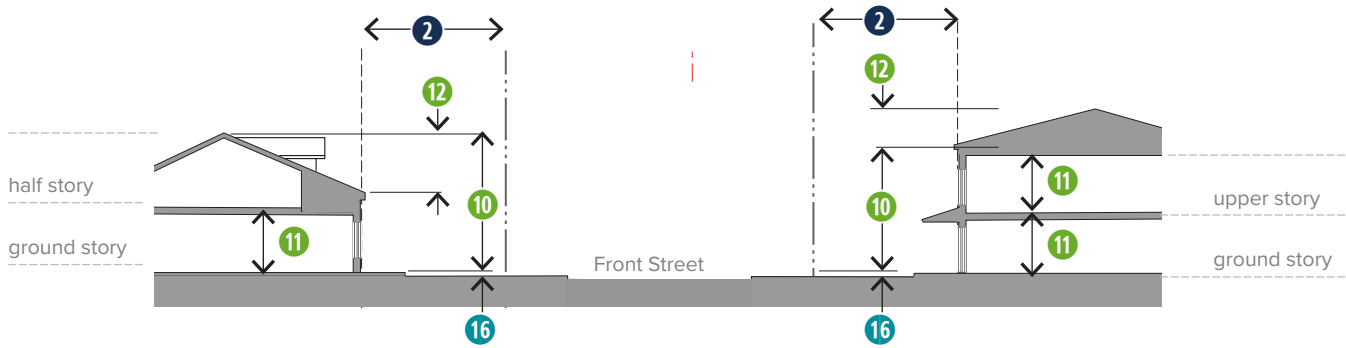

ZONES			
N3, N4, N5			
			Additional/References
660-24.G. HEIGHT. See Figure 660-24(4)			
10	Height	1 story min. 2 stories max.	See 660-126.M for measuring height. See 660-24.J(2) for basement garage allowance.
11	Story Height	8 ft. min. 9 ft. max.	Measured floor-to-floor.
660-24.H. ROOFS. See Figure 660-24(4)			
12	Allowed Roof Types	Pitched	See 660-55 for roof types.
	Tower	Not allowed	

Figure 660-24(5) House B Facades

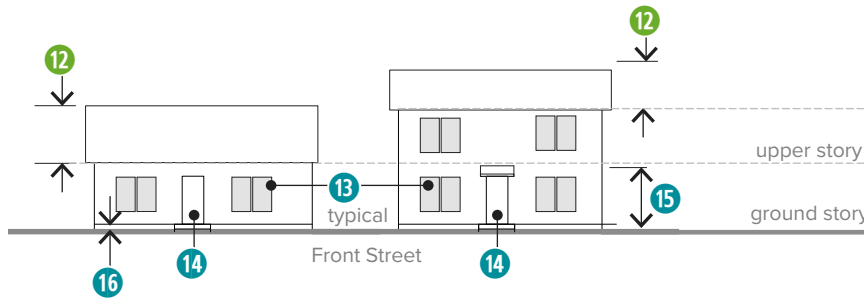

ZONES

N3, N4, N5

Additional/References

660-24.I. FRONT & SIDE-STREET FACADES. See Figure 660-24(5)

		ZONES		Additional/References
		N3, N4, N5		
13	Transparency: Front Facades Side-Street Facades	12% min. 10% min.		Measured per story, including any half stories, visible basement, or towers with full-floor height. See 660-126.N for measuring transparency.
		On front facades, no bay nor 10-ft.-wide section of any story may be without transparency		
14	Building Entrance Location	Front, street-side, or side facade		
15	Allowed Entrance Types	Porch or Stoop		See 660-57 for entrance types.
16	Ground-Floor Elevation	Between 0 and 30 in. above grade or between 30 in. and 48 in. with a visible basement		See 660-24.J(2) for basement garage allowance. See 660-128 for definition of visible basement.

660-24.J SUPPLEMENTAL HOUSE B REGULATIONS

- (1) **House B Court.** See [Figure 660-24\(6\)](#) for one layout of the following regulations. Multiple principal House B buildings may be located on separate lots fronting a courtyard as follows:
 - (a) All houses and lots must be submitted and developed at the same time.
 - (b) Each house must be located on a separate lot within the development.
 - (c) Each building must fulfill all of the requirements of the building type unless otherwise expressly stated.
 - (d) At least 2 houses must be located fronting along the street and no more than 8 houses may front the courtyard.
 - (e) The front street setback for houses fronting the courtyard is measured from the edge or lot line of the courtyard area, and the courtyard facade is the front facade.
 - (f) The 2 houses fronting the street must have front entrances on the street facade.

- (g) **Courtyard Frontage.** A courtyard minimum 50 feet wide and 50 feet deep must be located within the center of the development.
 - [1] The courtyard must be generally enclosed on 3 sides by front facades of House B buildings, fronting the street. One side of the courtyard may be defined by a landscape wall.
 - [2] The courtyard must be treated as landscape area and may not include any parking.
 - [3] The courtyard must be designated as common open space and included in a deed-restricted covenant as such.
 - [4] Facade requirements apply to courtyard facades. If a unit is located on the corner of the courtyard and the street, the entrance must be located on the street.
 - [5] Attached garages must be set back a minimum of 20 feet from any courtyard facade.
- (h) A shared driveway must serve all units providing access to rear- or side-loaded garages. An



Figure 660-24(6) House B Court Layout Example

access easement must be granted for each lot on the shared driveway and the driveway must be designated as shared access in a deed-restricted covenant.

- (i) An alternative House B court layout may be approved as a special exception per 660-110.
- (2) Full Height Basement Garage.** Where the existing grade at the house foundation is 4 feet or more above the average curb or edge of pavement elevation, a full-story-height basement may be incorporated for a garage on the front facade. The basement garage may not occupy more than 50% the width of the house. That full height basement counts as a half story towards the overall allowed maximum height of the building.



Figure 660-24(7) Full Height Basement Garage

[page intentionally blank]

660-25 House C

660-25.A DESCRIPTION AND INTENT

House C is the most flexible house type and incorporates basic regulations for a variety of house designs. Garages may be included on the front facade, unlike most other house building types.

660-25.B ILLUSTRATIVE IMAGES

The images shown in Figure 660-25(1) are intended to illustrate the general character of the building type. The buildings and sites in each image may not fulfill all of the building type regulations.

660-25.C BUILDING REGULATIONS

The following tables and illustrations regulate this specific building type. See 660-12 for general regulations for all building types. See Article 13 for definitions and measuring table regulations.

LINK	SUBSECTION
660-25.D	Building Siting
660-25.E	Parking & Accessory Structures
660-25.F	Number & Location of Dwelling Units
660-25.G	Height
660-25.H	Supplemental Regulations



Figure 660-25(1) House C Building Type Examples

Figure 660-25(2) House C Building Siting

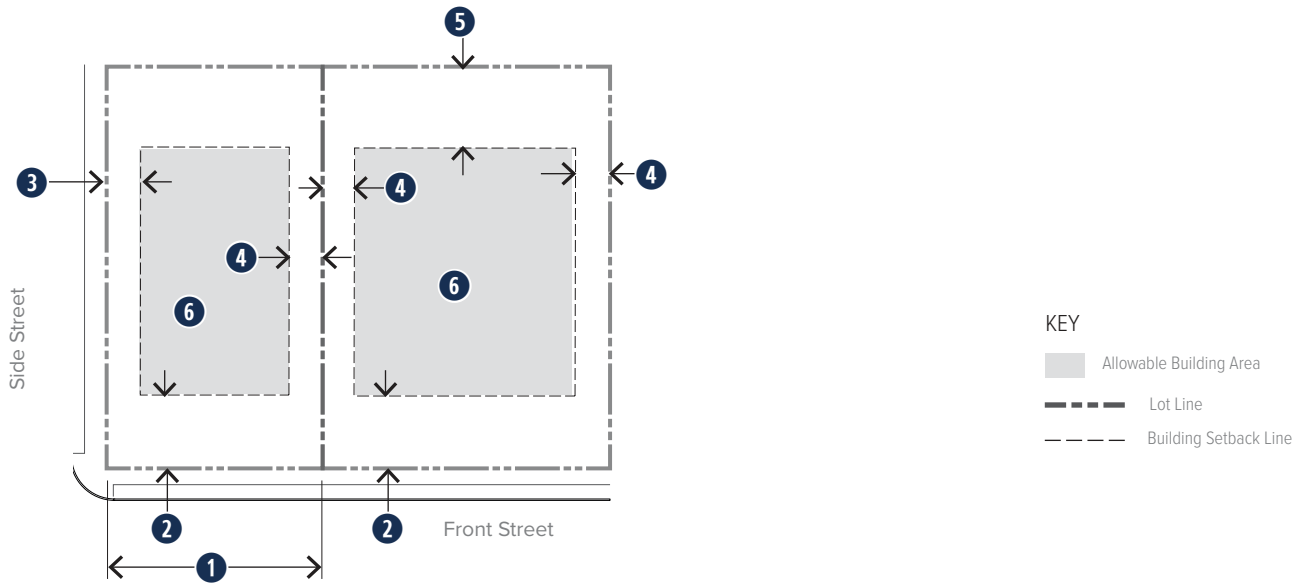

ZONES

N5

Additional/References

660-25.D. BUILDING SITING. See Figure 660-25(2)		
	Multiple Principal Buildings	Not allowed
1	Lot Width Lot Size	50 ft. min. 6,000 s.f. min.
	Lot Frontage	A or B street. See 660-12.J for front street designation regulations.
2	Front Setback	25 ft. min. Front-yard averaging applies. See 660-126.G for measuring and allowed encroachments.
3	Side-Street Setback	15 ft. min.
4	Side Setback	7 ft. min. with total of 16 ft. min.
5	Rear Setback	30 ft. min.
6	Building Coverage	30% max.

Figure 660-25(3) House C Parking Siting

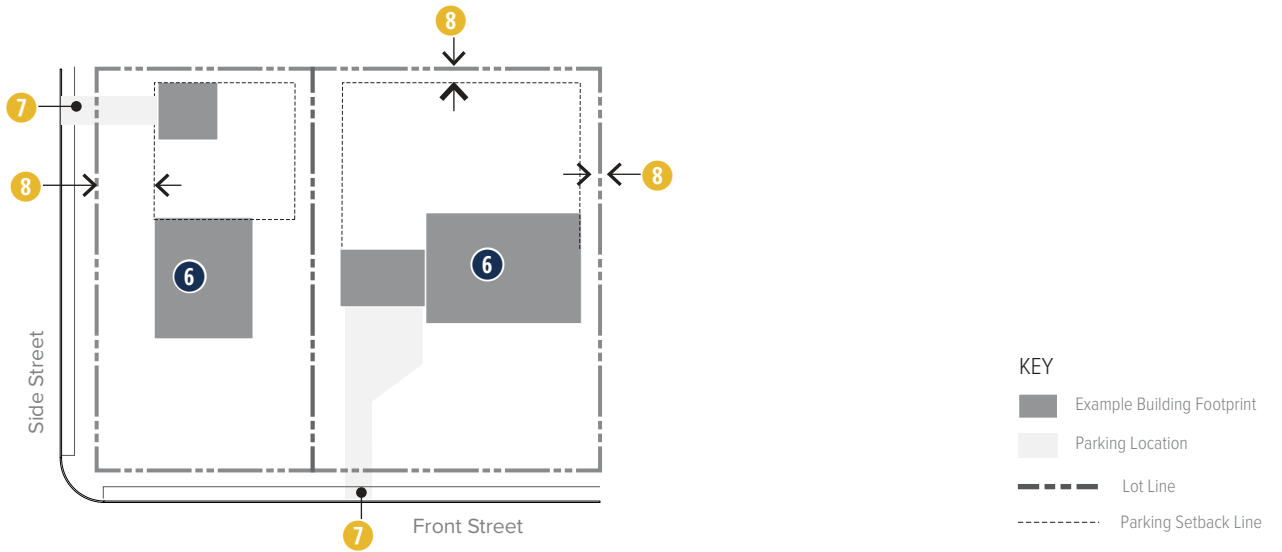

ZONES

N5

Additional/References

660-25.E. PARKING & ACCESSORY STRUCTURES. See Figure 660-25(3)

7	Parking Access	Driveway access is allowed per 660-12.K.	
8	Accessory Structure Location	Rear yard	See Article 5 for accessory structures.
	Street-Side Setback	No closer to lot line than principal building	
	Side & Rear Setback	5 ft. min.	

KEY ACCESSORY STRUCTURES

Outbuildings (includes Detached Garages)	●	KEY: ● = Allowed ○ = Requires Special Exception – = Not Allowed
Drive-Through Facilities	–	
Fuel Pumps	–	
Outdoor Storage	–	
Parking Structure	–	

660-25.F. NUMBER & LOCATION OF DWELLING UNITS.

Principal Dwelling Units	1 in principal building	See Article 4 for allowed uses and 660-36 for accessory dwelling unit requirements and 660-43 for outbuildings.
Accessory Dwelling Units	1 in principal building or outbuilding	

660-25.G. HEIGHT.

9	Height	1 story min. 2.5 stories max., 38 ft. max.	See 660-126.M for measuring height.
---	--------	---	-------------------------------------

660-25.H SUPPLEMENTAL HOUSE C REGULATIONS

(1) [reserved]

660-26 Workshop Building

660-26.A DESCRIPTION AND INTENT

The Workshop building accommodates larger interior spaces primarily for production and manufacturing with a minimum level of orientation to the sidewalk and pedestrians. In more visible locations, the front of the building has regulations similar to the General building and a "high-bay space" is allowed behind that portion of the building.

660-26.B ILLUSTRATIVE IMAGES

The images shown in [Figure 660-26\(1\)](#) are intended to illustrate the general character of the building type. The buildings and sites in each image may not fulfill all of the building type regulations.

660-26.C BUILDING REGULATIONS

The following tables and illustrations regulate this specific building type. See [660-12](#) for general regulations for all building types. See [Article 13](#) for definitions and measuring table regulations.

LINK	SUBSECTION
660-26.D	Building Siting
660-26.E	Parking & Accessory Structures
660-26.F	Height
660-26.G	Front & Side-Street Facades
660-26.H	Supplemental Regulations



Figure 660-26(1) Workshop Building Type Examples

Figure 660-26(2) Workshop Building Siting

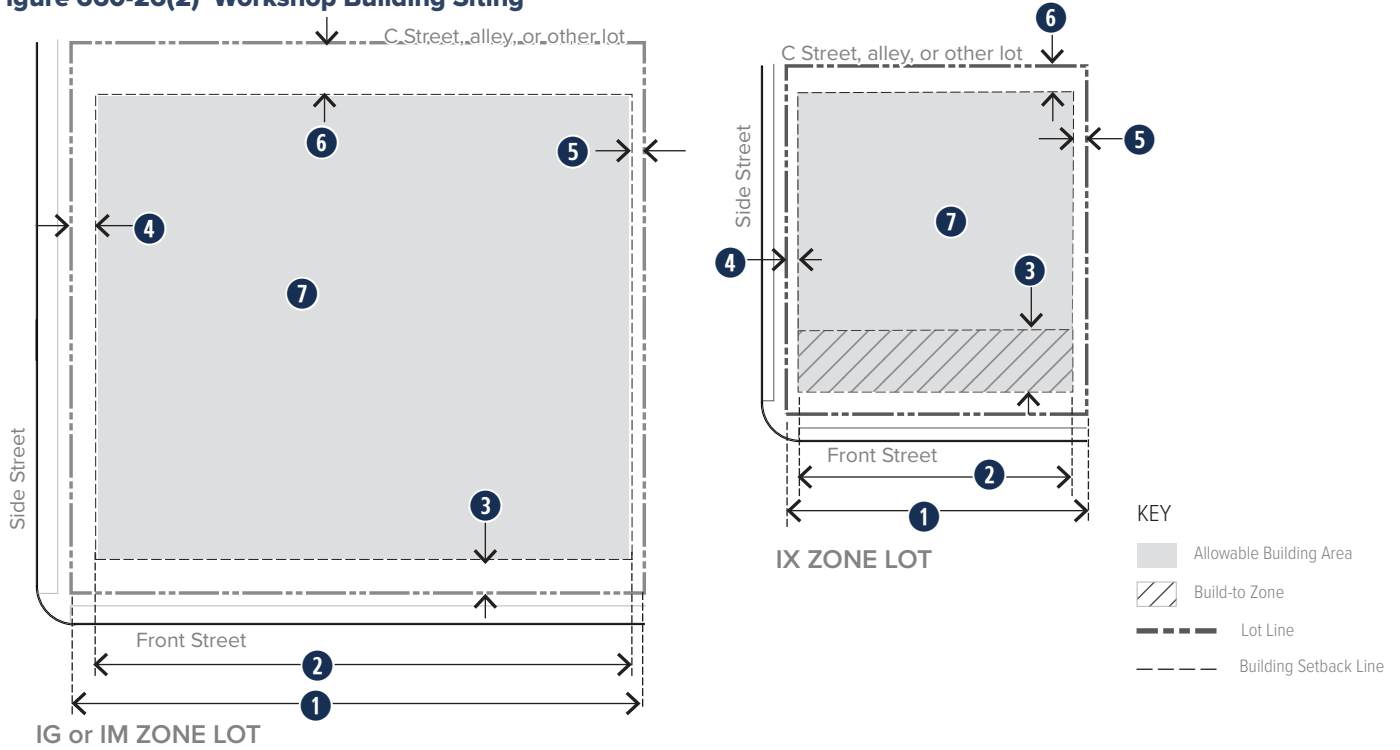

ZONES

	IX, P1, P2	IG, IM	Additional/References
660-26.D. BUILDING SITING. See Figure 660-26(2)			
Allowed per Table 660-2	Allowed in IX; allowed in P1 and P2 zones by special exception.	Allowed	
Multiple Principal Buildings	Allowed	Allowed	
1 Lot Width	40 ft. min.	80 ft. min.	
Lot Frontage	A or B street. See 660-12.J for front street designation regulations.		
2 Front Streetwall	35% min.	–	
3 Front Build-to Zone or Setback	10 ft. min. 35 ft. max.	10 ft. min. setback –	Minimum streetscape area required per 660-12.L .
4 Side-Street Setback	5 ft. min.	10 ft. min.	
5 Side Setback Side Setback Adjacent to N Zone Space between Buildings	8 ft. min. 15 ft. min. 12 ft. min.	8 ft. min. 15 ft. min. 12 ft. min.	See 660-73 for landscape buffer adjacent to N zones.
6 Rear Setback Rear Setback Adjacent to N Zone	10 ft. min. 30 ft. min.	10 ft. min. 30 ft. min.	
7 Building Coverage	85% max.	85% max.	See 660-126.I for measuring building coverage.

Figure 660-26(3) Workshop Building Parking Siting

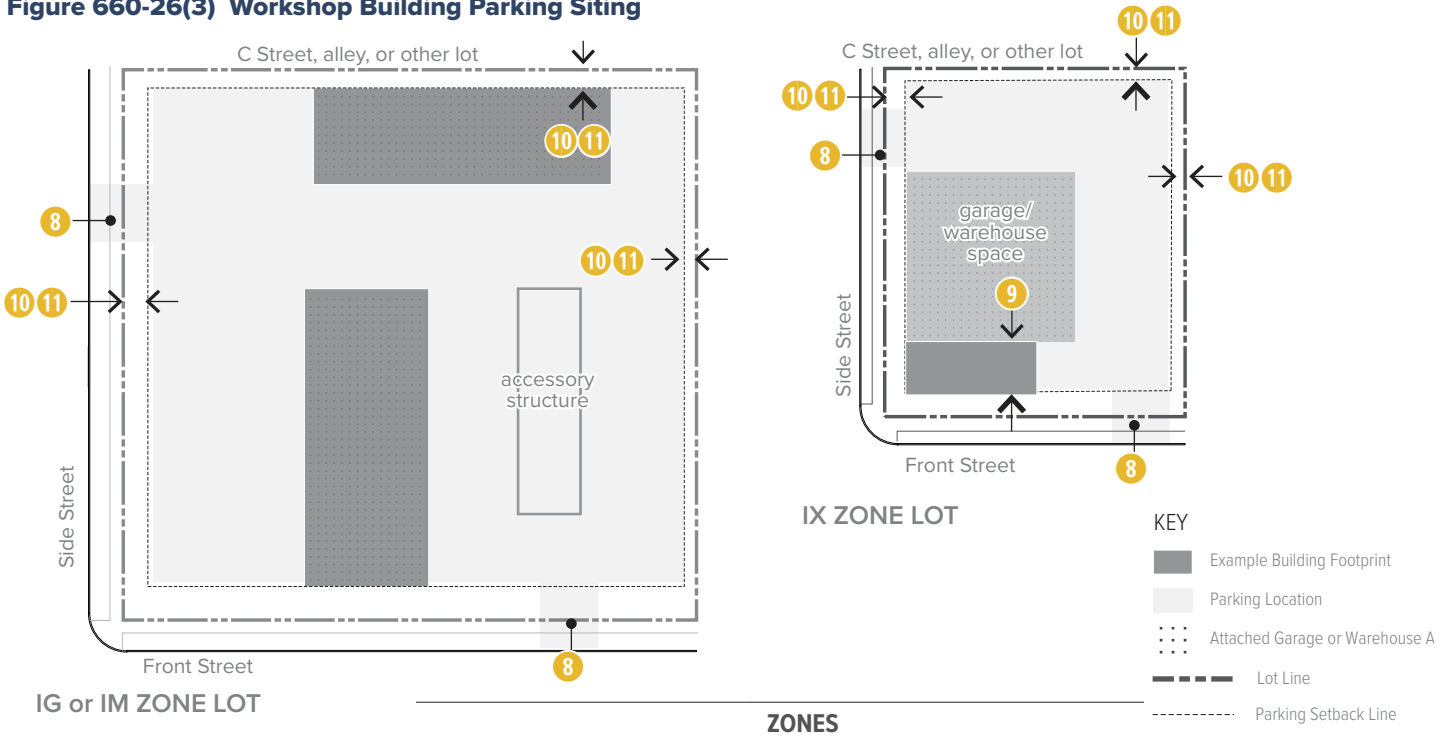

ZONES	IX, P1, P2	IG, IM	Additional/References
-------	------------	--------	-----------------------

660-26.E. PARKING & ACCESSORY STRUCTURES. See Figure 660-26(3)

8	Parking & Driveway Access	1 per 120 ft. of street frontage; or 2 on front street if no C street, improved alley, or side street abuts the property	See Article 8 for parking.
9	Allowed Garage Door Location	Any facade	Any facade
10	Surface Parking & Loading Location	Any yard	Any yard
	Front, Side-Street, Side & Rear Setback	5 ft. min., 15 ft. min. abutting to N zone	See 660-73 for landscape buffer adjacent to N zones.
11	Accessory Structure Location	Rear, side yard	Rear, side yard
	Street Setback	No closer to lot line than principal building	same as building setback
	Side & Rear Setback	5 ft. min., 15 ft. min. abutting to N zone	

KEY ACCESSORY STRUCTURES			KEY: ● = Allowed ○ = Requires Special Exception - = Not Allowed
Structure Type	IX, P1, P2	IG, IM	
Outbuildings	●	●	
Drive-Through Facilities	-	-	
Fuel Pumps	●	●, accessory to use only	
Outdoor Storage	●	●	
Parking Structure	●	●	

Figure 660-26(4) Workshop Building Height

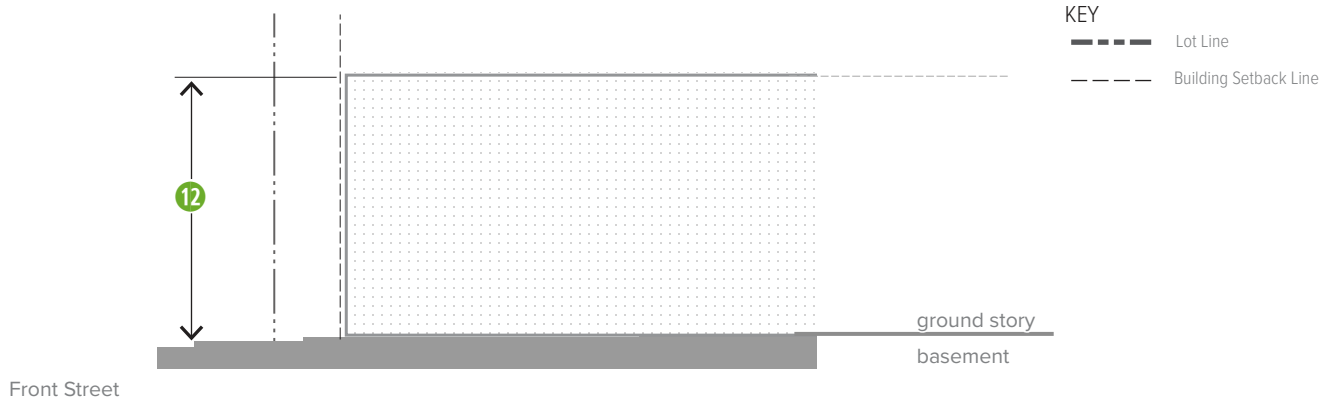
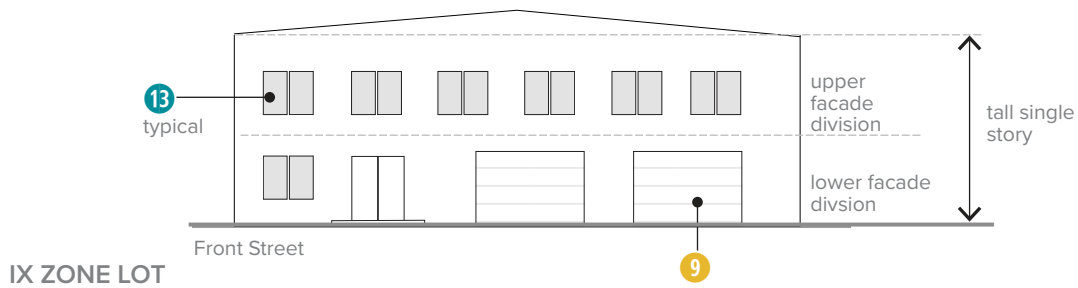

Figure 660-26(5) Workshop Building Facades



		ZONES		
		IX, P1, P2	IG, IM	Additional/References
660-26.F. HEIGHT. See Figure 660-26(4)				
12	Height	50 ft. max.	50 ft. max.; See 660-26.H for additional height on larger parcels	See 660-126.M for measuring height.
660-26.G. FRONT & SIDE-STREET FACADES. Figure 660-26(5)				
13	Transparency: Front Facade	20% min.	–	Measured per story. See 660-126.N for measuring transparency.
	No bay nor 15-ft.wide section of any story may be without transparency, except garage door bays		–	
	See 660-126.N (5) for tall story transparency requirements on tall stories over 18 ft. in height		–	

660-26.H SUPPLEMENTAL WORKSHOP BUILDING REGULATIONS

- (1) Additional Height.** On lots 15 acres or larger in area, the maximum height of the building may be increased through a special exception approval, provided the following:

 - (a) Other Zone Setback.** Any portion of the building that exceeds 50 feet in height must be set back from any other zone other than IX, IG, or IM a distance of 2 times the height of that portion of the building. For example, where a building has portions with heights of 75 feet and 100 feet, the portion that is 75 feet high must be set back a minimum of 150 feet from the adjacent zone and the portion that is 100 feet high must be set back 200 feet from the adjacent zone.
 - (b) Street Setback.** Additionally, the portion of the building with increased height must be set back a minimum of 50 feet from any street frontage with building frontage along the street no taller than 50 feet in height.

[page intentionally blank]

660-27 Civic Building

660-27.A DESCRIPTION AND INTENT

The Civic building is the most flexible building type, but is limited to buildings with specific large indoor or outdoor entertainment uses or civic and institutional uses. This building type is intended to allow distinctive buildings within the urban fabric, set back within a landscape setting or designed as unique, iconic structures.

A front entrance and multiple windows on the street promote walking to the buildings, while parking is located on the side or in the rear.

660-27.B ILLUSTRATIVE IMAGES

The images shown in [Figure 660-27\(1\)](#) are intended to illustrate the general character of the building type. The buildings and sites in each image may not fulfill all of the building type regulations.

660-27.C BUILDING REGULATIONS

The following tables and illustrations regulate this specific building type. See [660-12](#) for general regulations for all building types. See [Article 13](#) for definitions and measuring table regulations.

LINK	SUBSECTION
660-27.D	Building Siting
660-27.E	Parking & Accessory Structures
660-27.F	Uses
660-27.G	Height
660-27.H	Roofs
660-27.I	Front & Side-Street Facades
660-27.J	Supplemental Regulations



Figure 660-27(1) Civic Building Type Examples

Figure 660-27(2) Civic Building Siting

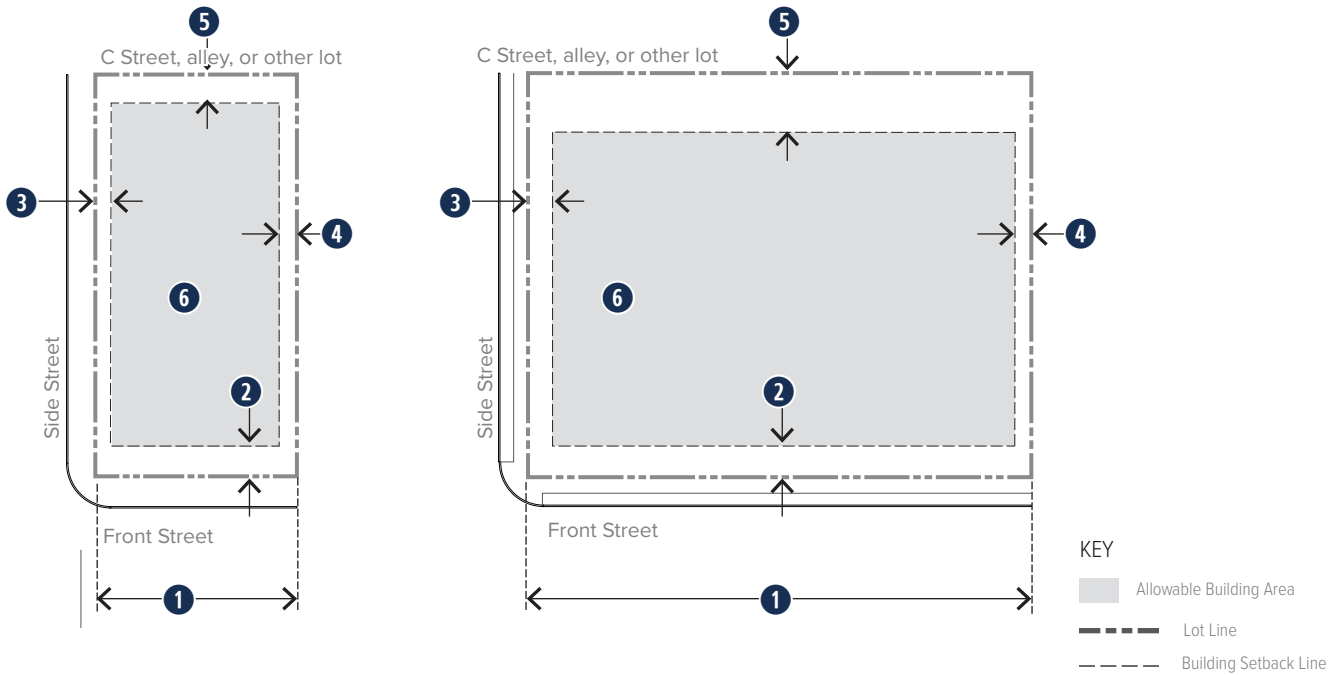

ZONES

	MX-D, GX-D, GX-C, GX-N	P1, P2	Additional/References
660-27.D. BUILDING SITING. See Figure 660-27(2)			
	Multiple Principal Buildings	Not allowed	Allowed
1	Lot Width	50 ft. min.	50 ft. min.
	Lot Frontage	A or B street. See 660-12.J for front street designation regulations.	
	Front Streetwall	No reqmt.	No reqmt.
2	Front Setback	10 ft. min.	10 ft. min.
3	Side-Street Setback	5 ft. min.	5 ft. min.
4	Side Setback Space between Buildings	5 ft. min. 10 ft. min.	5 ft. min. 12 ft. min.
5	Rear Setback	0 ft. at improved alley or C street; 10 ft. min.	10 ft. min.
6	Building Coverage	90% max.	90% max.
			Front-yard averaging may apply per 660-126.G . Minimum streetscape area required per 660-12.L .
			See 660-73 for landscape buffer adjacent to N zones.
			See 660-126.I for measuring building coverage.

Figure 660-27(3) Civic Building Parking Siting

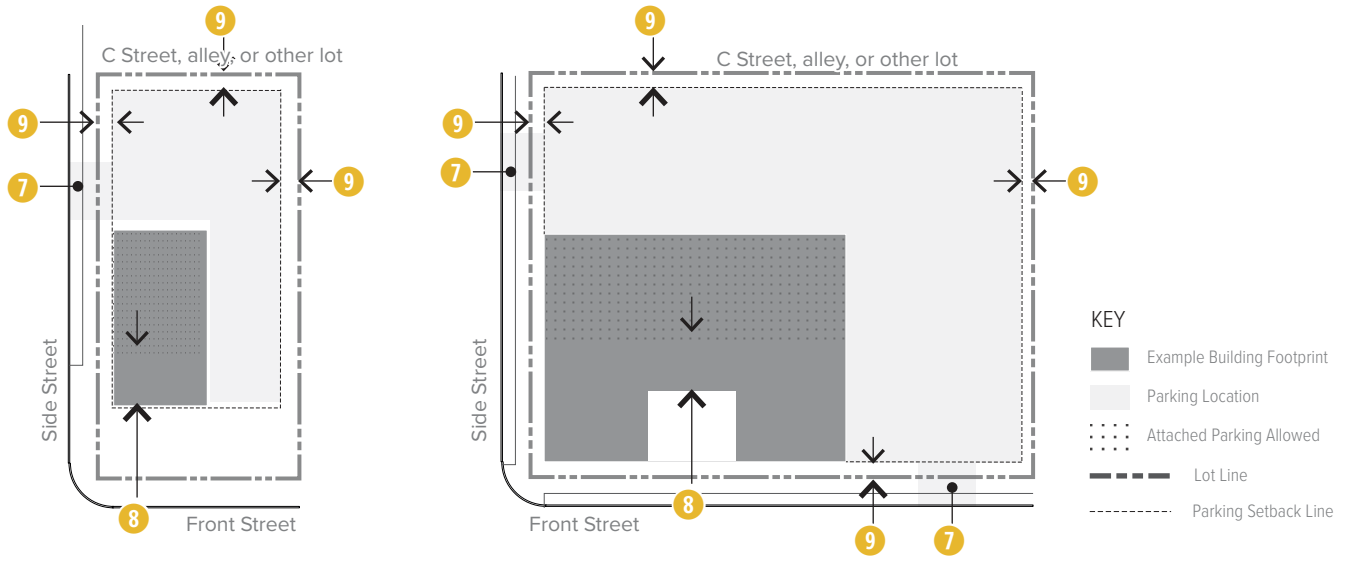

ZONES

MX-D, GX-D, GX-C,
GX-N

P1, P2

Additional/References

660-27.E. PARKING & ACCESSORY STRUCTURES. See Figure 660-27(3)

	MX-D, GX-D, GX-C, GX-N	P1, P2	Additional/References
7 Parking & Driveway Access	Driveway access is allowed per 660-12.K.		See Article 8 for parking.
8 Attached Garage Setback Allowed Garage Door Location	20 ft. min. behind front facade, located in rear of building B or C street facade, rear facade, interior side facade		
9 Surface Parking Location	Rear, limited side yard, internal		See 660-126.K for allowed limited side-yard parking layout.
Front & Side-Street Setback	No closer to lot line than principal building		
Side & Rear Setback	3 ft. min.	3 ft. min.	
10 Accessory Structure Location	Rear yard	Rear yard	See Article 5 for accessory structures.
Side-Street Setback	No closer to lot line than principal building		
Side & Rear Setback	3 ft. min.	3 ft. min.	

KEY ACCESSORY STRUCTURES

Accessory Structure	MX-D, GX-D, GX-C, GX-N	P1, P2	KEY:
Outbuildings	●	●	● = Allowed
Drive-Through Facilities	-	-	○ = Requires Special Exception
Fuel Pumps	-	-	- = Not Allowed
Outdoor Storage	-	○	
Parking Structure	●	●	

660-27.F. USES.

Allowed Uses	Use of the Civic building is limited only to the large, indoor spectator/participant entertainment use category, the outdoor spectator/participant entertainment use category, and any civic and institutional category uses allowed in the zone per Article 4. See 660-27.J for household living uses with historic designation.	See Article 4 for allowed uses.

Figure 660-27(4) Civic Building Height and Roofs

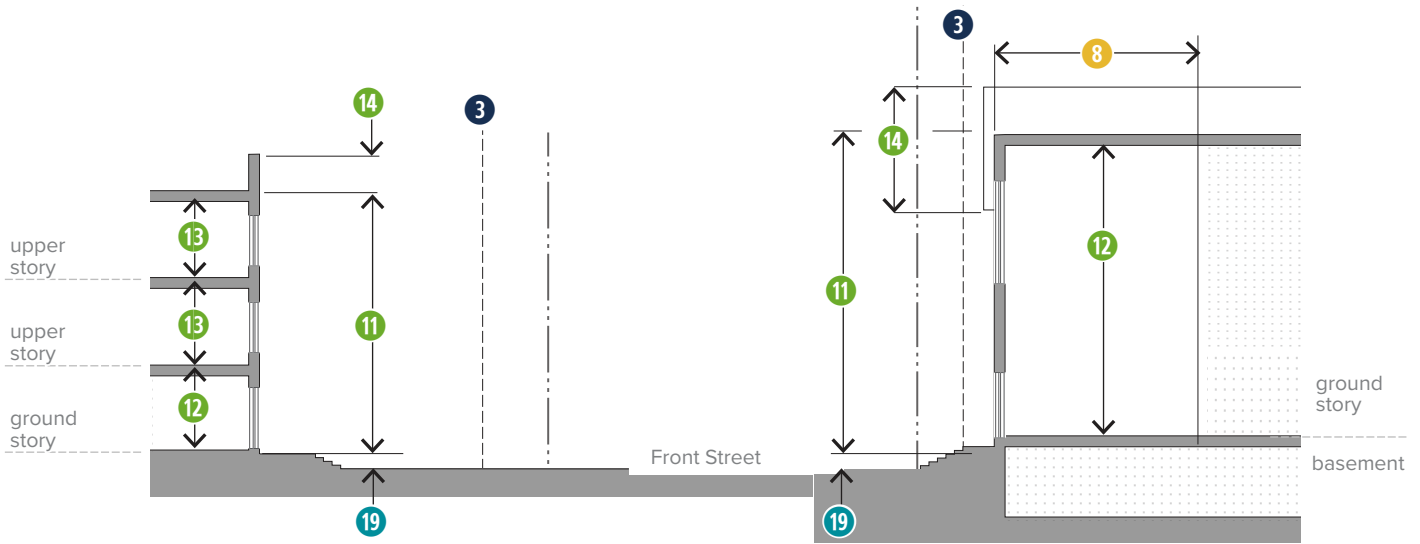

		ZONES		
		MX-D, GX-D, GX-C, GX-N	P1, P2	Additional/References
660-27.G. HEIGHT. See Figure 660-27(4)				
11	Height	3 stories max.		See 660-126.M for measuring height.
12	Ground Story Height	10 ft. min. 24 ft. max., additional height may be approved through the special exception process		Measured floor-to-floor.
13	All Other Stories Height	9 ft. min. 14 ft. max.	9 ft. min. 14 ft. max.	
660-27.H. ROOFS. See Figure 660-27(4)				
14	Allowed Roof Types	Any		See 660-55 for roof types and towers.
15	Tower	Allowed	Allowed	

Figure 660-27(5) Civic Building Facades

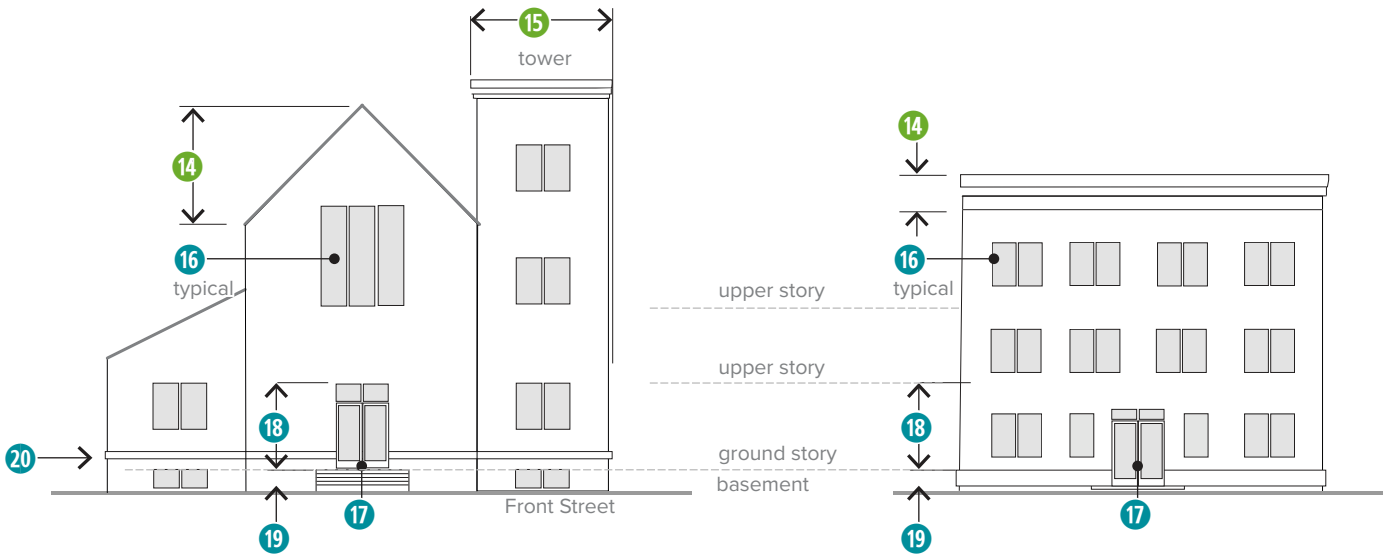

ZONES

MX-D, GX-D, GX-C,
GX-N

P1, P2

Additional/References

660-27.I. FRONT & SIDE-STREET FACADES. Figure 660-27(5)

	MX-D, GX-D, GX-C, GX-N	P1, P2	Additional/References
16 Transparency: Front Facades Side-Street Facades	10% min. 10% min.	10% min. 10% min.	Measured per story, including any half stories, visible basements, or towers with full-floor height. See 660-126.N for measuring transparency.
	Lower transparency may be approved through the special exception process		
	On front facades, no bay nor 15-ft.-wide section of any story may be without transparency		
17 Building Entrances Location	One per every 100 ft.	One per every 100 ft. of front facade of front facade	See 660-126.O for measuring building entrance location.
18 Allowed Entrance Types	Any	Any	See 660-57 for entrance types.
19 Ground-Floor Elevation	Less than 30 in. above grade or between 30 in. and 48 in. with a visible basement		See 660-128 for definition of visible basement.
20 Horizontal Divisions with Shadow Lines	Within 3 ft. of the top of any story between the basement and 3rd story		
Vertical Divisions with Shadow Lines	-	-	

660-27.J SUPPLEMENTAL CIVIC BUILDING REGULATIONS

(1) Household Living Uses with Historic Designation.

When the Civic building is eligible for listing on the National Register, household living uses (per 660-30.A) may be allowed as follows:

- (a) See Table 660-5 for uses allowed in the subject zone.
- (b) Special exception approval is required when household living is not allowed within the zone of the subject building.
- (c) See Table 660-3 for minimum dwelling unit sizes.
- (d) The number of dwelling units allowed in the Civic Building may not exceed the maximum number allowed for any building type permitted in the subject zone. If multiple building types are allowed in the zone, the building type that allows the most dwelling units shall serve as the maximum.
- (e) In zones that do not allow household living uses, the number of dwelling units allowed in the Civic Building may not exceed the maximum number allowed for any building type permitted in an abutting zone. If the lot occupied by the Civic Building abuts multiple zones, the abutting zone that permits the most dwelling units shall serve as the maximum.

DRAFT

ARTICLE 4. USES

660-28 Allowed Uses 4-2
660-29 Use Classification System 4-2
660-30 Residential Group 4-6
660-31 Commercial Group 4-10
660-32 Manufacturing & Industry Group 4-18
660-33 Civic & Institutional Group 4-21
660-34 Other Principal Uses 4-24

660-28 Allowed Uses

660-28.A USE TABLE

Table 660-5 identifies the principal uses allowed within the zones established by this zoning ordinance.

660-28.B INTERPRETING THE USE TABLE

- (1) **Use Classification System.** Uses are listed in the first column of the use tables. These uses are further described in the remaining sections of this article.
- (2) **Permitted.** Uses identified with a “●” symbol are permitted as-of-right in the subject zone.
- (3) **Special Exception.** Uses identified with a “○” symbol are allowed only if reviewed and approved in accordance with the special exception procedures of 660-110.
- (4) **Permitted Above or Below Ground Story or Rear of Ground Story.** Uses identified with a “◐” symbol are permitted as-of-right in the subject zone but only when located above or below the ground story or in the rear of the ground story at least 20 feet behind the front facade.
- (5) **Permitted in Limited Area.** Uses identified with a “◑” symbol are permitted as-of-right in the subject zone if such use occupies a lot with frontage on a mixed-use corridor (as defined in 660-139). If the subject lot does not have frontage on a mixed-use corridor, such use is limited to the ground story of the subject building and may not occupy more than 25% of the building's ground story area (i.e., building footprint). This 25% building footprint limitation may be waived if approved in accordance with the special exception procedures of 660-110.
- (6) **Special Exception on Mixed-Use Corridor.** Uses identified with a “◒” symbol are allowed only on lots with frontage on a mixed-use corridor and only if reviewed and approved in accordance with the special exception procedures of 660-110.
- (7) **Prohibited.** Uses identified with a “—” are expressly prohibited in the subject zone. Uses that are not listed in the table and that cannot be reasonably interpreted to fall within any defined use category or subcategory (as stated in 660-29.D) are also prohibited.
- (8) **Accessory Uses.** Many customary accessory uses and structures are allowed in conjunction with principal uses. The use table does not list these accessory uses. See Article 5 for regulations.

660-29 Use Classification System

This section establishes and describes the use classification system used to categorize principal uses.

660-29.A USE GROUPS

This zoning ordinance classifies principal land uses into 5 major groupings. These are referred to as “use groups.” The use groups are as follows:

- (1) Residential (see 660-30).
- (2) Commercial (see 660-31).
- (3) Manufacturing & Industry (see 660-32).
- (4) Civic & Institutional (see 660-33).
- (5) Other Principal Uses (see 660-34).

660-29.B USE CATEGORIES

Each use group is further divided into more specific categories. Use categories classify principal land uses and activities based on common functional, product or physical characteristics, such as the type and amount of activity, the type of customers or residents, how goods or services are sold or delivered, or relevant building or site conditions.

660-29.C USE SUBCATEGORIES

Some use categories are further broken down to identify specific subcategories of uses.

660-29.D CLASSIFICATION OF USES

- (1) The zoning officer is authorized to classify individual uses on the basis of the use group, category, and subcategory descriptions of this article.
- (2) When a use cannot be reasonably classified into a use group, category, or subcategory, or appears to fit multiple groups, categories, or subcategories, the zoning officer is authorized to assign the use to the most similar and thus most appropriate group, category, or subcategory based on the actual or projected characteristics of the principal use or activity in relationship to the use group, category, or subcategory descriptions. In making such determinations, the zoning officer must consider:
 - (a) The types of activities that will occur with the use;
 - (b) The types of equipment and processes to be used;
 - (c) The existence, number, and frequency of residents, customers or employees;
 - (d) Parking demands associated with the use; and
 - (e) Other relevant factors.
- (3) If a use can reasonably be classified in multiple groups, categories, or subcategories, the zoning officer is authorized to categorize each use in the category or subcategory that provides the most exact, narrowest and appropriate fit.
- (4) Appeals of the zoning officer's use classification determination may be taken to the zoning hearing board in accordance with the procedures of 660-116.

Table 660-5. Use Table

	ZONES																	Description & Add'l Regulations	
	MX-				GX-			N					I			P			
	D	C	S	N	D	C	N	NX	N1	N2	N3	N4	N5	IX	IG	IM	P1		P2
RESIDENTIAL (See 660-30)																			
Household Living																			
Adaptive Reuse	○	○	○	○	○	○	○	-	-	-	-	-	-	-	-	-	-	-	660-30.A
Other Household Living	◐	◐	◐	◐	●	●	●	●	●	●	●	●	●	-	-	-	-	-	660-30.A
Number of Allowed Units per Building	Regulated by building type (see Article 3)																		
Student Residence	Regulated only within the Student Residence Overlay (SRO) zone (see 660-08.D)																	660-30.B	
Group Home																			
Small	-	-	-	-	○	○	○	○	○	○	○	○	○	-	-	-	-	-	660-30.C
Large	-	-	-	-	○	○	○	○	○	-	-	-	-	-	-	-	-	-	660-30.C
Congregate Living																			
Dormitory	◐	◐	◐	-	●	◐	-	-	-	-	-	-	-	-	-	-	-	●	660-30.D
Drug or Alcohol Rehabilitation Facility	-	-	-	-	-	◐	-	-	-	-	-	-	-	-	-	-	-	○	660-30.D
Fraternity or Sorority	-	-	-	-	-	◐	-	-	-	-	-	-	-	-	-	-	-	●	660-30.D
Halfway House	-	-	-	-	-	◐	-	-	-	-	-	-	-	-	-	-	-	○	660-30.D
Nursing Home	-	◐	◐	○	-	○	○	○	○	-	-	-	-	-	-	-	-	●	660-30.D
Personal Care Home	-	◐	◐	○	-	○	○	○	○	-	-	-	-	-	-	-	-	●	660-30.D
Rooming or Boarding House	-	-	-	-	-	◐	-	-	-	-	-	-	-	-	-	-	-	○	660-30.D
Temporary Shelters	-	-	-	-	-	◐	-	-	-	-	-	-	-	-	-	-	-	○	660-30.D
Other Congregate Living Arrangements	-	-	-	-	-	◐	-	-	-	-	-	-	-	-	-	-	-	○	660-30.D
COMMERCIAL (See 660-31)																			
Adult Use	-	-	-	-	-	-	-	-	-	-	-	-	-	○	-	-	-	-	660-31.A
Animal Service																			
Indoor	●	●	●	◐	●	●	◐	-	-	-	-	-	-	●	●	●	-	-	660-31.B
Outdoor, Limited	◐	●	●	-	●	●	-	-	-	-	-	-	-	-	-	-	-	○	660-31.B
Outdoor, General	-	-	○	-	-	-	-	-	-	-	-	-	-	-	●	-	-	○	660-31.B
Child Care																			
Family Child Care Home	-	-	-	●	-	●	●	●	●	●	●	●	●	-	-	-	-	-	660-31.C
Group Child Care Home	-	-	-	-	●	●	●	-	○	○	○	○	-	-	-	-	-	-	660-31.C
Micro Child Care Center	◐	●	●	●	●	●	●	-	-	-	-	-	-	●	●	●	-	●	660-31.C
Child Care Center	◐	●	●	○	●	●	○	-	-	-	-	-	-	●	●	●	-	●	660-31.C
Consumer Service, Indoor																			
Art Gallery	●	●	●	●	●	●	●											○	
Business Support Service	◐	●	●	●	●	●	●	-	-	-	-	-	-	●	-	-	-	-	660-31.D
Maintenance & Repair Service	◐	●	●	●	●	●	●	-	-	-	-	-	-	●	●	●	-	-	660-31.D
Personal Improvement Service	●	●	●	●	●	●	●	-	-	-	-	-	-	●	-	-	-	-	660-31.D
Studio, Artist or Instructional Service	◐	●	●	●	●	●	●	-	-	-	-	-	-	●	-	-	-	○	660-31.D

Key (see 660-28.B): ● = permitted | ○ = special exception approval required | ◐ = permitted in upper stories or rear of ground story
 ◑ = permitted in limited area | ◒ = special exception on mixed-use corridor | - = prohibited

Table 660-5. Use Table

	ZONES																Description & Add'l Regulations		
	MX-				GX-			N					I			P			
	D	C	S	N	D	C	N	NX	N1	N2	N3	N4	N5	IX	IG	IM		P1	P2
Business Training	☉	●	●	●	●	●	●	-	-	-	-	-	-	●	●	●	-	-	660-31.D
Personal Credit Establishment	-	○	●	-	●	☉	-	-	-	-	-	-	-	-	-	-	-	-	660-31.D
Day Care Center, Adult	☉	●	●	○	●	●	○	-	-	-	-	-	-	●	☉	☉	-	●	660-31.E
Eating and Drinking Places																			
Bring-Your-Own-Bottle Establishment	●	☉	●	-	●	☉	-	-	-	-	-	-	-	-	-	-	-	-	660-31.F
Catering	☉	●	●	☉	-	☉	☉	-	-	-	-	-	-	●	☉	☉	-	-	660-31.F
Restaurant	●	●	●	☉	●	☉	☉	-	-	-	-	-	-	☉	-	-	-	☉	660-31.F
Tavern	●	☉	●	-	●	☉	-	-	-	-	-	-	-	-	-	-	-	-	660-31.F
Food Truck	○	○	○	-	○	○	-	-	-	-	-	-	-	-	-	-	-	-	660-31.F
Entertainment, Spectator/Participant																			
Betting Use	☉	○	○	-	○	-	-	-	-	-	-	-	-	-	-	-	-	-	660-31.G
Skills Game	☉	○	○	-	○	-	-	-	-	-	-	-	-	-	-	-	-	-	660-31.G
Indoor, Small	●	●	●	☉	●	☉	☉	-	-	-	-	-	-	-	-	-	-	●	660-31.G
Indoor, Large	●	-	●	-	-	-	-	-	-	-	-	-	-	-	-	-	-	●	660-31.G
Outdoor	-	-	●	-	-	-	-	-	-	-	-	-	-	-	-	-	-	●	660-31.G
Funeral & Mortuary Service	-	-	●	-	-	●	○	-	-	-	-	-	-	-	-	-	-	-	660-31.H
Lodging																			
B&B Inn	-	-	-	-	-	●	●	-	-	-	-	-	-	-	-	-	-	-	660-31.I
Hotel/Motel	●	●	●	-	●	●	-	-	-	-	-	-	-	-	-	-	-	-	660-31.I
Marina	-	-	-	-	-	●	-	-	-	-	-	-	-	-	-	-	●	-	660-31.J
Office																			
Admin., Business or Professional Office	☉	●	●	●	●	●	●	-	-	-	-	-	-	●	-	-	-	●	660-31.K
Medical Lab or Health-Related Service	☉	●	●	-	●	●	-	-	-	-	-	-	-	-	-	-	-	-	660-31.K
Financial Service	●	●	●	●	●	●	●	-	-	-	-	-	-	-	-	-	-	○	660-31.K
Service Office	☉	☉	●	-	●	☉	-	-	-	-	-	-	-	●	●	●	-	-	660-31.K
Walk-in Office	●	●	●	●	●	●	●	-	-	-	-	-	-	-	-	-	-	-	660-31.K
Retail Sales																			
Indoor	●	●	●	●	●	☉	☉	-	-	-	-	-	-	●	-	-	-	☉	660-31.L
Outdoor	-	○	○	-	-	○	-	-	-	-	-	-	-	○	-	-	-	-	660-31.L
Self-Service Storage	-	-	-	-	-	○	-	-	-	-	-	-	-	○	-	-	-	-	660-31.M
Vehicle Sales & Service																			
Personal Vehicle Repair & Maint., Minor	-	-	●	-	-	-	-	-	-	-	-	-	-	●	-	-	-	-	660-31.N
Personal Vehicle Repair & Maint., Major	-	-	-	-	-	-	-	-	-	-	-	-	-	●	●	●	-	-	660-31.N
Personal Vehicle Sales and Rentals	-	-	●	-	-	-	-	-	-	-	-	-	-	-	-	-	-	-	660-31.N
Fueling Station	-	-	●	-	-	-	-	-	-	-	-	-	-	●	-	-	-	-	660-31.N

Key (see 660-28.B): ● = permitted | ○ = special exception approval required | ☉ = permitted in upper stories or rear of ground story
 ☉ = permitted in limited area | ☉ = special exception on mixed-use corridor | - = prohibited

Table 660-5. Use Table

	ZONES																	Description & Add'l Regulations	
	MX-				GX-			N					I			P			
	D	C	S	N	D	C	N	NX	N1	N2	N3	N4	N5	IX	IG	IM	P1		P2
MANUFACTURING & INDUSTRY (See 660-32)																			
Artisan Manufacturing	●	●	●	○	●	●	○	-	-	-	-	-	-	●	●	●	-	●	660-32.A
Low-Impact Manufacturing	●	●	●	-	●	●	-	-	-	-	-	-	-	●	●	●	-	-	660-32.B
Moderate-Impact Manufacturing	-	-	-	-	-	-	-	-	-	-	-	-	-	-	●	●	-	-	660-32.C
High-Impact Industry	-	-	-	-	-	-	-	-	-	-	-	-	-	-	-	○	-	-	660-32.D
Industrial Service	-	-	-	-	-	-	-	-	-	-	-	-	-	-	●	●	-	-	660-32.E
Recycling Use																			
Recyclable Material Collection	-	-	-	-	-	-	-	-	-	-	-	-	-	-	●	●	-	-	660-32.F
Recyclable Material Processing	-	-	-	-	-	-	-	-	-	-	-	-	-	-	○	●	-	-	660-32.F
Warehousing & Distribution																			
Indoor, Up to 50,000 sq. ft. GFA	●	●	●	-	●	●	-	-	-	-	-	-	-	●	●	●	-	-	660-32.G
Indoor, More than 50,000 sq. ft. GFA	-	-	-	-	-	-	-	-	-	-	-	-	-	●	●	●	-	-	660-32.G
Outdoor, More than 50,000 sq. ft. (site area)	-	-	-	-	-	-	-	-	-	-	-	-	-	-	●	●	-	-	660-32.G
Outdoor, Principal Use	-	-	-	-	-	-	-	-	-	-	-	-	-	-	-	●	-	-	660-32.G
CIVIC & INSTITUTIONAL (See 660-33)																			
Cemetery	-	-	-	-	-	-	-	-	-	-	-	-	-	-	-	-	●	-	660-33.A
College or University	●	●	●	-	●	●	-	-	-	-	-	-	-	-	-	-	-	●	660-33.B
Community Assembly	●	●	●	○	●	●	○	-	-	-	-	-	-	-	-	-	-	●	660-33.C
Detention or Correctional Facility	-	-	-	-	-	-	-	-	-	-	-	-	-	-	-	-	-	○	660-33.D
Governmental Use	●	●	●	●	●	●	●	-	-	-	-	-	-	●	-	-	-	●	660-33.E
Hospital	-	●	●	-	-	○	-	-	-	-	-	-	-	-	-	-	-	●	660-33.F
Library or Cultural Exhibit	●	●	●	○	●	●	○	-	-	-	-	-	-	-	-	-	○	●	660-33.G
Parks and Open Space	●	●	●	●	●	●	●	●	●	●	●	●	●	●	●	●	●	●	660-33.H
School	●	●	●	○	●	●	○	-	-	-	-	-	-	-	-	-	-	●	660-33.I
Transportation Facilities	-	-	●	-	●	-	-	-	-	-	-	-	-	-	●	●	-	●	660-33.J
Infrastructure & Utilities																			
Minor	●	●	●	●	●	●	●	●	●	●	●	●	●	●	●	●	●	●	660-33.K
Major	○	○	○	○	○	○	○	○	○	○	○	○	○	○	●	●	●	○	660-33.L
OTHER PRINCIPAL USES (See 660-34)																			
Agriculture	●	●	●	●	●	●	●	●	●	●	●	●	●	●	●	●	●	●	660-34.A
Communication, Commercial																			
Antenna	●	●	●	●	●	●	●	●	●	●	●	●	●	●	●	●	●	●	660-34.B
Tower	-	-	○	-	-	-	-	-	-	-	-	-	-	○	●	●	○	○	660-34.B
Live/Work Unit	●	●	●	●	●	●	-	○	○	-	-	-	-	-	-	-	-	-	660-34.C
Off-Street Parking	○	○	○	○	○	○	○	○	○	-	-	-	○	-	-	○	○	-	660-34.D

Key (see 660-28.B): ● = permitted | ○ = special exception approval required | ● = permitted in upper stories or rear of ground story

● = permitted in limited area | ● = special exception on mixed-use corridor | - = prohibited

660-30 Residential Group

The residential use group includes uses that provide living accommodations for one or more persons.

660-30.A HOUSEHOLD LIVING

(1) Use Category Description. The household living use category is characterized by a single household occupying a dwelling unit that is self-contained, with facilities for cooking, eating, sleeping, and hygiene. Tenancy is on a month-to-month or longer basis. Examples of household living uses include living in houses, residential buildings containing multiple dwelling units, mixed-use buildings, and other buildings containing self-contained dwelling units.

(2) Subcategories. The household living use category includes the following subcategories:

(a) Adaptive Reuse. The conversion of 65% or more of the gross floor area of a principal building formerly occupied by nonresidential uses (without any principal residential use) into dwelling units. Conversion of a principal building with a floor area of less than 5,000 square feet into dwelling units is not classified as adaptive reuse.

(b) Other Household Living. Household living uses that do not meet the definition of adaptive reuse (660-30.A(2)(a)).

(3) Supplemental Use Regulations. Household living uses are subject to the following supplemental use regulations:

(a) General. The following general supplemental use regulations apply to all household living uses unless otherwise expressly stated.

- [1] The number of dwelling units allowed on a lot varies by building type and zone classification. See the building type regulations of Article 3 for applicable regulations.
- [2] Manufactured (Mobile) Home Parks are permitted only in the NX zones and require special exception approval. See 660-13.D for additional regulations.
- [3] Unless otherwise expressly stated elsewhere in this zoning ordinance (e.g., affordable housing units, accessory dwelling units, and tiny home villages), all dwelling units must comply with the general minimum floor area requirements of Table 660-3.

Table 660-3. General Minimum Floor Area Requirements

DWELLING UNIT TYPE	MINIMUM FLOOR AREA (SQ. FT.)
Efficiency	500
1-bedroom	500
2-bedroom	700
3+-bedroom	900

(b) Adaptive Reuse. The following supplemental use regulations apply to all adaptive reuse projects unless otherwise expressly stated.

- [1] **Planning Commission Review.** Applications for approval of adaptive reuse projects must be referred to the planning commission for review and comment. In order for comments to be considered as part of the special exception review process, the planning commission must submit any comments on the application within 45 days of the date that the application was referred to them.
- [2] **MX Zones.** Adaptive reuse in MX zones may be approved only when located above the ground story or in the rear of the ground story, at least 20 feet behind the front facade.
- [3] **Street Facades.** All front and side-street facades must be brought into compliance with transparency and building entrance requirements of Article 3 that apply to the subject building type.
- [4] **Facade Materials.** The facade material requirements in 660-58 apply to all A and B street, and other front facades of adaptive reuse buildings.
- [5] **Site Design.** The site design regulations of Article 7 apply to adaptive reuse projects.
- [6] **Parking.** Required parking (see 660-79) must be sited in accordance with the regulations that apply to the subject building type.
- [7] **Historic Elements.** If compliance with the adaptive reuse regulations of this section would require the removal of original historic building elements such removal may be authorized in accordance with the special exception procedures of 660-110, provided that all applicable historical architectural review board (HARB) and historic building demolition overlay (HBDO) regulations are met.
- [8] **Other Relief.** Requests for relief from strict compliance with the adaptive reuse

supplemental use regulations established in 660-30.A(3)(b)[3], [4], [5], and [6] may be approved in accordance with the special exception procedures of 660-110. All other requests for relief from strict compliance with the adaptive reuse supplemental use regulations of 660-30.A(3)(b) must be processed as variances in accordance with 660-111.

(c) Affordable Housing. The following supplemental use regulations apply to all affordable housing developments unless otherwise expressly stated.

- [1] For purposes of these regulations "affordable housing" means:
 - [i] A principal building occupied by 4 or fewer dwelling units in which 100% of dwelling units are set aside for and restricted for a minimum of 20 years to occupancy by households earning no more than 80% of the area median income (AMI) as defined by the U.S. Department of Housing and Urban Development; or
 - [ii] A principal building occupied by more than 4 dwelling units in which at least 20% of the dwelling units are set aside for and restricted for a minimum of 20 years to occupancy by households earning no more than 80% of the area median income (AMI), as defined by the U.S. Department of Housing and Urban Development.
- [2] To ensure compliance with applicable affordability terms, the project must be funded through city, state, or federal grant programs with income restrictions or be subject to income verification through the low-income housing tax credits (LIHTC) program. The zoning officer is also authorized to accept a deed restriction, covenant or other government-approved legal agreement as a guarantee of compliance with affordability terms and income limits.
- [3] The zoning officer is authorized to establish tracking and monitoring requirements for applicants and affected departments to ensure continuing compliance with affordability requirements.
- [4] Affordable housing developments that meet the definition of "adaptive reuse" are exempt from the adaptive reuse supplemental use regulations established in 660-30.A(3)(b)[3], [4], and [5], except that they are not exempt from

the transparency requirements of Article 3 for the subject building type.

- [5] Affordable housing developments are eligible for additional building height allowance in accordance with 660-16.J and 660-14.J.
- [6] Affordable housing developments are eligible for parking reductions in accordance with (a).
 - [i] Affordable housing developments are subject to the alternative minimum floor area requirements of Table 660-4.

Table 660-4. Alternative Minimum Floor Area Requirements

DWELLING UNIT TYPE	MINIMUM FLOOR AREA (SQ. FT.)
Efficiency	400
1-bedroom	400
2-bedroom	550
3-bedroom	750
4+-bedroom	900

[7] Affordable housing developments must comply with Property Rehabilitation and Maintenance Code regulations (Chapter 455).

660-30.B STUDENT RESIDENCE

- (1) Use Category Description.** The student residence use category is characterized by a living arrangement consisting of 3 or 4 unrelated full-time or part-time students living in a dwelling unit in the Student Residence Overlay zone as a single housekeeping unit and who:
 - (a)** Attend undergraduate colleges or universities;
 - (b)** Attend graduate programs at colleges or universities;
 - (c)** Are on a semester or summer break from studies at colleges or universities; or
 - (d)** Any combination of such persons.
- (2) Exceptions.** Dormitories, fraternities, and sororities are not considered student residences. Student residence living arrangements are only regulated within the Student Residence Overlay zone. Three or 4 unrelated students living together outside a Student Residence Overlay zone are classified and regulated as a household living use.
- (3) Supplemental Use Regulations.** Student residences within the Student Residence Overlay (SRO) zone are subject to the following supplemental use regulations:

- (a) Student residences are permitted only in detached residential structures of 2 or more dwelling units. New student residences may not be located in structures of 2 or more dwelling units that were created through the conversion of a house occupied by a single dwelling or through the merger of adjoining properties that occurred after October 26, 1997.
- (b) The owner of a structure in which a lawful nonconforming student residence was in existence as of October 26, 1997 and properly registered same with the zoning office as required by Ordinance No. 13607, may continue the use provided that the registration is renewed annually. In support of the application, the property owner must produce documentation in support of the student residence living arrangement.
- (c) The residents of a student residence must live in a dwelling unit as a single housekeeping unit, doing their cooking on the premises.
- (d) See also the SRO zone regulations of 660-08.D.

660-30.C GROUP HOME

- (1) **Use Category Description.** The group home use category is characterized by residential occupancy of all or a portion of a dwelling unit by persons with disabilities, including individuals in recovery from substance use disorder or alcohol addiction, and attendant staff, living together and functioning as a single housekeeping unit under a common housekeeping management plan based upon an intentionally structured relationship providing organization and stability. Does not include drug and alcohol rehabilitation facilities, or adult prerelease correctional facilities such as work release, halfway houses, or similar uses.
- (2) **Subcategories.** The group home use category includes the following subcategories:
 - (a) **Small Group Home.** A group home with 5 or 6 residents, not including staff. Group homes with fewer than 5 residents are classified and regulated as a household living use.
 - (b) **Large Group Home.** A group home with 7 to 12 residents, not including staff. Facilities with more than 12 residents are classified in the "Congregate Living" use category.
- (3) **Exceptions.** Group homes with fewer than 5 residents are classified and regulated as a household living use. Residents of a group home are limited to individuals with physical or mental impairments that substantially limit one or more of their major life activities, as further

defined and regulated by the *Americans with Disabilities Act* and the federal *Fair Housing Amendments Act*.

- (4) **Supplemental Use Regulations.** All group homes (small and large) are subject to the following supplemental use regulations:
 - (a) A written narrative must be submitted describing the purpose and general operation of the proposed facility, including the number of residents, staff, level of supervision, and anticipated parking demand.
 - (b) Group homes located in residential neighborhoods must be indistinguishable from the exterior of other residential dwellings in the immediate neighborhood. However, improvements required by code for access or exit from the building are not deemed incompatible merely because surrounding buildings lack such facilities.
 - (c) Any counseling or other services provided must be solely for the benefit of residents of the group home.
 - (d) The group home must obtain all required licenses and permits from applicable state, county or city agencies before commencement of operations.
 - (e) The group home may not generate traffic greater in volume or different in nature than would normally occur in the neighborhood in which it is proposed to be located.
 - (f) The facility may not be located within 1,000 feet of another group home, drug or alcohol rehabilitation facility, temporary shelter, or halfway house, measured in a straight line between property lines.
 - (g) Off-street parking must be provided at the rate of at least one space per staff member plus any additional spaces stipulated by the zoning hearing board based on anticipated parking demand at the group home.
 - (h) All group homes must comply with applicable building, property maintenance, and fire codes.

660-30.D CONGREGATE LIVING

- (1) **Use Category Description.** The congregate living use category is characterized by residential occupancy of a structure by persons who do not qualify as a household, a student residence, or a group home. Residents of a congregate living use may share sleeping units, and may have shared cooking, bathroom and common areas, or some combination of personal and shared facilities. Residents of a congregate living use may or may not receive services, care, or supervision of any type as a condition of residency. Tenancy is typically arranged on a month-to-month or longer basis.

(2) **Subcategories.** The congregate living use category includes the following subcategories:

- (a) **Dormitory.** A building or portion of a building containing living quarters for 5 or more students, staff or members of a college, university, primary or secondary boarding school, theological school, hospital, religious order or comparable organization, provided that such building is either owned or managed by such organization and contains not more than one cooking and eating area.
- (b) **Drug or Alcohol Rehabilitation Facility.** A facility that provides residentially based treatment and rehabilitation and/or out-patient services for not more than 30 persons.
- (c) **Fraternity or Sorority.** A building designed or arranged for occupancy by an incorporated nonprofit organization of full-time students of an accredited college or university.
- (d) **Halfway House.** A residential facility housing a maximum of 15 persons who receive therapy and counseling under the supervision and constraints of alternatives to imprisonment, such as, but not limited to, pre-release, work release, restitution, or probationary programs or a nonresidential facility involving similar types of programs.
- (e) **Nursing Home.** A facility licensed by the state as a nursing home and that provides residential accommodations and health care to persons who, by reason or advanced age, chronic illness, accident or infirmity, are unable to care for themselves, but not including drug or alcohol rehabilitation facilities.
- (f) **Personal Care Home.** A facility that provides, on a regular basis, housing, limited health care and specialized assistance with daily living to individuals who do not need care within a hospital or nursing home, but who need such care because of their advanced age, physical or developmental disability or illness. The term "personal care home" includes facilities licensed by the state as a personal care home or an assisted living facility.
- (g) **Rooming or Boarding House.** A building where lodging is provided with or without meals for 3 or more persons as their primary residence who are not members of the operator's household, and for compensation, whether direct or indirect.
- (h) **Temporary Shelter.** A facility operated by a nonprofit agency providing temporary housing, with or without meals, for persons experiencing

homelessness or those whom have been otherwise displaced from their usual residence.

- (i) **Other Congregate Living.** Uses that meet the definition of "congregate living" but that are not more specifically defined by any of the preceding use subcategory descriptions.

(3) **Supplemental Use Regulations**

(a) **Dormitories and Fraternities or Sororities.**

Dormitories, fraternities and sororities are subject to the following supplemental use regulations:

- [1] Dormitories are not allowed within the Student Residence Overlay zone except within a P2 zone.
- [2] Buildings must be set back at least 50 feet from the lot line of a dwelling located within an N zone.
- [3] If located off a college campus, buildings must contain at least 400 square feet of lot area for each student residing within the building.
- [4] All dormitories must be owned and/or operated by college, university, primary or secondary boarding school, theological school, hospital, religious order or comparable organization.
- [5] All fraternities and sororities are limited to housing students enrolled at or full-time employees of an accredited college or university and up to 2 live-in resident advisors.

(b) **Nursing Homes and Personal Care Homes.**

Nursing homes and personal care homes are subject to the following supplemental use regulations:

- [1] If special exception approval is required, a written narrative must be submitted describing the purpose and general operation of the proposed facility, including the number of residents, staff, and other relevant operational characteristics.
- [2] Buildings must be set back at least 30 feet from any MX-N, GX-N, or N-zoned lot.
- [3] The facility must obtain all required licenses or permits from applicable state, county or city agencies before the commencement of operations.

(c) **Rooming or Boarding Houses.**

Rooming and boarding houses are subject to the following supplemental use regulations:

- [1] Each rental unit must have a minimum floor area of 250 square feet for one occupant or 350 square feet for 2 occupants.
- [2] No more than 6 rental units are allowed on a single lot.
- [3] Rental units are limited to a maximum occupancy of 2 adults.
- [4] The building containing the rental units must be occupied by a resident manager.
- [5] The property owner must provide access to code enforcement officials to inspect the entire building for compliance with applicable city codes before issuance of a zoning permit.
- [6] Rooming and boarding houses must comply with Property Rehabilitation and Maintenance Code regulations (Chapter 455).

(d) Temporary Shelters, Halfway Houses, and Drug or Alcohol Rehabilitation Facilities. Temporary shelters, halfway houses, and drug or alcohol rehabilitation facilities are subject to the following supplemental use regulations:

- [1] A narrative must be submitted by the applicant describing the purpose and general operation of the proposed facility, including the number of residents, staff and level of supervision. The narrative must also describe any outpatient facilities to be provided on the site, and their anticipated level of service for the next 3 to 5 years.
- [2] The facility must obtain all required licenses or permits from applicable state, county or city agencies before the commencement of operations.
- [3] The facility may not be located within 1,000 feet of another drug or alcohol rehabilitation facility, temporary shelter, halfway house or group home, measured in a straight line between property lines.
- [4] All such uses must comply with applicable building, property maintenance, and fire codes.
- [5] Temporary shelters may include manufactured (mobile) homes and similar structures (e.g., tiny home villages), subject to compliance with all applicable regulations of 660-13.D.

660-31 Commercial Group

The commercial use group includes uses that provide a service or involve the selling, leasing or renting of merchandise to the general public.

660-31.A ADULT USE

- (1) Use Category Use Category Description.** The adult use category includes all adult book stores, adult motion picture theaters, and cabarets if such uses include "specified sexual activities" and/or "specified anatomical areas."
- (2) Subcategories.** Adult uses fall into the following subcategories:
 - (a) Adult Book Store.** An establishment having as a substantial or significant portion of its stock in trade, books, magazines, videotapes, computer software, photographs or other materials that are distinguished or characterized by their emphasis on matter depicting, describing or relating to "specified sexual activities" or "specified anatomical areas."
 - (b) Adult Motion Picture Theater.** An establishment used for presenting films, videotapes or similar images distinguished or characterized by an emphasis on matter depicting, describing or relating to "specified anatomical areas" or "specified sexual activities" for observation by patrons.
 - (c) Cabaret.** A club, bar, tavern, theater, hall or similar place that features topless female or bottomless male or female dancers, entertainers or employees, strippers, simulated sex acts, live or actual sex acts, or similar entertainers or entertainment.
- (3) Supplemental Use Regulations.** Adult uses are subject to the following supplemental use regulations:
 - (a) State Law.** All such uses must comply with all state laws which regulate adult live entertainment, obscenity and adult-oriented establishments and all other applicable state laws regulating or prohibiting "live sex acts."
 - (b) Required Separation.** It is unlawful to establish an adult use within 1,000 feet of any existing adult use or within 500 feet of any:
 - [1] Primary or secondary school;
 - [2] Residential dwelling unit;
 - [3] Child care facility;
 - [4] Place of worship; or
 - [5] Any MX-N, GX-N, or N zone.
 - (c) Special Exceptions.** The zoning hearing board may approve a special exception authorizing the establishment of an adult use only if the board makes the following findings, based on evidence provided by the applicant:
 - [1] That the proposed use will not adversely affect the desirability of existing dwellings in

the vicinity and will not be detrimental to the general character of the area;

- [2] That establishment of the proposed use will be compatible with any program of neighborhood revitalization; and
- [3] That all other applicable special exception approval criteria of this ordinance will be met.

- (d) **Other Ordinances.** Adult uses are subject to the regulations of Chapter 141 of the city code.
- (e) **Use Variances.** Variances that have the effect of allowing adult uses in zones in which such uses are not allowed pursuant to Table 660-5 are prohibited.
- (f) **Ownership.** As part of any application for an adult use, a notarized written statement must be submitted that lists the legal names and addresses of all individual persons with any ownership interest in the proposed use or in any corporation or company that owns the use, together with the legal name, address and daytime phone number of an on-site manager responsible to make sure that the use complies with state and city regulations on a daily basis. Any future changes in such persons must be submitted to the zoning officer within 7 calendar days after the change.
- (g) **Lot Area.** A minimum lot area of 20,000 square feet is required for the establishment or expansion of any adult use.
- (h) **Displays.** No pornographic or obscene material, signs or displays shall be visible to persons who are outside of the adult use establishment.
- (i) **Hours.** Any adult use approved after the adoption date of these adult use regulations shall be limited in its hours of operation to between 8 a.m. and midnight.

660-31.B ANIMAL SERVICE

- (1) **Use Category Description.** Establishments that provide services for the care of customary household pets, including boarding, training, grooming, and veterinary services. Includes pet day cares but excludes dog walking and similar pet care services not carried out at a fixed location.
- (2) **Subcategories.** The animal service use category includes the following subcategories:
 - (a) **Indoor.** Any animal service use that occurs entirely within a completely enclosed building.
 - (b) **Outdoor, Limited.** An animal service use that includes outdoor kennels or outdoor exercise areas

for no more than 12 household pets (e.g., doggy day care) with no overnight care or boarding services.

- (c) **Outdoor, General.** An animal service use that includes outdoor kennels or outdoor exercise areas for more than 12 household pets or that provides overnight care or boarding services.

660-31.C CHILD CARE

- (1) **Use Category Description.** Care, protection, and supervision for 4 or more children under 16 years of age away from their primary residence for less than 24 hours per day. The term does not include child care furnished in places of religious assembly, care in public or private schools before, during or after hours of instruction, or care given by relatives.
- (2) **Subcategories.** The child care use category includes three subcategories:
 - (a) **Family Child Care Home.** A dwelling unit in which child care is provided simultaneously for 4 to 6 children who are not relatives of the caregiver, where the principal use of the child care areas is as a residence.
 - (b) **Group Child Care Home.** A dwelling unit in which child care is provided simultaneously for 7 to 12 children who are not relatives of the caregiver, where the principal use of the child care areas is as a residence.
 - (c) **Micro Child Care Center.** An establishment that is not located within a dwelling unit that provides care, protection, and supervision for fewer than 7 children at any one time. Micro child care centers may be a principal or accessory use.
 - (d) **Child Care Center.** An establishment that is not located within a dwelling unit that provides care, protection and supervision for 7 or more children at any one time.

(3) Supplemental Use Regulations.

- (a) **Family Child Care Homes.** Family child care homes are subject to the following regulations:
 - [1] The family child care home must have a valid operational certificate issued by the Allentown Health Bureau and be registered by the State Department of Public Welfare prior to occupancy.
 - [2] Family child care homes are permitted only in dwellings within houses (House Types A, B, or C), twin houses, or rowhouses occupied by a single household.

- [3] The building in which the family child care home is located must be indistinguishable from the exterior of other residential dwellings in the immediate neighborhood, except that improvements required by permitting or licensing agencies are expressly permitted.
- [4] The operator-caregiver must be a permanent resident of the dwelling unit.
- [5] A family child care home may not employ persons who are not permanent residents of the dwelling unit, except as occasional substitutes.

(b) Group Child Care Homes. Group child care homes are subject to the following regulations:

- [1] A narrative setting forth the particulars of the operation, including number of staff persons, anticipated maximum number of children to be served, drop-off/loading areas, and staff parking must be submitted with the application.
- [2] The group child care home must have a valid operational certificate issued by the Allentown Health Bureau and be licensed by the State Department of Public Welfare prior to occupancy.
- [3] Group child care homes are permitted only in House Types A, B or C occupied by a single household.
- [4] The building in which the group child care home is located must be indistinguishable from the exterior of other residential dwellings in the immediate neighborhood, except that improvements required by permitting or licensing agencies are expressly permitted.
- [5] The operator-caregiver must be a permanent resident of the dwelling unit.
- [6] No more than 2 "outside" employees (i.e., individuals who are not permanent residents of the dwelling unit) are allowed, except that there may also be a non-resident substitute, on an occasional basis, for the operator-caregiver.

(c) Micro Child Care Centers. Micro child care centers are subject to the following supplemental use regulations:

- [1] The micro child care center must have a valid operational certificate issued by the Allentown Health Bureau and be licensed by the State Department of Public Welfare before occupancy.

- [2] Micro child care centers are permitted only in the following building types: storefront buildings, commercial centers, general buildings, small general buildings, and workshop buildings. They are expressly prohibited within dwelling units.

(d) Child Care Centers. Child care centers are subject to the following supplemental use regulations:

- [1] The minimum lot area requirement for a child care center is 3,000 square feet.
- [2] The applicant must submit a narrative describing the particulars of the operation including number of staff persons, licensed capacity, and hours of operation; and a site plan showing at least the location and dimensions of the building, (on- or off-site) outdoor play area, drop-off/loading areas, parking, and waste storage areas.
- [3] The child care center must have a valid operational certificate issued by the Allentown Health Bureau and be licensed by the State Department of Public Welfare before occupancy.
- [4] A child care center may not be within or physically attached to any structure containing one or more dwelling units.

660-31.D CONSUMER SERVICE, INDOOR

(1) Use Category Description. The indoor consumer service use category includes establishments that provide services to individuals or small businesses. Indoor consumer service uses are conducted from completely enclosed buildings, except for accessory activities that are customary and incidental to the principal use. See for regulations governing

(2) Subcategories. Examples of indoor consumer service uses include the following subcategories:

(a) Business Support Service. Establishments that provide personnel services, printing, copying, package (delivery) drop-off, photographic services or communication services to businesses or consumers. Examples include employment agencies, copy and print shops, delivery/courier service drop-off location for consumers, and photo developing labs.

(b) Maintenance & Repair Service. Establishments that provide maintenance, cleaning and repair services for consumer goods on a site other than that of the customer (i.e., customers bring goods to the site of the repair/maintenance business). Examples include laundry and dry cleaning pick-up shops,

laundromats, tailors, taxidermists, dressmakers, shoe repair, picture framing shops, gunsmiths, locksmiths, vacuum repair shops, electronics repair shops and similar establishments.

- (c) **Personal Improvement Service.** Establishments that provide personal grooming, cosmetic, or related services. Typical uses include barbers, hair and nail salons, tanning salons, day spas, and body art services.
- (d) **Studio, Artist or Instructional Service.** Establishments that provide instruction, training, or work space for individuals or groups involved in fine arts, music, dance, drama, personal fitness, or similar activities. Also includes dance studios, ballet academies, yoga studios, personal fitness training, martial arts instruction, tutoring, artist studios, and photography studios.
- (e) **Business Training.** Establishments and facilities, including classrooms, providing vocational, trade, business or professional training services in a completely enclosed building.
- (f) **Personal Credit Establishment.** Any one or more of the following:

- [1] **Check Cashing Establishment.** An establishment that is primarily engaged in the cashing of checks by individuals or the deferred deposit of personal checks whereby the check casher refrains from depositing a personal check written by a customer until a specific date; or the offering of a loan until a paycheck is received by the person receiving the loan. Check cashing establishments do not include any of the following: state or federally chartered banks or credit unions or retail sales establishments that cash checks for a fee not routinely exceeding one percent of the check amount as a service to its customers incidental to the retail principal use.
- [2] **Pawnbroker.** An establishment that is engaged to any extent in any of the following business or activities:
 - [i] The lending of money on the deposit or pledge of personal property;
 - [ii] The purchase of personal property either from an individual, another pawnbroker or any other business with an expressed or implied agreement or understanding to offer the property for sale to the public, and if that sale is unsuccessful, then to sell it back to the previous owner at a

subsequent time at a stipulated price or negotiated price;

- [iii] The purchase of precious metals with the intent to melt down, provided that such activity is not clearly incidental to the principal use of the establishment; or
- [iv] The lending of money upon personal property, goods, wares, or merchandise pledge, stored or deposited as collateral security.

[3] **Payday Lender.** Any person or entity that is substantially in the business of negotiating, arranging, aiding, or assisting a consumer in procuring payday loans.

(3) Supplemental Use Regulations

(a) Late-Night Operations.

- [1] Special exception approval is required for all indoor consumer service uses that are proposed to be open to the public during any hours between 2:00 a.m. and 6:00 a.m., provided that this requirement does not apply in MX-D and GX-D zones. Additionally, special exception approval is required for all indoor consumer service uses in MX-N and GX-N zones that are proposed to be open to the public during any hours between 10:00 p.m. and 6:00 a.m.
- [2] In considering the special exception, the zoning hearing board must consider whether the late-night hours are likely to create nuisances and incompatibilities with nearby residential uses, considering the type of proposed use and its location.

(b) Personal Improvement Services. All personal improvement services that require a Pennsylvania state-issued license, must have licensed personnel on the premises during any hours when the use is open to the public.

(c) Personal Credit Establishments. Personal credit establishments are subject to the following supplemental use regulations.

[1] Required Separation

- [i] It is unlawful to establish a check cashing establishment within 1,000 feet of another check cashing establishment.
- [ii] It is unlawful to establish a pawnbroker within 1,000 feet of another pawnbroker.

- [iii] Required separation distances must be measured in a straight line between the respective floor areas occupied by the check cashing establishment or pawnbroker uses.

- [2] **Licensing and Records.** Pawnbrokers must comply with all record-keeping requirements of the State Pawnbrokers License Act. Records must be available for review by the police department upon request.

660-31.E DAY CARE CENTER, ADULT

- (1) **Use Category Description.** A facility in which adult daily living services are provided for less than 24 hours per day to 4 or more persons 16 years of age or older who require assistance to meet personal needs and perform daily activities.
- (2) **Supplemental Use Regulations.** Adult day care centers are subject to the following supplemental use regulations:
 - (a) The minimum lot area requirement for an adult day care center is 3,000 square feet.
 - (b) In zones requiring special exception approval for adult day care centers, such use must be accessory to a lawful place of worship, hospital, community center, primary or secondary school, or similar principal public or civic use type.
 - (c) The applicant must submit a narrative describing the particulars of the operation including number of staff persons, licensed capacity, and hours of operation; and a site plan showing at least the location and dimensions of the building, drop-off/loading areas, parking, and waste storage areas.
 - (d) The adult day care center must have a valid license issued by the Pennsylvania Department of Aging, as applicable before occupancy.
 - (e) Adult day care centers are not permitted within dwelling units.
 - (f) An adult day care center with more than 12 clients may not be physically attached to or be within any structure containing one or more dwelling units.

660-31.F EATING AND DRINKING PLACES

- (1) **Use Category Description.** Establishments that serve food or beverages for on- or off-premise consumption.
- (2) **Subcategories.**
 - (a) **Bring-Your-Own-Bottle (BYOB) Establishment.** Either of the following:
 - [1] A place of assembly or any other use defined in this article, other than a dwelling unit, including

but not limited to restaurants, taverns, clubs and social buildings, that is not licensed by the Pennsylvania Liquor Control Board, in which no intoxicating beverages are sold, but where patrons are permitted to bring intoxicating beverages upon the premises solely for their own use and consumption; or

- [2] Any premises that:
 - [i] Is open to public gathering on a regular or continuing basis or to which the public is admitted upon payment of an admission fee or charge of any kind;
 - [ii] Is open after midnight;
 - [iii] May or may not serve food and beverages; and
 - [iv] Is not licensed for the sale of alcoholic beverages.
- [3] A facility that is rented for a limited period of time, not to exceed 6 hours in length, nor to exceed one rental in a 24-hour period, nor to occur between the hours of 12:00 midnight and 8:00 a.m., by individuals or an organization for the purpose of a private party in which alcoholic beverages are carried onto the premises is not considered a BYOB establishment.
- (b) **Catering.** Businesses that prepare food for events that occur at a separate location. Catering businesses do not offer individual meals for on-site dining, pick-up, or delivery. Catering and restaurant uses may be combined if both use types are allowed in the subject zone and comply with all applicable use regulations. A commissary located on the premises of a use in the Civic & Institutional Use group, preparing food in bulk for distribution to satellite locations associated with the principal use, is considered accessory to the principal use and not a catering use.
- (c) **Food Truck.** A readily movable vehicle from which food items are sold or served to the general public. Readily movable vehicles include those that are self-propelled or pushed or pulled to a specific location.
- (d) **Restaurant.** An establishment that serves ready-to-eat food and beverages. The restaurant subcategory includes full-service restaurants, take-out restaurants, cafés, cafeterias, ice cream/yogurt shops, donut shops, banquet halls, coffee shops, and similar establishments. A snack bar at a public or community playground, playfield, golf course, park or swimming pool operated solely by the

agency or group operating the recreational facilities, and for the convenience of patrons of the facility, is not deemed to be a restaurant. A restaurant may include the accessory sale and service of alcohol, but establishments that meet the definition of a "Bring-Your-Own-Bottle (BYOB) Establishment" or a "Tavern" must comply with all regulations that apply to BYOB establishments or Taverns, respectively. Drive-through facilities are allowed only as indicated in the building type regulations of [Article 3](#).

(e) Tavern. Uses that cater primarily to adults, 21 years of age and older and that sell and serve of alcoholic beverages by the drink to the general public and where food or packaged alcoholic beverages are served or sold as accessory to the principal use. The tavern subcategory includes bars, taverns, brewpubs, nightclubs, and similar establishments. The tavern subcategory also includes smoking lounges, in which the smoking of tobacco products, electronic cigarettes, or other legal substances is permitted. Examples of smoking lounges include, but are not limited to, cigar lounges, hookah lounges, vape lounges, tobacco clubs, tobacco bars, etc.

(3) Supplemental Use Regulations.

(a) Late-Night Operations.

- [1] Special exception approval is required for all eating and drinking place uses that are proposed to be open to the public during any hours between 2:00 a.m. and 6:00 a.m., provided that this requirement does not apply in MX-D and GX-D zones. Additionally, special exception approval is required for all eating and drinking place uses in MX-N and GX-N zones that are proposed to be open to the public during any hours between 10:00 p.m. and 6:00 a.m.
- [2] In considering the special exception, the zoning hearing board must consider whether the late-night hours are likely to create nuisances and incompatibilities with nearby residential uses, considering the type of proposed use and its location.

[3] Frying of Foods. On-site deep fat frying of foods is prohibited in MX-N and GX-N zones when the subject building is occupied by dwelling units or is attached to a building occupied by dwelling units.

(b) Bring-Your-Own-Bottle (BYOB) Establishments. All bring-your-own-bottle establishments are subject to the following supplemental use regulations:

- [1] Such uses must comply with the regulations in Chapter 159 of the city code.
- [2] It is unlawful to establish a BYOB establishment within 1,000 feet of any:
 - [i] Primary or secondary school;
 - [ii] Residential dwelling unit;
 - [iii] Child care facility;
 - [iv] Place of worship; or
 - [v] MX-N, GX-N, or N zoned lot.

(c) Food Trucks. Food trucks located on private property are subject to the following regulations:

- [1] Food trucks may be a principal use or an accessory use.
- [2] Food trucks may not occupy more than 25% of the site on which they are located.
- [3] Food trucks must be located within a paved, level parking area with minimum dimensions of 35 feet by 15 feet or at least 70 feet by 15 feet if the food truck is more than 27 feet in length.
- [4] Food trucks must be set back:
 - [i] At least 10 feet from street lot lines;
 - [ii] At least 35 feet from side and rear property lines abutting N-zoned lots; and
 - [iii] At least 20 feet from all other lot lines.
- [5] Food trucks may not be parked within 100 feet of the public entrance to a restaurant.
- [6] At least 2 off-street parking spaces must be provided per food truck. Food trucks may not occupy parking spaces that are provided to satisfy the off-street parking requirement of any other use that is operating at the same time as the food truck.
- [7] Food trucks may not sell or serve alcohol.
- [8] Food trucks must provide at least one trash receptacle and one recycling receptacle for use by patrons.
- [9] Food trucks may not obstruct or interfere with the free flow of pedestrian or vehicular traffic.
- [10] Food trucks are subject to the noise regulations of Chapter 400.
- [11] Food trucks are limited to signs posted on the interior or exterior of the food truck.
- [12] Food truck operators must collect and remove all litter and debris generated within at least a 25-foot radius of the food truck.

[13] See also the vendor regulations of Chapter 626.

660-31.G ENTERTAINMENT, SPECTATOR/PARTICIPANT

- (1) **Use Description.** Uses that provide gathering places for participant or spectator recreation, entertainment or other assembly activities that are not more specifically identified under the description of other use categories. Spectator/participant entertainment uses may provide incidental food and beverage service. Typical uses include stadiums, sports arenas, auditoriums, cinemas, theaters, bowling centers, and video arcades.
- (2) **Subcategories.** The spectator/participant entertainment use category includes the following subcategories:
- (a) **Betting Use.** Any place in which lawful gambling activities occur, including, but not limited to, off-track parimutuel betting or any use of electronic gambling devices (not including state lottery sales or lawful small games of chance).
- (b) **Skills Game Establishment.** Any place in which one or more skills game machines are present. Skills game machines are electronic machines that accept cash payment for the chance of a cash reward and that may not otherwise be regulated by the State of Pennsylvania.
- (c) **Indoor, Small.** Spectator/participant entertainment uses, other than gambling or skills game establishments, conducted primarily within completely enclosed buildings with a floor area of 25,000 square feet or less.
- (d) **Indoor, Large.** Spectator/participant entertainment uses, other than gambling or skills game establishments, conducted primarily within completely enclosed buildings with a floor area of more than 25,000 square feet.
- (e) **Outdoor.** Spectator/participant entertainment uses conducted primarily outdoors.

(3) Supplemental Use Regulations

- (a) Special exception approval is required for all spectator/participant entertainment uses that are proposed to be open to the public during any hours between 2:00 a.m. and 6:00 a.m., provided that this requirement does not apply in MX-D and GX-D zones. Additionally, special exception approval is required for all spectator/participant entertainment uses in MX-N and GX-N zones that are proposed to be open to the public during any hours between 10:00 p.m. and 6:00 a.m.

- (b) In considering the special exception, the zoning hearing board must consider whether the late-night hours are likely to create nuisances and incompatibilities with nearby residential uses, considering the type of proposed use and its location.

660-31.H FUNERAL AND MORTUARY SERVICE

- (1) **Use Category Description.** The funeral and mortuary service use category includes establishments that provide services related to the death of a human or domestic, household pet, including funeral homes and mortuaries. Note: Crematoriums are classified in the moderate impact manufacturing use category and may also be approved as accessory uses in cemeteries.

660-31.I LODGING

- (1) **Use Category Description.** Establishments that provide temporary overnight lodging to transient guests, generally for fewer than 30 days at a time. Lodging uses sometimes provide food and beverage service, primarily to registered guests.
- (2) **Subcategories.** Subcategories of the lodging use category include hotels, motels, and the following:
- (a) **Bed and Breakfast Inn.** A detached house in which a full-time resident and owner/operator offers 2 or more guest rooms for overnight lodging and meal service for compensation.
- (3) **Supplemental Use Regulations**
- (a) **Bed and Breakfast Inns.** Bed & breakfast inns are subject to the following supplemental regulations:

- [1] Bed & breakfast inns may contain no more than 10 guest rooms.
- [2] Guest rooms may not be offered for rental for periods of more than 14 consecutive days.
- [3] The owner/operator of the bed & breakfast inn must occupy the subject property as their principal full-time residence.

660-31.J MARINA

- (1) **Use Category Description.** Facilities open to the public that provide moorage, launching, storage, fueling, supplies and services (other than repair) commonly associated with storing, maintaining and operating recreational and commercial watercraft.

660-31.K OFFICE

- (1) **Use Category Description.** The office use category includes workplaces of companies and organizations providing administrative, professional, executive, clerical, financial, management, outpatient medical, and research

and development services. See 660-51 for regulations governing temporary offices.

(2) **Subcategories.** The office use category includes the following subcategories:

- (a) **Administrative, Business or Professional Office.** Workplaces of firms, organizations, or agencies providing professional, executive, management, clerical, administrative, financial, outpatient medical or legal services. Examples of administrative, business, and professional offices include those providing accounting, architecture, outpatient medical, computer software design, engineering, graphic design, interior design, investment, insurance, or legal services, as well as broadcast and recording studios and offices of physicians, dentists, psychiatrists, psychologists, chiropractors, and other members of the medical profession regulated by the State Board of Medicine.
- (b) **Medical Lab or Health-Related Service.** Medical laboratories, dental laboratories, blood or plasma collection centers and similar uses.
- (c) **Financial Service.** Establishments involved in the exchange, lending, borrowing and safe-keeping of money. Examples include banks and credit unions. Automatic teller machines, kiosks and similar facilities that do not have on-site employees are not classified in the financial service subcategory if they meet the criteria for classification as an accessory use. This use subcategory does not include personal credit establishments (see the indoor consumer service use category).
- (d) **Service Office.** Establishments engaged in applied scientific or industrial research and testing services leading to the development of new products and processes as well as offices of contractors and service technicians that typically involve accessory outdoor storage of goods, equipment, or service vehicles.

[1] Service vehicles are limited to box trucks, vans and light-duty trucks. Uses involving accessory storage of larger vehicles are classified in the industrial service use category (see 660-32.E).

[2] Uses that involve the handling of hazardous substances; the mass production, distribution or sale of products; or that produce odors, dust, noise, vibration or other external impacts that are detectable beyond the property lines of the subject property are classified in the manufacturing and industry use group.

(e) **Walk-In Office.** Workplaces primarily providing direct services to patrons or clients, typically not requiring appointments. This subcategory classification includes employment agencies, insurance agencies, real estate agent offices, travel agencies, and utility company offices.

660-31.L RETAIL SALES

- (1) **Use Category Description.** The retail sales use category includes establishments involved in the sale, lease or rental of products or goods to the ultimate consumer, including those that sell or otherwise provide pharmaceuticals, groceries, sundry goods, convenience goods, consumer shopping goods, household goods, plants and flowers, or hardware.
- (2) **Subcategories.** The retail sales use category includes the following subcategories:
 - (a) **Indoor.** Retail sales establishments in which any outdoor sales area does not exceed 5% of the use's total floor area.
 - (b) **Outdoor.** Retail sales establishments in which any outdoor sales area exceeds 5% of the use's total floor area. Typical uses include outdoor plant nurseries, garden centers, farmers markets and flea markets.
- (3) **Supplemental Use Regulations.** Retail sales uses are subject to the following supplemental use regulations:
 - (a) **Hours of Operation.** Special exception approval from the zoning hearing board is required if the use is proposed to be open to the public during any hours between 10:00 p.m. and 6:00 a.m. in any MX-N or GX-N zone or between the hours of 2:00 a.m. and 6 a.m. in any other MX or GX zone or IX, I, or P2 zone. In considering the special exception, the zoning hearing board must consider whether the late-night hours are likely to create nuisances and incompatibilities with nearby residential uses, considering the type of proposed use and its location.
 - (b) **Tobacco Sales.** In the MX-N and GX-N zones, retail uses with greater than 10% total floor area dedicated to the sales of tobacco products may not be located within 1,000 feet of another retail use with greater than 10% total floor area dedicated to the sales of tobacco products, measured in a straight line between property lines.

660-31.M SELF-SERVICE STORAGE

(1) **Use Category Description.** The self-service storage facility use category includes enclosed, climate-controlled establishments providing separate, small-scale, self-service storage area leased or rented to

individuals or small businesses. Such facilities are designed and used to accommodate only interior access to storage lockers or drive-up access only from passenger vehicles and two-axle non-commercial vehicles. Mini-warehouse-style self-service storage facilities with external entrances to storage spaces and self-service storage facilities that include outdoor storage areas require special exception approval.

- (2) **Supplemental Use Regulations.** Self-service storage facilities must be laid out and designed to ensure that garage doors or overhead doors serving individual storage units are not visible from abutting streets.

660-31.N VEHICLE SALES & SERVICE

- (1) **Use Category Description.** The vehicle sales and service use category includes uses that provide for the sale, rental, ordinary maintenance, or limited repair of new or used passenger vehicles.

- (2) **Subcategories.** Vehicle sales and service uses include the following subcategories:

- (a) **Personal Vehicle Repair and Maintenance, Minor.**

Use that conduct ordinary maintenance, cleaning, or repair on automobiles, light-duty trucks, boats, and motorcycles, including the incidental sale, installation, and servicing of related equipment and parts. This classification includes the replacement of small automotive parts and liquids as well as emissions testing, quick-service oil, tune-up, audio installation, and brake and muffler shops in which service is provided in enclosed bays and no vehicles are stored outside of enclosed buildings.

- (b) **Personal Vehicle Repair and Maintenance, Major.**

Vehicle repair and maintenance uses that regularly involve disassembly, removal or replacement of major components such as engines, drive trains, transmissions or axles; automotive body and fender work, vehicle painting or similar operations.

- (c) **Personal Vehicle Sales and Rentals.**

Establishments that provide for the sale or rental of new or used autos, light-duty trucks, vans, trailers, motorcycles, motor homes or recreational vehicles, including recreational watercraft. Typical examples include automobile dealers, auto malls, and car rental agencies that involve outdoor display or storage of vehicles visible from street rights-of-way. Personal vehicle sales and rental establishments that occur in completely enclosed buildings with no outdoor storage or display visible from street rights-of-way are classified in the retail sales use category.

- (d) **Fueling Station.** Establishments engaged in retail sales of vehicle fuels for personal vehicles, other

than fleet fueling facilities and truck stops. Fueling stations may dispense conventional vehicle fuels and/or alternative vehicle fuels. Fleet vehicle fueling facilities and truck stops are classified as outdoor warehousing and distribution uses.

- (3) **Supplemental Use Regulations.** All vehicle sales & service uses are subject to the following supplemental use regulations:

- (a) All fuel tanks must comply with state regulations.
- (b) City-approved curbing must be constructed and maintained in a good and safe condition along all street property lines, except at crossovers.
- (c) The entire area of the site traversed by motor vehicles must be hard-surfaced.
- (d) No building space used for repairs or maintenance may have an opening in roof or walls within 15 feet of any lot line of an N zone.
- (e) No lot occupied by a vehicle repair garage or fueling station may be located within 200 feet of a primary or secondary school, or within 50 feet of any MX-N, GX-N, or N-zoned lot.
- (f) All fueling stations must be so arranged and all fueling equipment must be so placed as to permit all servicing on the premises and outside the public right-of-way. Fueling equipment must be set back at least 12 feet from all lot lines. See also the applicable building type regulations of Article 3, including the fuel pump location regulations, and the pump, canopy, and accessory car wash regulations of 660-41.
- (g) All lots must be kept free of paper and rubbish. No abandoned or junk vehicle may be stored on the premises (note: storage of junk or abandoned vehicles is classified as a high-impact industry under the manufacturing & industry use group).
- (h) All areas used for the storage of vehicles awaiting repair or maintenance must be screened in accordance Article 7.

660-32 Manufacturing & Industry Group

The manufacturing and Industry use group includes establishments involved in manufacturing, processing, fabrication, packaging, or assembly of goods or the servicing of industrial or commercial machinery, equipment, products or by-products. Uses in this group may include offices and ancillary retail sales as accessory uses.

660-32.A ARTISAN MANUFACTURING

- (1) **Use Category Description.** The artisan manufacturing use category includes indoor work spaces used by

660-32 Manufacturing & Industry Group

artists for creation of art or the practice of their artistic endeavors or by craftspeople that produce consumer goods by hand-manufacturing involving the use of only hand tools and small-scale, light mechanical equipment. Artisan manufacturing uses occur in completely enclosed buildings with no outdoor operations, storage or regular commercial truck parking/loading. Typical uses include woodworking; custom furniture shops; reupholstering; cabinet-making; ceramic studios; jewelry manufacturing; confections and custom-made food items; and artwork including painting, printmaking and sculpture.

660-32.B LOW-IMPACT MANUFACTURING

(1) Use Category Description. The low-impact manufacturing use category includes indoor work spaces for uses that do not meet the definition of artisan manufacturing and that do not, as part of their normal operations, generate noticeable off-site impacts in terms of noise, smoke, particulate matter, odors, vibration or heavy truck traffic. Typical examples of low-impact manufacturing uses include: commercial laundries and linen supply services, apparel manufacturing, bakery products manufacturing, bottling plants, ice manufacturing, mattress manufacturing and assembly, microbreweries, micro distilleries, musical instrument and parts manufacturing, newspaper printing and binderies, and uses involved in growing, washing, packaging and storage of fruits, vegetables and other plant products in enclosed buildings.

660-32.C MODERATE-IMPACT MANUFACTURING

(1) Use Category Description. The moderate-impact manufacturing use category includes establishments that manufacture products from extracted or raw materials or recycled or secondary materials or that, as part of their normal operations, generate noticeable off-site impacts in terms of noise, smoke, particulate matter, odors, or vibration. The moderate-impact manufacturing use category includes lumber and wood products manufacturing; crematoriums, metal and metal products manufacturing, including enameling and galvanizing; large breweries (i.e., those with an annual production of more than 15,000 barrels or 465,000 gallons); and large distilleries (i.e., those with an annual production of more than 40,000 proof gallons).

(2) Supplemental Use Regulations.

(a) Crematoriums. Crematoriums are prohibited within 250 feet of any MX-N, GX-N, or N-zoned lot, as measured from lot line to lot line.

660-32.D HIGH-IMPACT INDUSTRY

(1) Use Category Description. The high-impact industry use category includes establishments that use hazardous chemicals or procedures; generate hazardous byproducts or explosive hazards; or otherwise have high potential for adverse land use impacts related to community appearance, public safety, environmental impacts, or nearby residents' quality of life. The high-impact industry use category includes junk and salvage yards; waste-related uses; outdoor tire storage, mining, quarrying, and resource extraction operations; tire retreading or recapping; mulching and wood-splitting; fuel storage yards; and processing, storage, or stockpiling of soil, rock, concrete, brick, block, gravel, sand, and similar raw or recycled material.

(2) Supplemental Use Regulations.

(a) Mining, Quarrying, and Extractive Uses. Mining, quarrying, and similar extractive uses are subject to the following supplemental use regulations:

- [1] No new mining, quarrying, or similar extractive use excavation or mechanical loading or processing of extracted materials may be located within:
 - [i] 75 feet of the right-of-way of a public street;
 - [ii] 200 feet of the boundary of an N zone; or
 - [iii] 50 feet of any other lot line.
- [2] A landscaped area with a minimum width of 25 feet must be provided around the perimeter of the use, except for necessary perpendicular crossings.
- [3] The zoning hearing board is expressly authorized to require berms, landscaping, fencing and additional setbacks as needed to protect the public safety and to avoid conflicts with neighboring uses.
- [4] A copy of mapping and all application materials submitted to the State Department of Environmental Protection must be provided to the zoning officer.

(b) Junk Yards and Salvage Yards. Junk yards, salvage yards, and scrap yards are subject to the following supplemental use regulations:

- [1] All new and expanded uses must be surrounded by a secure security fence or wall with a minimum height of 8 feet. All perimeter security fences and walls must be placed on the inside of any required landscape buffers (see 660-72 and 660-73).

- [2] Outdoor storage and processing of junk or scrap must be set back at least:
 - [i] 100 feet from the lot line of a dwelling or a N zone, and
 - [ii] 50 feet from the right-of-way of a public street or any other lot line.
- [3] Any bulk mechanical crushing of metals must be set back a minimum of 250 feet from any N zone.
- [4] Cleared driveways must be provided around and throughout the junkyard to allow access by emergency vehicles. Off-street parking areas may not obstruct such emergency access.
- [5] Burning or incineration of junk or vehicles is prohibited. All gasoline and oil must be drained from vehicles and be properly disposed of. All batteries must be removed from vehicles and stored on an impervious surface that is drained to collect any acids for proper disposal.
- [6] No junk, salvage, or other material may be stored at a total height of more than 25 feet above the ground.
- [7] See also the outdoor tire storage regulations, below.

(c) Outdoor Tire Storage. Outdoor storage areas for used tires are subject to the following supplemental use regulations:

- [1] Any area used for the bulk overnight outdoor storage or processing of used tires must be set back at least 50 feet from any lot line and be separated by at least 50 feet from any other area containing 100 or more used tires. Required setback and separation areas may not contain combustible material.
- [2] Any area used for the outdoor storage of 200 or more used tires must comply with the supplemental use regulations for junk and salvage yards.
- [3] No outdoor used tire storage area may contain more than 500 used tires.
- [4] Outdoor used tire storage areas may not exceed 25 feet in height.

(d) Waste-Related Use. Lands and facilities used for waste disposal, processing, incineration, or transfer operations are subject to the following supplemental use regulations:

- [1] All solid waste processing and storage areas must be set back at least 150 feet from: public

street rights-of-way, exterior lot lines, and perennial rivers or streams.

- [2] All solid waste processing and storage areas must be set back at least 300 feet from any lot occupied by a dwelling unit.
- [3] Open outdoor burning is prohibited.
- [4] All solid waste processing, storage, loading and unloading must occur within an enclosed building or enclosed containers. All processes must occur on an impervious surface that prevents polluted runoff from flowing from the site or into the groundwater.
- [5] The use must be surrounded by secure fencing and gates.
- [6] A minimum lot area of 8 acres is required.
- [7] The use must be operated in a manner that prevents the attraction, harborage or breeding of insects, rodents or other vectors.
- [8] An attendant must be on duty during all hours of loading and unloading.
- [9] Radioactive, chemotherapeutic, toxic or infectious materials are prohibited.

660-32.E INDUSTRIAL SERVICE

- (1) Use Category Description.** The industrial service use category includes businesses engaged in the repair or servicing of industrial or commercial machinery, equipment, products or by-products. Typical uses include welding shops; machine shops; heavy truck servicing and repair; towing and vehicle storage yards; bus and taxi storage yards, and fleet fueling facilities.
- (2) Supplemental Use Regulations.** Tractor-trailer combinations, buses, and similar large/heavy vehicles associated with an industrial service use may not be parked within 20 feet of an N zone.

660-32.F RECYCLING USE

- (1) Use Category Description.** Uses that collect, store or process recyclable material for the purpose of marketing or reusing the material in the manufacturing of new, reused or reconstituted products.
- (2) Subcategories.** The recycling use category includes the following subcategories:
 - (a) Recyclable Material Collection.** An establishment that (1) accepts consumer recyclable commodities directly from the consuming party; (2) is staffed by personnel on site during hours of operation; and (3) stores materials temporarily before transferring them to recyclable material processing facilities.

- (b) **Recyclable Material Processing.** Establishments that receive and process recyclable commodities for subsequent use in the secondary market.

660-32.G WAREHOUSING & DISTRIBUTION

- (1) **Use Category Description.** The warehousing and distribution use category includes uses that sell, lease, provide, or distribute goods in large quantities, principally to other commercial, manufacturing, or industrial businesses. Examples include warehouses, food depositories, package delivery services, and household and commercial moving companies. Warehousing and distribution uses may include wholesale sales showrooms. This category does not include uses more specifically identified in the self-service storage use category.
- (2) **Subcategories.** The warehousing and distribution use category includes the following subcategories:
 - (a) **Indoor.** Warehousing and distribution uses conducted primarily within completely enclosed buildings.
 - (b) **Outdoor.** Warehousing and distribution uses with a substantial portion of their stock in-trade displayed or stored outdoors. This use subcategory expressly includes truck terminals (i.e., parking and storage of trucks), truck stops, and warehousing and distribution uses with more than 3 loading bays or docks, and uses engaged in the dispatching and long-term or short-term storage of trucks, buses and similar vehicles.
- (3) **Supplemental Use Regulations**
 - (a) Warehouse and distribution uses with more than 50,000 square feet of indoor gross floor area require a minimum lot area of 5 acres in the IG zone and 8 acres in the IM zone.
 - (b) Tractor-trailer combinations, buses, and similar large/heavy vehicles associated with warehousing & distribution use may not be parked within 20 feet of an N zone. Refrigerated trailers may not be parked within 100 feet of MX-N-, GX-N-, or N-zoned lots.
 - (c) Outdoor warehousing and distribution uses must comply with all applicable regulations related to truck idling, and signs must be posted to warn violators of penalties for violations.
 - (d) Warehousing and distribution uses are subject to the noise regulations of Chapter 400.

660-33 Civic & Institutional Group

The civic and institutional use group includes public, quasi-public, and institutional uses that provide services that benefit the public at-large.

660-33.A CEMETERY

- (1) **Use Category Description.** Lands and facilities for the interment of humans or domestic household pets, including columbariums and mausoleums. Cemeteries may include crematoriums as an accessory use.
- (2) **Supplemental Use Regulation.** Any crematorium must be setback at least 250 feet from any MX-N, GX-N, or N-zoned lot.

660-33.B COLLEGE OR UNIVERSITY

- (1) **Use Category Description.** Institutions of higher learning that offer courses of general or specialized study and are authorized to grant academic degrees. The college use category includes classrooms and instructional spaces, as well as on-campus residence halls, fraternity and sorority houses, administrative buildings, auditoriums and other on-campus uses and facilities that provide customary accessory and support functions for college or university uses.
- (2) **Supplemental Use Regulations.** Colleges and universities are subject to the following supplemental use regulations:
 - (a) The minimum total lot area required for such use is 20,000 square feet.
 - (b) In any zones in which special exception approval is required, any generally applicable off-street parking requirements may be increased if, in the judgment of the zoning hearing board, such consideration as the unavailability of public transportation, the distance from centers of population, or a relatively high percentage of students driving cars make such increased requirements necessary.
 - (c) Illumination for night athletic activities must be properly directed and shielded from view from adjoining rights-of-way and residential areas.

660-33.C COMMUNITY ASSEMBLY

- (1) **Use Category Description.** Facilities for hosting public or private meetings including senior centers, community centers, fraternal organizations, membership clubs, and places of worship. This category includes functionally related facilities for the use of members and attendees such as kitchens, multi-purpose rooms, and storage. It does not include auditoriums, stadiums, convention centers, arenas, schools, or sports facilities that are separately classified and regulated.

(2) Supplemental Use Regulations.

(a) Membership Clubs. Membership clubs are subject to the following supplemental use regulations:

- [1] A membership club must be a nonprofit organization operated primarily for the recreation and enjoyment of the members of such organization and their occasional guests.
- [2] If special exception approval is required, a statement setting forth full particulars on the operation of the use and a copy of the bylaws or articles of incorporation (if incorporated) must be filed with the zoning officer.
- [3] The proposed use shall not adversely affect the safe and comfortable enjoyment of properties in the neighborhood and the design of any structures erected in connection with such use must be in keeping with the general physical character of the area.

(b) Places of Worship. Places of worship are subject to the following supplemental use regulations:

- [1] Places of worship may include a maximum of one dwelling unit, provided such dwelling unit is limited to occupancy by full-time paid religious leader and members of the leader's household.
- [2] Except for the one dwelling permitted by subsection (1) above, any other residential, social service, accessory or related uses must comply with all requirements applicable to such use and be separately approved.
- [3] In GX-N zones, places of worship may not be located in structures that are physically attached to any structure that is used exclusively for residential purposes.

660-33.D DETENTION OR CORRECTIONAL FACILITY

(1) Use Category Description. An institution operated by the city, the state, the federal government or a private party under contract with the city, the state or federal government for the confinement and punishment and treatment or rehabilitation of offenders under the jurisdiction of a court.

660-33.E GOVERNMENTAL USE

(1) Use Category Description. Uses operated by any department, independent agency or instrumentality of the United States, State of Pennsylvania, County of Lehigh, or City of Allentown.

660-33.F HOSPITAL

(1) Use Category Description. The hospital use category includes veteran treatment centers, as well as facilities

providing inpatient medical, surgical, mental health, emergency medical services. Hospitals may also provide outpatient treatment.

(2) Supplemental Use Regulations. Hospitals are subject to the following supplemental use regulations:

- (a)** Buildings must be set back at least 30 feet from any MX-N, GX-N, or N-zoned lot.
- (b)** The facility must obtain all required licenses or permits from applicable state, county or city agencies before the commencement of operations.

660-33.G LIBRARY OR CULTURAL EXHIBIT

(1) Use Category Description. Museum-like preservation and exhibition of objects in one or more of the arts and sciences, gallery exhibition of works of art or library collections of books, manuscripts and similar materials operated by a public or quasi-public agency.

660-33.H PARKS AND OPEN SPACE

(1) Use Category Description. Recreational, social or multi-purpose uses associated with public parks and open spaces, including playgrounds, playfields, play courts, community centers and other facilities typically associated with public parks and open space areas. Also includes public and private golf courses, tennis clubs, "protected" or undevelopable lands, and undeveloped land left in a natural state for specific use as visual open space or natural resource preservation purposes.

660-33.I SCHOOL

(1) Use Category Description. Public and private schools at the primary, elementary, middle school or high school level that provide basic, compulsory, state-mandated education.

(2) Supplemental Use Regulations. Schools are subject to the following supplemental use regulations:

- (a)** The minimum total lot area required for a school use is 20,000 square feet.
- (b)** In any zones in which special exception approval is required, any generally applicable off-street parking requirements may be increased if, in the judgment of the zoning hearing board, such consideration as the unavailability of public transportation, the distance from centers of population, or a relatively high percentage of students driving cars make such increased requirements necessary.
- (c)** Illumination for night athletic activities must be properly directed and shielded from view from adjoining rights-of-way and residential areas.

660-33.J TRANSPORTATION FACILITIES

- (1) Use Category Description.** Stations, passenger docks, off-street passenger waiting areas, and loading/unloading areas for local and regional transit and transportation services. Typical uses include airports, rail and bus stations, helicopter landing facilities (heliports and helistops), passenger transfer facilities, ticket purchasing and waiting areas out of the public right-of-way, restrooms, and accessory uses such as cafés. Street-side boarding locations, such as bus stops, are not classified or regulated as transportation facilities.
- (2) Supplemental Use Regulations.** Helicopter landing facilities are subject to the following supplemental use regulations:
 - (a)** Landing pads must be set back at least 100 feet from any sidewalk, street or other public area and may not be located within 600 feet of any N zone.
 - (b)** Landing pads must be clearly marked and signed around the perimeter. The landing pad must include a circle with a diameter at least 1.5 times the length of the longest helicopter using the facility.
 - (c)** Landing pads located within 1,500 feet of an N zone may not routinely be used for landings or take-offs between 11:00 p.m. and 7:00 a.m., except for emergency medical purposes.
 - (d)** A paved surface must be provided to prevent the blowing of dust, dirt or other objectionable matter.
 - (e)** The facility must be provided with such fire protection devices and equipment as may be deemed necessary by the fire department.
 - (f)** The applicant must submit plans to the zoning office that will direct pilots to utilize approach and departure routes that will minimize conflicts with residential neighborhoods. This provision does not apply to emergency medical helistops.

660-33.K INFRASTRUCTURE AND UTILITIES, MINOR

- (1) Use Category Description.** Public utilities and Infrastructure services that typically have very limited adverse visual or operational impacts and that require location in or very near the area where the service is provided. Minor utilities and public service facilities do not regularly have employees at the site and typically have few if any impacts on surrounding areas. Typical uses include: underground electric distribution substations; electric transformers; water conveyance systems; stormwater facilities and conveyance systems; telephone switching equipment and emergency communication warning/broadcast facilities.

660-33.L INFRASTRUCTURE AND UTILITIES, MAJOR

- (1) Use Category Description.** Public utilities and Infrastructure services that typically have substantial visual or operational impacts on nearby areas. Typical uses include high-voltage electric substations, utility-scale power generation facilities, including principal use solar energy systems, and principal use wind energy conversion systems and utility-scale water storage facilities, such as water towers and reservoirs. See also Section 619 of the Pennsylvania *Municipalities Planning Code*, which provides a process for limited exemptions.
- (2) Supplemental Use Regulations**
 - (a) General.** All major infrastructure and utility uses that require special exception approval are subject to the following supplemental use regulations:
 - [1] The applicant must provide evidence to the zoning hearing board that the proposed use in the location specified is necessary for the convenient and efficient operation of the public infrastructure or utility system.
 - [2] The design of any structure or use in connection with such use must conform to the general character of the neighborhood in which it is proposed to be located and will not adversely affect the safe and comfortable enjoyment of properties in the neighborhoods in which it is located.
 - (b) Wind Energy Conversion Systems (Principal Use).** Wind energy conversion systems that constitute the principal use of property are subject to the following supplemental use regulations:
 - [1] All wind turbines must be setback from a lot line a minimum distance not less than 2 times the maximum height to the top of the extended blade. Wind turbine setbacks are measured from the center of the base of the turbine.
 - [2] The audible sound from the wind turbine(s) may not exceed 45 A-weighted decibels, as measured at the property line.
 - [3] The owner of the system must completely remove all aboveground structures within 12 months after the system is no longer used to generate electricity.
 - [4] Wind turbines shall not be climbable for at least the first 12 feet above the ground level.
 - [5] Lattice-type towers and towers using guy wires are prohibited.

660-33 Other Principal Uses**DRAFT**

- [6] The system must include automatic devices to address high-speed winds, such as mechanical brakes and over-speed controls.
- [7] Plans for minimizing bird and bat collisions with wind turbines through careful siting, blade design/color, and operational procedures (e.g., curtailment) must be submitted with the special exception application, or if special exception approval is not required, with the zoning permit application.
- [8] Accessory electrical facilities are allowed, such as a transformer, provided that any building must comply with setback requirements for a principal building.
- [9] A site plan must be submitted.
- [10] Temporary towers designed to test possible locations for a wind energy conversion are permitted by right in IG and IM zones, provided they are removed within one year and comply with the setback requirements of this section.

(c) Solar Energy Systems (Principal Use). Solar energy conversion systems that constitute the principal use of property are subject to the following supplemental use regulations:

- [1] If the system is not attached to a building roof and covers a total of more than 3,000 square feet of lot area, the devices must be separated from abutting N zones by a buffer in accordance with 660-73.
- [2] Systems must be constructed and installed so as not to emit glare onto adjoining properties.
- [3] Solar energy systems must be completely removed from the property within 6 months after they are no longer used for energy production.

660-34 Other Principal Uses**660-34.A AGRICULTURE**

- (1) Use Category Description.** Outdoor areas managed and maintained by an individual, group or business entity to grow and harvest food crops or non-food crops (e.g., flowers) for sale or distribution.
- (2) Subcategories.** The agriculture use category includes the following use subcategories:
 - (a) Community Garden.** Outdoor areas that are managed and maintained by a group of individuals to grow and harvest food crops or non-food crops (e.g., flowers). A community garden area may be divided into separate garden plots for cultivation

by one or more individuals or may be farmed collectively by members of the group. Community gardens may be principal or accessory uses.

- (b) Urban Farm, Outdoor.** Outdoor areas used for growing and harvesting food crops or non-food crops.
- (c) Urban Farm, Indoor.** Indoor areas used for growing food crops or non-food crops. Typical uses include greenhouses, vertical farming, hydroponic systems and aquaponic systems.

660-34.B COMMUNICATION, COMMERCIAL

- (1) Use Category Description.** Facilities used for the transmission or reception of radio, television, wireless telephone, pager, commercial mobile radio service or any other wireless communications signals.
- (2) Subcategories.** Commercial communication facilities include the following subcategories:
 - (a) Antennas.** Omnidirectional antennas, whip antennas, and directional or panel antennas owned or operated by any person or entity licensed by the Federal Communications Commission (FCC) to operate such device. Satellite dish antennas, television antennas for household use and amateur radio equipment (including ham or citizen band radio antennas) are considered accessory structures and are not regulated as commercial communication antennas.
 - (b) Tower.** A structure other than a building, such as a monopole, self-supporting or guyed tower, designed and used to support commercial communications antennas.
- (3) Supplemental Use Regulations.** Commercial communication antennas and towers are subject to the following supplemental use regulations, provided that these regulations must be applied within the constraints of the Telecommunications Act of 1996 and Section 6409 of the *Middle Class Tax Relief and Job Creation Act of 2012* (Spectrum Act):
 - (a)** Commercial communications towers are not permitted within 300 feet of any N zone.
 - (b)** Commercial communications towers are subject to the following:
 - [1] A site plan must be submitted to the zoning office.
 - [2] Towers must be set back from all property lines a minimum distance equal to one-half its height or a distance equal to the commercial communication tower fall zone, whichever results in the greater setback.

- [3] The base of a tower must be surrounded by a secure fence at least 8 feet in height.
- [4] Evergreen plantings must be provided to screen the fence surrounding the tower and any other ground level features such as buildings. The screen may be either a hedge (planted no more than 3 feet on center) or a row of evergreen trees (planted no more than 10 feet on center). The evergreen screen must be at least 6 feet in height at time of planting with an expectation to grow to at least 15 feet in height at maturity.
- [5] Towers may not exceed 150 feet in height except in I zones. Towers in I zones may not exceed 180 feet in height.

- (c) Towers and antennas must comply with wind resistance requirements of the prevailing construction code.
- (d) Documentation of FAA approval for towers or antennas exceeding 200 feet in height must be provided. Towers or antennas less than 200 feet in height must comply with the requirements of 14 Code of Federal Regulations Part 77.13 (a), as amended.
- (e) Towers and antennas may not be artificially illuminated except when required and approved by the FAA and the PennDOT Bureau of Aviation.
- (f) Applicants for proposed towers or antennas located within a 5-mile radius of an existing airport, must notify the airport manager in writing of its intent to place such structure(s). Any comments received from the airport must be considered in the processing of the application for the proposed commercial communications tower or antenna.
- (g) The applicant must provide documentation of PennDOT Bureau of Aviation approval for towers or antennas in accordance with P.L. 837, No. 164 and Title 67 PA Code Chapter 479, Section 479.4.
- (h) The applicant must demonstrate, using technological evidence, that in order to satisfy its functional requirements, the tower and/or antenna could not utilize an existing structure. Also, if a tower is proposed, that there are no existing structures within 1/4 mile of the site on which to place the antenna.
- (i) If a tower and/or antenna remains unused for a period of 12 consecutive months, the owner or operator must so notify the zoning office within 30 days of the conclusion of this 12-month period and must dismantle and remove the tower and/or

antenna within 6 months of receiving notice to do so by the city. In addition, all portions of the base that are at or above the existing grade must be demolished and removed from the site.

- (j) A tower or antenna necessary for and clearly primarily used for emergency communications by a police department, fire company, emergency medical service, and other similar public safety organizations is exempt from the supplemental use regulations of this section.

660-34.C LIVE/WORK UNIT

(1) Use Category Description. A dwelling unit or other space within a building that is used jointly for residential and nonresidential purposes that typically exceed the impacts of a home occupation use.

(2) Supplemental Use Regulations. Live/work units are subject to the following supplemental use regulations:

- (a) Nonresidential uses are limited to:
 - [1] Retail sales; restaurants; personal services; and business or professional offices; provided that such nonresidential use is permitted within the zone in which the live/work unit is located or, in the case of an adaptive reuse project, such uses approved as part of the special exception application.
 - [2] Uses involving the creation of art including paintings, drawings, sculptures, ceramics, music, custom crafts and literature; music and dance instruction; or dramatic art.
- (b) No more than 6 persons may be present at the same time for instruction.
- (c) No more than 2 employees may be present at any one time in addition to the residents of the residential space.
- (d) No more than 75% of the habitable floor area of the live/work unit may be used for nonresidential purposes. However, the portion of the nonresidential use that attracts customers such as retail and/or gallery space is limited to 50% of the habitable floor area.
- (e) The following regulations apply to live/work units located in N zones:
 - [1] A live/work unit may display one non-illuminated wall sign with a maximum area of 2 square feet.
 - [2] A live/work unit may include gallery space and involve occasional on-site retail sales of art that was primarily produced on the premises.

660-33 Other Principal Uses

- (f) A live/work unit in a non-N zone may include exhibitions of art subject to meeting all applicable city codes.
- (g) Any kilns must be electrically powered, as opposed to directly burning their own supply of fuel.

660-34.D OFF-STREET PARKING

- (1) **Use Category Description.** Surface parking lots or parking garages located on a lot that is not occupied by another principal use. Includes parking areas that are available for use by the general public as well as off-site parking areas that serve principal uses on other lots (see also the off-site parking regulations of 660-85.B).
- (2) **Supplemental Use Regulations.** Off-street parking uses are subject to the following supplemental use regulations:
 - (a) Off-street parking facilities may not be used for sales, long-term storage, repair work or servicing of any kind.
 - (b) Off-street parking facilities are subject to all applicable landscape and site design regulations of Article 7 and parking area layout and design regulations of 660-86.
 - (c) Off-street parking facilities are exempt from building coverage limitations that may apply within the subject zone.
 - (d) Off-street parking facilities located in an Industrial zone that abuts or is across the street from an N zone may not be used for the parking of tractors, tractor trailers, buses, or commercial vehicles equal to or greater than a Class 5 unless such parking or vehicle storage is expressly approved as part of special exception.
 - (e) Within an N zone, off-street parking areas are limited exclusively to the parking of passenger automobiles.

ARTICLE 5. ACCESSORY STRUCTURES & USES

660-35 General 5-2
660-36 Accessory Dwelling Units 5-2
660-37 Drive-Through Facility 5-3
660-38 Electric Vehicle Charging 5-4
660-39 Fences and Walls 5-4
660-40 Food Trucks 5-5
660-41 Fuel Pumps, Canopies, and Accessory Car Wash Facilities 5-5
660-42 Home Occupations 5-6
660-43 Outbuildings 5-8
660-44 Outdoor Display 5-8
660-45 Outdoor Storage 5-9
660-46 Parking Structures 5-9
660-47 Pigeon Keeping 5-9
660-48 Rooming and Boarding 5-9
660-49 Small Wind Energy Conversion Systems 5-9
660-50 Solar Energy Systems 5-10
660-51 Temporary Uses and Structures 5-10

660-35 General

660-35.A USES AND STRUCTURES AUTHORIZED

Accessory uses and structures are allowed only in connection with lawfully established principal uses and principal structures. Allowed accessory uses and structures are limited to those expressly identified in this zoning ordinance as well as those that, in the determination of the zoning officer, satisfy all of the following criteria:

- (1) They are customarily found in conjunction with the subject principal use and structure;
- (2) They are subordinate and clearly incidental to the principal use of the property;
- (3) They are operated and maintained by the owners or lessees of the principal use; and
- (4) They serve a necessary function for or contribute to the comfort, safety or convenience of the owners or lessees of the principal use.

660-35.B GENERALLY APPLICABLE REGULATIONS

The regulations of this section apply to all accessory uses and structures unless express provisions of this zoning ordinance establish more specific regulations for a particular type of accessory use or accessory structure.

- (1) **Location.** Accessory uses and structures must be located on the same lot as the principal use and principal structure to which they are accessory, except that an above-ground swimming pool or storage shed of 150 square feet or less may be located on a lot abutting a lot occupied by the principal use or structure to which the pool or shed is accessory if the abutting lots are under common ownership.
- (2) **Time of Establishment.** No accessory building or structure other than a fence or temporary construction office may be placed on a lot before construction of the principal building.
- (3) **Attached Accessory Structures.** Accessory structures attached to a principal structure are regulated as principal structures.
- (4) **Height.** Accessory structures may not exceed 15 feet in height, unless otherwise specified in this ordinance.
- (5) **Setbacks.** The parking and accessory structure tables for each building type in Article 3 establish siting and setback regulations for key accessory structures. All other accessory structures must be set back from any side or rear lot line a minimum of 3 feet and from any street lot line a minimum of 10 feet.
- (6) **Yard.** An accessory structure is not allowed in any front yard, except as otherwise expressly stated in this ordinance.

- (7) **Design.** Accessory buildings with a building footprint of 250 square feet or more that are visible from A or B streets must comply with roof type and building material regulations that apply to principal building on the lot.

660-36 Accessory Dwelling Units

660-36.A APPLICABILITY

The regulations of this section govern accessory dwelling units (ADUs), that occupy a permitted principal or accessory outbuilding on the subject property.

660-36.B PURPOSE

The ADU regulations of this section are intended to help advance the city's housing and planning policies by:

- (1) Accommodating additional housing units while at the same time preserving the physical form of existing neighborhoods;
- (2) Allowing efficient use of the city's existing housing stock and infrastructure;
- (3) Providing housing options and choices that respond to varying income levels, ages, household sizes, and lifestyle choices;
- (4) Providing a means for aging residents to remain in their homes and neighborhoods, and obtain extra income, security, companionship and assistance; and
- (5) Promoting a broader range of accessible and more affordable housing.

660-36.C REGULATIONS

All accessory dwelling units are subject to the general regulations of this subsection.

- (1) **Where Allowed.** The number and location of dwelling units tables for each building type in Article 3 identify the zones in which accessory dwelling units are allowed, provided further that:
 - (a) ADUs are allowed only on lots occupied by a single (one) dwelling unit;
 - (b) The total floor area of the principal dwelling unit and accessory dwelling unit, combined, must be at least 1,750 square feet; and
 - (c) Any lot to be occupied by a detached ADU (i.e., ADU within an outbuilding) must have access to an alley or street that abuts the subject lot's rear or street side lot line.
- (2) **Sewer Connection.** All accessory dwelling units must be evaluated by the Pennsylvania Department of Environmental Protection to determine the adequacy of proposed sewer connections.

- (3) Number.** No more than one accessory dwelling unit is allowed per lot.
- (4) Methods of Creation.** An accessory dwelling unit may be created through any of the following methods:
 - (a)** Converting existing floor area within the interior of a principal dwelling unit;
 - (b)** Adding floor area to an existing principal dwelling unit to accommodate an accessory dwelling unit;
 - (c)** Constructing an outbuilding (see 660-43) on a lot occupied by single principal dwelling unit;
 - (d)** Converting space within an existing outbuilding on a lot occupied by single principal dwelling unit to accommodate an accessory dwelling unit; or
 - (e)** Constructing a new principal dwelling unit that includes an internal accessory dwelling unit or that includes an accessory outbuilding occupied by an accessory dwelling unit.
- (5) ADU Floor Area.** The floor area of an accessory dwelling unit may not exceed 800 square feet or 40% of the floor area of the principal dwelling unit, whichever is less. ADUs are exempt from the general minimum dwelling unit floor area requirements of Table 660-3, but they must comply with the alternative minimum floor area requirements of Table 660-4. Refer to the Property Rehabilitation and Maintenance Code (Chapter 455) for additional requirements.
- (6) Household Size.** The total number of residents that reside in the accessory dwelling unit and the principal dwelling unit, combined, may not exceed the number permitted for a single household, plus 2 additional adults. Within the Student Residence Overlay (SRO), the total number of students residing in the accessory dwelling unit and the principal dwelling unit, combined, may not exceed 2.
- (7) Parking.** At least one off-street parking space is required for an accessory dwelling unit, in addition to required off-street parking for the principal dwelling unit on the lot.
- (8) Building Regulations**
 - (a)** Outbuildings occupied by an accessory dwelling unit must be on a permanent foundation.
 - (b)** Only one entrance to a principal dwelling unit containing an accessory dwelling unit may be located on a façade that faces a street, unless the principal dwelling unit contained an additional street-facing entrance before the accessory dwelling unit was created.
 - (c)** New detached accessory dwelling units and building additions to accommodate accessory

dwelling units are subject to compliance with all applicable accessory structure regulations.

- (9) Building Permit Approval.** Before the issuance of a building permit for the construction of any new accessory dwelling unit, plans must be reviewed and approved by the building official to determine compliance with all applicable building and life safety codes.
- (10) Owner Occupancy and Rental.** At least one of the dwelling units on a lot occupied by an accessory dwelling unit must be occupied by a record owner of the subject property. The owner must occupy either the principal dwelling unit or the accessory dwelling unit as their permanent residence for a majority of the days each calendar year.
- (11) Short-Term Rental.** On lots with an accessory dwelling unit, neither the principal unit or the accessory unit may be used as a short-term rental.
- (12) Deed Restriction.** Before the issuance of a permit to establish an accessory dwelling unit, the owner of the subject property must file an affidavit with the zoning officer and record a deed restriction stating that the owners of the subject property agree (1) to comply with the owner occupancy, rental and other applicable restrictions of this zoning ordinance; and (2) to notify all prospective purchasers of such requirements. The deed restriction runs with the land is binding upon the property owner, their heirs and assigns, and upon any parties subsequently acquiring any right, title, or interest in the property. The affidavit and deed restriction must be in a form prescribed by the zoning officer.

660-37 Drive-Through Facility

660-37.A APPLICABILITY

The regulations of this section govern accessory drive-through facilities, which are structures or portions of a building that permit customers to purchase goods or receive services while remaining in their motor vehicle.

660-37.B WHERE ALLOWED

The accessory structure tables for each building type in Article 3 identify the zones in which drive-through facilities are allowed and the siting requirements for such facilities.

660-37.C ADDITIONAL REGULATIONS

- (1) Vehicle Stacking.** Vehicle stacking lanes must be located in the rear yard or the interior side yard.
- (2) Accessory Structures/Signs.** The menu board and speaker must be located in the rear yard or the interior side yard.

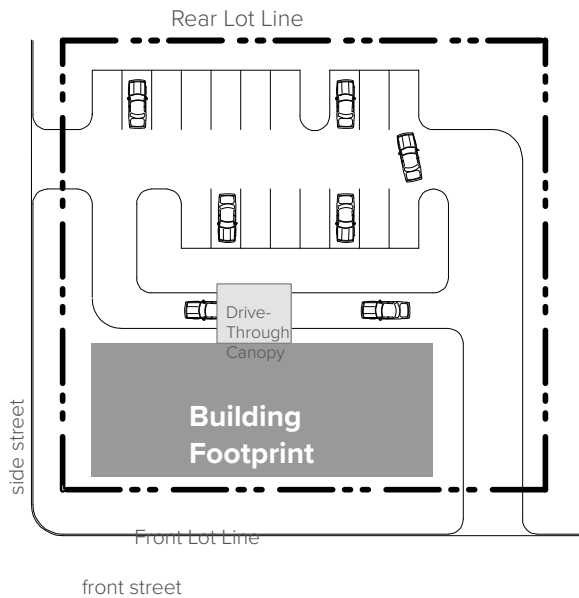

Figure 660(6) Drive-Through Facility

- (3) **Setbacks from N-zoned Lots.** When a drive-through facility is located on a lot that abuts an N zone, the drive-through facility, including the window, menu board, any canopy, and any stacking area for vehicles, must be set back at least 25 feet from the N-zoned lot.
- (4) **Structure.** Drive-through canopies and roofs must match the roof of the principal building. Materials used for the drive-through supports or other features must be repeated from the principal building design.
- (5) **Food Truck Drive-Through Prohibited.** Drive-through facilities and services are not permitted for food trucks.

660-38 Electric Vehicle Charging

660-38.A GENERAL

- (1) The regulations of this section apply to off-street (on-site electric vehicle charging equipment).
- (2) Private (restricted-access) electric-vehicle (EV) charging stations are permitted as accessory uses in all zones.
- (3) Public EV charging stations are permitted as accessory uses to allowed nonresidential uses in all zones.

660-38.B PARKING

- (1) Electric vehicle charging stations may be counted toward satisfying minimum off-street parking requirements.
- (2) Public electric vehicle charging stations must be reserved for parking and charging electric vehicles. Electric vehicles may be parked in any space

designated for public parking, subject to the restrictions that apply to any other motor vehicles.

660-38.C EQUIPMENT

Vehicle charging equipment must be designed and located so as to not impede pedestrian, bicycle or wheelchair movement, or create safety hazards on sidewalks.

660-38.D POSTED INFORMATION

- (1) Information must be posted identifying voltage and amperage levels and any type of use, fees, or safety information related to the electric vehicle charging station.
- (2) Public electric vehicle charging stations must be posted with signs indicating that the space is reserved for electric vehicle charging purposes only. For purposes of this provision, “charging” means that an electric vehicle is parked at an electric vehicle charging station and is connected to the battery charging station equipment.

660-38.E MAINTENANCE

Electric vehicle charging stations must be maintained in all respects, including the functioning of the equipment. A phone number or other contact information must be provided on the equipment for reporting when it is not functioning or other problems are encountered.

660-39 Fences and Walls

660-39.A GENERAL

The general regulations of this subsection apply to all fences and walls unless otherwise expressly stated in this zoning ordinance.

- (1) **Exemptions.** The fence and wall regulations of this section do not apply to:
 - (a) Retaining walls up to 8 feet in height that are necessary to hold back slopes or the wall of a building in a location permitted by this zoning ordinance; or
 - (b) Temporary fences around active construction sites, provided such fencing is removed within 30 days after completion of the construction or expiration of the permit, whichever occurs first.
- (2) **Construction.** Fences and walls must be durably constructed and comply with applicable provisions of the building code.
- (3) **Materials.** No fence or wall may be constructed from scrap sheet metal or similar “junk.” No fence in a neighborhood zone may be constructed out of barbed wire or be electrically charged, unless the applicant proves to the satisfaction of the zoning officer that

barbed wire is necessary to protect persons from an unusual hazard, such as electric transformers.

- (4) **Measurement of Height.** Fence and wall heights are measured from grade level to the top of the main segment of the fence on the exterior side of the fence or wall that faces a street, alley or other property. When a fence and wall are combined (e.g., fence mounted directly atop a wall), the wall is subject to applicable wall regulations, and the overall structure is subject to maximum fence/wall height limits.

660-39.B NEIGHBORHOOD ZONES

The regulations of this subsection apply in neighborhood (N) zones.

- (1) **Fences and Walls in Front Setbacks.** Fences and walls located in required front setbacks may not exceed 4 feet in height, except that fences and walls with a solid to open area ratio of 1:1 or less (such as a picket, split rail or wrought iron fence) may be up to 6 feet in height (maximum).
- (2) **Fences and Walls Outside of Front Setbacks.** Fences and walls located outside front setbacks may not exceed 6 feet in height.
- (3) **Wall Materials.** Walls must be constructed of brick or other masonry with a finished appearance.

660-39.C OTHER ZONES

The regulations of this subsection apply in all zones except neighborhood (N) zones. They do not apply to jails, prisons, electrical substations and similar utility installations.

- (1) **Fences and Walls in Front Setbacks**
 - (a) Fences located in required front setbacks may not exceed 10 feet in height.
 - (b) Walls located in required front setbacks may not exceed 6 feet in height.
- (2) **Fences and Walls Outside of Front Setbacks**
 - (a) Fences located outside front setbacks may not exceed 10 feet in height.
 - (b) Walls located outside front setbacks may not exceed 8 feet in height.

660-40 Food Trucks

660-40.A APPLICABILITY

The regulations of this section apply to food trucks as accessory uses to allowed principal uses. Accessory use food trucks are expressly prohibited in MX-N, GX-N, and N zones.

660-40.B REGULATIONS

Food trucks located on private property are subject to the following regulations:

- (1) Food trucks may not occupy more than 25% of the site on which they are located.
- (2) Food trucks must be located within a paved, level parking area with minimum dimensions of 35 feet by 15 feet or at least 70 feet by 15 feet if the food truck is more than 27 feet in length.
- (3) Food trucks must be set back:
 - (a) At least 10 feet from street lot lines;
 - (b) At least 35 feet from side and rear property lines abutting N-zoned lots; and
 - (c) At least 20 feet from all other lot lines.
- (4) Food trucks may not be parked within 100 feet of the public entrance to a restaurant.
- (5) At least 2 off-street parking spaces must be provided per food truck. Food trucks may not occupy parking spaces that are provided to satisfy the off-street parking requirement of any other use that is operating at the same time as the food truck.
- (6) Food trucks may not sell or serve alcohol.
- (7) Food trucks must provide at least one trash receptacle and one recycling receptacle for use by patrons.
- (8) Food trucks may not obstruct or interfere with the free flow of pedestrian or vehicular traffic.
- (9) Food trucks are subject to the noise regulations of Chapter 400.
- (10) Food trucks are limited to signs posted on the interior or exterior of the food truck.
- (11) Food truck operators must collect and remove all litter and debris generated within at least a 25-foot radius of the food truck.
- (12) See also the vendor regulations of Chapter 626.

660-41 Fuel Pumps, Canopies, and Accessory Car Wash Facilities

660-41.A APPLICABILITY

The regulations of this section apply to motor vehicle fuel pumps, canopies, and accessory car wash facilities. They do not apply to electric vehicle charging equipment.

660-41.B WHERE ALLOWED

The accessory structure tables for each building type in Article 3 identify the zones in which fuel pumps are allowed.

660-41.C PRINCIPAL BUILDING

Fuel pumps must be accessory to a (principal) building type allowed in the subject zone. Fuel pumps on sites without a principal building may be approved in accordance with the special exception procedures of 660-110.

660-41.D LAYOUT AND SETBACKS

Fuel pumps must be placed to ensure that all vehicle servicing will occur outside the public right-of-way. Fuel pumps must be setback at least 12 feet from all lot lines.

660-41.E ADDITIONAL REGULATIONS

- (1) **Separation from Schools and Residential.** No fuel pumps are allowed to be located within 200 feet of a primary or secondary school or within 50 feet of a dwelling unit. Separation distances are measured in a straight line from the fuel pump to the school building or building occupied by a dwelling unit.
- (2) **Height.** Fuel pump canopies may not exceed 18 feet in height.
- (3) **Materials.** Columns and supports must be clad in a major material used on the principal building facade.
- (4) **Car Wash Facility.** Car wash facilities are allowed as accessory uses to fueling stations. If detached from the principal building, they are regulated as outbuildings (see 660-43).

660-42 Home Occupations

660-42.A APPLICABILITY

The regulations of this section apply to home occupations, which are jobs or professions conducted as an accessory use to an allowed household living use.

660-42.B PURPOSE

The home occupation regulations of this section are intended to allow residents to engage in customary home-based work activities, while also helping to ensure that neighbors are not subjected to adverse operational and land use impacts (e.g., noise levels, traffic patterns or public safety hazards) that are not typical of residential neighborhoods.

660-42.C TYPES OF HOME OCCUPATIONS

These regulations establish 2 types of home occupations: type 1 home occupations and type 2 home occupations.

- (1) **Type 1.** Type 1 home occupations are those that meet the definition and criteria of a "no-impact home-based business" under the Pennsylvania Municipalities Planning Code.
- (2) **Type 2.** Type 2 home occupations are those in which household residents use their home as a place of work and in which either employees or customers come to the site. Typical examples include tutors, teachers,

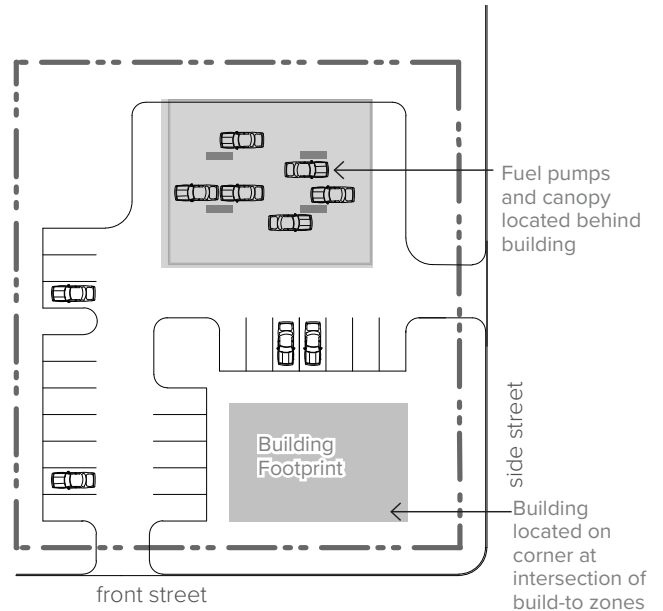

Figure 660(7) Fueling Pump Location

barbers, stylists, photographers, counselors, real estate agents, and offices of a medical, dental, chiropractic or similar doctor. Type 2 home occupations on lots with frontage on an arterial street or mixed-use corridor are permitted as of right. All other Type 2 home occupations require special exception approval.

660-42.D EXEMPTIONS

Nonresidential uses that are expressly allowed in conjunction with residential uses (e.g., bed and breakfast inns, family child care homes, and group child care homes) are not subject to home occupation regulations but are subject to all applicable permitting requirements.

660-42.E ALLOWED USES

The home occupation regulations of this section establish performance standards for all home occupations rather than listing specific uses and activities allowed to be conducted as part of a home occupation.

660-42.F PROHIBITED USES

The following uses are expressly prohibited as home occupations:

- (1) Any type of assembly, cleaning, maintenance, painting or repair of vehicles or equipment with internal combustion engines or of large appliances (such as washing machines, clothes dryers or refrigerators);
- (2) Dispatch centers or other businesses where employees come to the site and are dispatched to other locations;
- (3) Equipment or supply rental businesses;
- (4) Taxi, limo, van or bus services;
- (5) Tow-truck services;
- (6) Restaurants;
- (7) Funeral or interment services;
- (8) Animal care, shelter or boarding establishments;
- (9) Commercial food preparation;
- (10) Any use involving the use or storage of vehicles, products, parts, machinery or similar materials or equipment outside of a completely enclosed building; and
- (11) Any home-based work activity that does not comply with regulations of this section.

660-42.G TYPE 1 HOME OCCUPATIONS

Type 1 home occupations are allowed as of right as an accessory use to a principal use in the household living use category. Type 1 home occupations are subject to the following regulations:

- (1) Type 1 home occupations must be accessory and subordinate to the principal residential use of the property and may not occupy more than 25% of the gross floor area of the principal building, whether the type 1 home occupation is located in the principal residential building, an accessory building, or both.
- (2) No clients, customers, patients, or students are allowed in conjunction with a type 1 home occupation.
- (3) Only residents of the dwelling in which the type 1 home occupation is located may be engaged in a type 1 home occupation use. No nonresident owners, employees or contractors may be present on the property.

- (4) Type 1 home occupations may not produce light, noise, vibration, or odor perceptible beyond the property lines of the subject lot.
- (5) A maximum of one commercial vehicle may be parked on or adjacent to a lot on which a type 1 home occupation is located.
- (6) External structural alterations or site improvements that change the physical residential form of the building occupied by a type 1 home occupation are prohibited. Examples of such prohibited alterations include the addition of commercial-like exterior lighting and the addition of a separate building entrance that is visible from abutting streets.
- (7) No outdoor display of any material or merchandise is allowed in conjunction with a type 1 home occupation.
- (8) The use or storage of hazardous substances is prohibited, except at the “consumer commodity” level, as that term is defined in 49 C.F.R. Sec. 171.8.
- (9) Type 1 home occupations and all related activities must be conducted entirely within the principal residential building or an allowed accessory building.
- (10) Deliveries or pickups of supplies or products associated with a type 1 home occupation are limited to those normally serving residential neighborhoods.
- (11) More than one type 1 home occupation is allowed, but the type 1 home occupation regulations of this section apply to the combined type 1 home occupation uses.

660-42.H TYPE 2 HOME OCCUPATIONS

Type 2 home occupations are permitted as of right as an accessory use to a principal use in the household living use category if the subject lot has frontage on an arterial street. Type 2 home occupations are allowed on lots without frontage on an arterial street only if approved in accordance with special exception procedures of 660-110. All type 2 home occupations are subject to the following regulations.

- (1) Type 2 home occupations must be accessory and subordinate to the principal residential use of the property and may not occupy more than 25% of the gross floor area of the principal building, whether the type 2 home occupation is located in the principal residential building, an accessory building, or both.
- (2) At least one individual engaged in the type 2 home occupation must reside in the dwelling unit in which the type 2 home occupation is located as their primary place of residence.
- (3) A maximum of 2 nonresident employees are allowed with a type 2 home occupation. For the purpose of this provision, the term “nonresident employee” includes an employee, contractor, business partner, co-owner or any

other person affiliated with the home-based business, who does not live at the site, but who visits the site as part of the home-based business.

- (4) Customers or clients may visit the site only from 8:00 a.m. to 8:00 p.m. and by appointment only, with appointments limited to no more than one per hour. No more than 2 clients or customers may be present at any one time, except that up to 3 students may be present at one time in a teaching-related home occupation (e.g., tutor or music/dance instructor). Limitations on patient visits do not apply to offices of a medical, dental, chiropractic or similar doctor unless imposed at the time of special exception approval.
- (5) Face-to-face or walk-in retail sales activities are prohibited as a principal type 2 home occupation activity. Any face-to-face or walk-in retail sales of goods must be entirely accessory to any services provided on the site. This retail sales restriction is not intended to prohibit on-line retail sales.
- (6) Type 2 home occupations may not produce light, noise, vibration, or odor perceptible within the subject building or beyond the property lines of the subject lot.
- (7) External structural alterations or site improvements that change the physical residential form of the building or occupied by a type 2 home occupation are prohibited. Examples of such prohibited alterations include the addition of commercial-like exterior lighting and the addition of a separate building entrance that is visible from abutting streets.
- (8) Any tools or equipment used as part of a type 2 home occupation must be operated in a manner or sound-proofed so as not to be audible beyond the lot lines of the subject property.
- (9) The use or storage of hazardous substances is prohibited, except at the "consumer commodity" level, as that term is defined in 49 C.F.R. Sec. 171.8.
- (10) Type 2 home occupations and all related activities, including storage (other than the lawful parking of passenger vehicles), must be conducted entirely within the principal residential building or an allowed accessory structure.
- (11) Deliveries or pickups of supplies or products associated with a type 2 home occupation are limited to those normally serving residential neighborhoods.
- (12) Any personal improvement services that require a Pennsylvania state-issued license, must have licensed personnel on the premises during any hours when the use is open to the public
- (13) No more than one type 2 home occupation is allowed on a single property.

660-43 Outbuildings

660-43.A APPLICABILITY

The regulations of this section apply to outbuildings.

660-43.B DESCRIPTION

Outbuildings are completely enclosed, accessory buildings that are detached from the principal building. Typical outbuildings include detached garages and carports, sheds, barns, workshops, greenhouses, and detached accessory dwelling units. Note: Parking garages with more than one level or floor of parking are considered and regulated as "parking structures" (see 660-46).

660-43.C WHERE ALLOWED

The accessory structure tables for each building type in Article 3 identify the zones in which outbuildings are allowed.

660-43.D ALLOWED USE

Outbuildings may be occupied by any allowed accessory use.

660-43.E NUMBER

On lots less than 15,000 square feet in an N zone, the number of outbuildings on the lot is limited to two.

660-43.F SITING

The parking and accessory structure tables for each building type in Article 3 establish siting and setback regulations for outbuildings.

660-43.G HEIGHT

- (1) Outbuildings may not exceed 2 stories in height or the height of the principal building, whichever is less.
- (2) Floor-to-floor height regulations applicable to the principal building on the lot apply to outbuildings.

660-43.H UTILITIES

Any water or wastewater service for an outbuilding must be tied to the principal building on the lot. Separate water and wastewater connections serving outbuildings are prohibited.

660-44 Outdoor Display

660-44.A APPLICABILITY

The regulations of this section govern outdoor display, as defined in 660-141.

660-44.B REGULATIONS

The following regulations apply to all outdoor displays:

- (1) Outdoor displays are subject to all applicable setback regulations that apply to the principal building unless otherwise expressly stated in this zoning ordinance.
- (2) Outdoor displays on corner lots must be confined to a single frontage.

- (3) Merchandise or other items may be displayed only during hours of operation of the principal use.
- (4) Outdoor display areas may not interfere with pedestrian or automobile traffic on the subject lot or on public rights-of-way, and may not interfere with the enjoyment or operation of adjacent properties and uses.

660-45 Outdoor Storage

660-45.A DESCRIPTION

The regulations of this section govern outdoor storage, as defined in 660-141.

660-45.B WHERE ALLOWED

The key accessory structure tables for each building type in Article 3 identify the zones in which accessory outdoor storage areas are allowed.

660-45.C REGULATIONS

The following regulations apply to all outdoor storage areas:

- (1) Outdoor storage areas are subject to all applicable setback regulations that apply to the principal building unless otherwise expressly stated in this zoning ordinance.
- (2) Outdoor storage areas count toward maximum building coverage limitations.
- (3) All materials or wastes stored outdoors that cause fumes or dust or that constitute a fire hazard or that may be edible by or otherwise attractive to rodents or insects must be stored in closed containers.
- (4) All outdoor storage areas must be enclosed by a durable, permanent fence that is at least 6 feet in height and maintained to prevent any unauthorized access. Such outdoor storage area must be screened from view of streets and neighborhood zones in accordance with the frontage buffer and side and rear buffer regulations of Article 7.

660-46 Parking Structures

660-46.A APPLICABILITY

The regulations of this section apply to stand-alone, accessory structures occupied by decked, multi-level motor vehicle parking.

660-46.B WHERE ALLOWED

The accessory structure tables for each building type in Article 3 identify the zones in which parking structures are allowed and the siting requirements for such structures.

660-46.C ADDITIONAL REGULATIONS

- (1) **Setbacks.** Parking structures may not be located closer to any street or interior side lot line than the principal structure.
- (2) **Facade Design.** Accessory parking structures on street frontages must meet the parking structure facade design regulations 660-59.D.

660-47 Pigeon Keeping

660-47.A APPLICABILITY

The regulations of this section apply to pigeon coops maintained as an accessory use.

660-47.B REGULATIONS

- (1) Pigeon coops may not be attached to any structure or be placed on the roof of any structure.
- (2) Pigeon coops must be located in the rear yard and be set back at least 25 feet from all side and rear property lines.
- (3) Pigeon coops may not exceed 100 square feet in area.
- (4) Pigeon coops must be completely enclosed with wire netting or equivalent material that will prevent pigeons from escaping.

660-48 Rooming and Boarding

A maximum of one person may be fed and/or sheltered for profit as boarders or roomers as an accessory use to a household living use in N4 and N5 zones and a maximum of 2 persons may be fed and/or sheltered for profit as boarders or roomers as an accessory use to a household living use in any other N zone, provided that such boarders or roomers are limited to the principal dwelling unit that is owner-occupied.

660-49 Small Wind Energy Conversion Systems

660-49.A APPLICABILITY

The regulations of this section govern accessory small wind energy conversion systems.

660-49.B WHERE ALLOWED

Small wind energy conversion systems are allowed as an accessory use to a lawfully established principal use in all zones, provided that such systems comply with all applicable regulations of this section.

660-49.C HEIGHT

In N zones the height of an accessory small wind energy conversion system may not exceed the height of the principal building on the lot by more than 12 feet. The lowest point of any moving elements, such as blades or vanes,

must be at least 10 feet above the ground level immediately beneath the moving element.

660-49.D SITING

Small wind energy conversion systems are subject to the setback regulations that apply to principal buildings. In addition, systems must be set back from all property lines by a distance at least equal to 2 times the overall height of the system, measured from grade at the base of the structure to the highest point of the system structure, which includes the tip of the top blade when the blade is in its highest position.

660-49.E SOUND LEVELS

Small wind energy conversion systems are subject to the noise regulations of Chapter 400.

660-49.F DESIGN AND OPERATION

All small wind energy conversion systems must be equipped with manual and automatic over-speed controls to limit the blade rotation speed to within the design limits of the system.

- (1) The rotating turbine may not produce vibrations that are perceptible to humans standing at ground level outside the property lines of the subject lot.
- (2) Lattice-type towers and towers using guy wires are prohibited.
- (3) All power transmission and telemetry lines from a ground-mounted small wind energy conversion system to any building or other structure must be placed underground.
- (4) The system must include automatic devices to address high-speed winds, such as mechanical brakes and over-speed controls.
- (5) Towers, rotors and turbines may not be illuminated unless required by a state or federal agency, such as the FAA.
- (6) All structures and equipment must maintain factory colors or be finished in a non-reflective, matte finished, neutral color.
- (7) No commercial messages may be placed or painted on the tower, rotor, turbine, generator or tail vane that is legible from off-site. This provision is not intended to prohibit warning signs or manufacturer's logos.
- (8) All climbing pegs, ladders and similar apparatus on ground-mounted small wind energy conversion systems must be located at least 12 feet above the ground at the base of the structure.
- (9) The owner of the facility must completely remove all above-ground structures within 12 months after the system is no longer used to generate electricity.

- (10) Plans for minimizing bird and bat collisions with wind turbines through careful siting, blade design/color, and operational procedures (e.g., curtailment) must be submitted with the special exception application, or if special exception approval is not required, with the zoning permit application.

660-50 Solar Energy Systems

660-50.A APPLICABILITY

The regulations of this section govern accessory solar energy systems.

660-50.B GENERAL

- (1) Solar energy systems are permitted as an accessory use to all lawfully established principal uses in all zones.
- (2) Accessory solar energy systems must comply with all applicable building and electrical code requirements.

660-50.C BUILDING-MOUNTED SYSTEMS

- (1) Building-mounted solar energy systems may be mounted on principal or accessory structures.
- (2) Building-mounted solar energy systems may not encroach into required street setbacks. Systems mounted on principal structures may encroach into interior side setbacks by up to 2 feet and into rear building setbacks by up to 5 feet.
- (3) Only building-integrated or flush-mounted solar energy systems may be installed on street-facing building elevations.
- (4) Building-mounted solar energy systems may exceed the zone's maximum building height by up to 10 feet.
- (5) Systems must be constructed and installed so as not to emit glare onto adjoining properties.
- (6) Solar energy systems must be completely removed from the property within 6 months after they are no longer used for energy production.

660-50.D GROUND-MOUNTED SYSTEMS

- (1) In N zones, ground-mounted (freestanding) solar energy systems may not be located in a street yard.
- (2) Ground-mounted solar energy systems may be located within interior and rear yard areas but must be set back at least 2 feet from all lot lines.
- (3) Ground-mounted accessory solar energy systems may not exceed 18 feet in height.

660-51 Temporary Uses and Structures

660-51.A YARD SALES

- (1) Yard sales are sometimes referred to as "garage sales," "estate sales," "moving sales," "occasional sales,"

and other similar names. All such sales, by whatever name, are classified and regulated as “yard sales” in accordance with the regulations of this subsection.

- (2) Yard sales at properties occupied by principal residential uses are limited to 4 per calendar year. Each such yard sale is limited in time to no more than the daylight hours of 3 consecutive days.
- (3) No sign or other form of advertisement may be displayed for more than 24 hours before the commencement of such a sale and such signs must be removed immediately upon the conclusion of the sale.

660-51.B TEMPORARY OFFICES

- (1) **General.** The zoning officer is authorized to issue a temporary permit for routine and incidental temporary offices (e.g., real estate sales, construction and contractor offices), parking and storage areas that are necessary as part of active construction on the same site or an adjacent lot, or for a temporary real estate office on a site where 10 or more dwelling units are actively being offered for sale.
- (2) **Agreement.** Such temporary permit may be issued only if the owner provides a written and signed agreement to remove all such structures and activities after the completion of construction, or completion of sales in the case of a real estate office.
- (3) **Time Limit.** Such temporary permits may be issued for a period not to exceed one year, and may be renewed for one additional year if good cause is shown by the applicant in writing. After the first 2 years, a temporary use or structure may only continue to be permitted under a temporary permit if approval is received from the zoning hearing board.

[page intentionally blank]

ARTICLE 6. BUILDING DESIGN

660-52	Applicability	6-2
660-53	Intent	6-2
660-54	Original Design Elements	6-2
660-55	Roof Types	6-2
660-56	Towers	6-5
660-57	Entrance Types	6-6
660-58	Facade Materials	6-8
660-59	Facade Elements	6-10
660-60	Mechanical Equipment	6-12
660-61	Downtown High-Rise Stories	6-13

660-52 Applicability

The regulations in this article apply to new buildings and additions to existing buildings for all building types in all zones, except the following:

660-52.A WORKSHOP BUILDING

Workshop buildings in any IG or IM zone are exempt from the building design standards in this [Article 6](#).

660-52.B N3, N4, AND N5 ZONES

Buildings in any N3, N4, or N5 zone are exempt from the building design standards in this [Article 6](#).

660-52.C OTHER DESIGN STANDARDS

All efforts must be made to comply with any discretionary standards in this article as well as any other City-adopted design guidelines or standards for the area. Where conflicts exist between any regulations in this ordinance and the design guidelines outside this ordinance, the regulations of this ordinance apply.

660-53 Intent

The regulations of this article, [Article 6](#), along with the building type regulations in [Article 3](#), are intended to improve the physical quality of buildings, improve the long-term value and durability of buildings, enhance the pedestrian experience, and protect the historic form and scale of the city.

660-54 Original Design Elements

660-54.A EXISTING ELEMENTS

Any permanent design element original to the building and constructed prior to the day before the effective date specified in [660-01.C](#) that does not conform with these regulations may be retained, except where that design element is being significantly revised or completely replaced.

660-55 Roof Types

Each major component of any roof should meet the requirements of one of the roof types permitted per the building type regulations in [Article 3](#).

660-55.A REGULATIONS APPLICABLE TO ALL ROOF TYPES

- (1) Roofs for bay or bow windows and dormers are not required to meet a roof type.
- (2) Terraces, green roofs, rooftop gardens, and other outdoor facilities are allowed on any roof and are not considered a roof type, except as follows:

- (a) Any permanently roofed, open-air area applies to the overall height as regulated by the building type regulations ([Article 3](#)), or may be treated as an interior building tower per [660-56](#).
 - (b) Any fully enclosed structure on a roof should meet the tower regulations per [660-56](#).
 - (c) Where any canopy or cover is visible from any public way or open space, the cover should comply with a roof type per this section, [660-55](#).
- (3) Roofs, including all eaves or overhangs, should be fully located within the property lines of the lot, unless otherwise stated in [660-126.G](#), allowed encroachments into yards. See [Article 3](#) for setback regulations.

660-55.B OTHER ROOF TYPES

Other roof designs not defined in this section may be approved through the special exception process per [660-110](#).

660-55.C PARAPET ROOF TYPE

A parapet is a low wall projecting above a building's roof along the perimeter of the building on all street facades and other front facades. See [Figure 660\(10\)](#) Example of a Parapet Roof.

- (1) **Parapet Height.** Height is measured from the top of the upper story to the top of the parapet.
 - (a) Minimum height is 1.5 feet with a maximum height of 6 feet.
 - (b) A shadow line should be located within 2 feet of the top of the uppermost story. See [660-145](#) for definition of shadow line.
 - (c) A shadow line should be located at the top of the parapet. See [660-145](#) for definition of shadow line.
- (2) **Rooftop Appurtenances.** With the exception of solar panels and wind turbines, any rooftop appurtenances should be located towards the rear or interior of the parapet roof. Rooftop appurtenances should be located such that the parapet blocks their view from the sidewalk across the street or may be located within a tower per [660-56](#).

660-55.D FLAT ROOF TYPE

This roof type is a visibly flat roof with overhanging eaves or a cornice along front street facades. See [Figure 660\(11\)](#) Example of a Flat Roof.

- (1) **Maximum Slope.** The maximum slope is 2:12; however, the roof should not appear to be visibly sloped from the front street or other front frontages. See [Figure 660\(8\)](#).
- (2) **Street Facades.** For this roof type, either eaves on all street facades, or a cornice should be included on the

front facade with a shadow line and cap on any other street facade.

- (3) **Eaves.** The following applies to street facade eaves:
 - (a) **Eave Depth.** Eaves should have a minimum depth of at least 14 inches. Eave depth is measured from the building facade to the outside edge of the eave.
 - (b) **Eave Thickness.** Eaves should be a minimum of 6 inches thick. Eave thickness is measured at the outside edge of the eave, from the bottom of the eave to the top of the eave.
- (4) **Cornice.** The following applies to front street cornice:
 - (a) **Cornice Length.** The cornice should extend the full length of the front street facade.
 - (b) **Cornice Size.** Cornices should be a minimum of 15 inches deep and 15 inches in height.
 - (c) **Cornice Materials.** The cornice should be constructed as a 3-dimensional element, consisting of cast stone, masonry, marine-grade fiberglass, glass fiber reinforced concrete, composite stone, metal, wood, polyurethane, or natural stone.
- (5) **Rooftop Appurtenances.** With the exception of solar panels and wind turbines, rooftop appurtenances should not be located on the flat portion of this roof type. Rooftop appurtenances should be located centrally on the roof such that their view is minimized from the street or may be located within a tower per 660-56.

660-55.E PITCHED ROOF TYPE

This roof type is a sloped or pitched roof, where the slope occurs on all street and other front facades. Slope is measured with the vertical rise divided by the horizontal span or run. See Figure 660(9) Examples of Pitched Roof type.

- (1) **Pitch Measure.** The roof should not be sloped less than a 4:12 (rise:run) or more than 14:12, unless otherwise expressly stated. See Figure 660(8).
- (2) **Hipped or Gabled Roofs.** Hipped, gabled, and combination of hips and gables with or without dormers are allowed.
 - (a) When the ridge line runs parallel to any front street, one of the following should occur except as otherwise stated in the building type regulations:
 - [1] A gabled end or perpendicular ridge line should occur at least every 100 feet of roof; or
 - [2] One dormer should be provided for every 15 feet of ridge line on any street or front frontage with at least one dormer per frontage.

- [3] A bay with a separate roof on the front street facade or a tower per 660-56, as allowed by building type.
 - (b) Occupied building space within the roof is allowed and counts as a half or full story. See 660-126.M for definition of half story and any half story limitations per the building type regulations. See 660-141 for definition of occupied building space.
 - (c) **Maximum Roof Height.** Pitched roofs with a ridge parallel to the front street and without occupied building space should have a maximum height on street facades equal to no more than 1.5 times the upper story floor-to-floor height utilized on the building.
- (3) **Gambrel or Mansard Roof.** Gambrel and mansard roofs should include the following:
 - (a) Gambrel roofs with the ridge parallel to the street and mansard roofs should include one dormer is provided for every 15 feet of ridge line on any street or other front with at least one dormer per frontage.

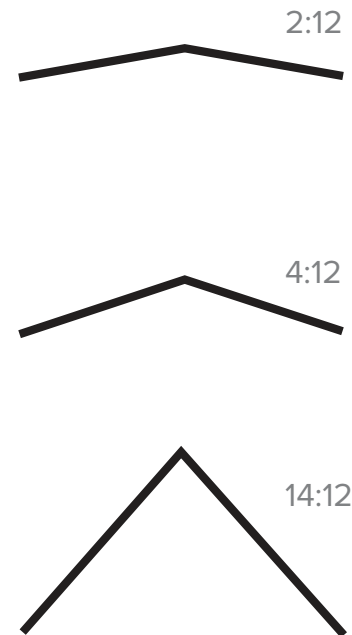

Figure 660(8) Diagram of Roof Pitches



Pitched Roof Type (Gable Roof)



Pitched Roof Type (Gable Roof)

Figure 660(10) Examples of Parapet Roof Types



Pitched Roof Type (Hipped Roof)



Flat Roof Type (with Cornice)



Pitched Roof Type (Gambrel Roof)



Flat Roof Type (with Eave)



Pitched Roof Type (Mansard Roof)

Figure 660(11) Examples of Flat Roof Types

Figure 660(9) Examples of Pitched Roof Types

- (b) The steepest portion of the roof should be no greater than the tallest permitted height of one upper story.
- (c) Occupied building space should be included beneath the roof and counts as a half or full story. See 660-126.M for definition of half story. See 660-141 for definition of occupied building space.

(4) Rooftop Appurtenances. With the exception of solar panels, antennae, and wind turbines, any rooftop appurtenances, where feasible, should be located on the rear sloping portion of the roof to limit visibility from the street.

660-56 Towers

A tower is an enclosed, vertical element that may be used with other roof types. See Figure 660(12) Example of Tower.

660-56.A QUANTITY

Unless otherwise defined in the building type regulations, the following is allowed:

- (1) Street Facade Towers.** A maximum of 2 towers located within 15 feet of any A or B street facade is permitted on any building. Street facade towers enhance the facade design.
- (2) Interior Building Towers.** Two additional towers are permitted provided the towers are located a minimum of 30 feet from any street facade. Interior towers are typically functional, providing housing for utilities or access to the roof.

660-56.B TOWER HEIGHT.

- (1)** Maximum height, measured from the top of the uppermost of the building to the top of the tower shaft, not including the tower roof, is the equivalent of the height of one upper floor of the building to which the tower is applied.
- (2)** A tower allows for up to one additional story of height within the tower footprint to any building type where permitted.

660-56.C TOWER FOOTPRINT.

The maximum width in any direction of the footprint of any tower is 1/3 the width of any street or other front facade or 30 feet, whichever is less.

660-56.D TOWER SPACING

Street facade towers, within 15 feet of any street facade, should be spaced a minimum of 120 feet from other street facade towers. Interior building towers must be located a minimum of 60 feet from any other tower.

- (1) Transparency.** Towers that meet the minimum floor-to-floor height of the building type and are located within

30 feet of a street facade should meet the minimum front facade transparency requirements of an upper story of the building type to which the tower is applied.



Figure 660(12) Example Towers Extending above Roofline

660-57 Entrance Types
.....

Entrance types provide the transition between the public sidewalk in front of the building into the ground story of the building. Each front entrance should meet the requirements of one of the entrance types permitted per the building type regulations in Article 3.

660-57.A STOREFRONT ENTRANCE TYPE

Storefront entrance types are intended to provide at or close to grade access between the storefront and adjacent sidewalk creating a high level of permeability. See Figure 660(13).

660-57.B STOOP ENTRANCE TYPE

A stoop is a small, open platform that may include a permanent canopy or roof cantilevered off the building. See 660-59.B for principal entryway standards. See Figure 660(14).

(1) Right-of-Way Encroachment. Where buildings are located within 5 feet from the front lot line, an encroachment permit may be applied for from the City to approve encroachment into the public right-of-way.

660-57.C PORCH ENTRANCE TYPE

A porch is a raised, platform with a perimeter railing or wall and a porch supported by columns, that may or may not be enclosed on all sides. See Figure 660(15).

- (1) Transparency.** If a porch is enclosed, each exterior porch wall must meet a minimum transparency of 70%.
- (2) Porch Size.** The porch should be a minimum of 5 feet deep and 8 feet wide.
- (3) Height.** Porches should meet the minimum and maximum story height for the building type.



Storefront Entrance Type (at Grade)



Porch Entrance Type



Storefront Entrance Type (Elevated with Platform)



Porch Entrance Type (Elevated)

Figure 660(13) Example of a Storefront Entrances

Figure 660(15) Examples of Porch Entrances



Stoop Entrance Type (Encroaching into R.O.W.)



Stoop Entrance Type (at Grade)



Stoop Entrance Type (with Canopy)



Stoop Entrance Type (with Expanded Storefront Glass)

Figure 660(14) Examples of Stoop Entrances

660-58 Facade Materials

660-58.A STREET FACADE MATERIALS

Major facade materials are listed in Table 660-6.

- (1) **Street and Other Front Facades.** At least 65% of Major facade materials are required on all A and B street and other front facades, unless otherwise stated, must be composed of major facade materials and are intended to serve as the primary surface material on those facades. See 660-12.J for other front facades.
- (2) **Original Facade Materials.** Where brick, stone, or terracotta is an existing building's original facade material, the following applies:
 - (a) The original material may be maintained if in good condition or repaired, or the original material may be replaced by new, full-dimensional brick, natural stone, or terracotta.
 - (b) No material, including brick or stone veneer, may be installed over the original brick or stone.
- (3) **Minor Materials for Street Facades.** The remaining portions of all A or B street or other front facade surface, not including window and door areas, may be composed of other high quality, durable facade materials.

660-58.B APPROPRIATE GRADE OF MATERIALS

All doors, windows, and hardware must be of commercial grade quality with the exception of those on Rowhouse, Twinhouse, and House buildings.

660-58.C OTHER MATERIALS

Materials that are not listed in this section as allowed major, minor, accent/detail, or roof materials may be approved by the zoning officer, provided the material is equivalent to any material allowed or the material exists as a major material on more than 50% of other buildings on the subject blockface. The zoning officer may require the submission of manufacturer cut sheets and material samples to determine the equivalent status of the proposed material.

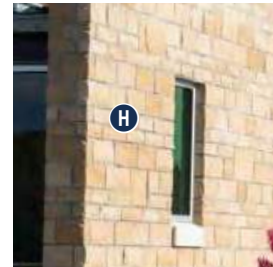
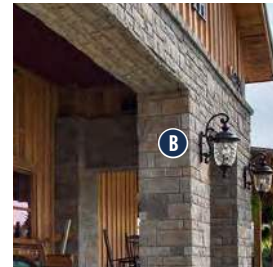

Table 660-6. Allowed Major Facade Materials on Street & Other Front Facades

MAJOR FACADE MATERIAL (alphabetical)	BUILDING TYPES					
	STOREFRONT, GENERAL BUILDINGS IN MX-D & GX-D	STOREFRONT, GENERAL & SMALL GENERAL BUILDINGS	COMMERCIAL CENTER	TOWN, URBAN ROWHOUSE; TWINHOUSE, HOUSE A	LANE ROWHOUSE, SUBURBAN ROWHOUSE	WORKSHOP, CIVIC BUILDING
A Brick full dimensional, unit, face brick, unglazed, no black	●	●	●	●	●	●
B Concrete Masonry Units architectural, minimum 3 inch depth, “artisan stone” look, varied sizes, “stone” face, “hewn stone”, rock cut	●	●	●	●	●	●
C Fiber Cement Board finished lap siding, board & batten, or shingles	● only on 4th story or higher and not allowed on buildings abutting Hamilton Street	● only on buildings 3 stories in height or less	●	–	●	●
D Fiber Cement Board panels	● only on 4th story or higher and not allowed on buildings abutting Hamilton Street	● only on buildings 3 stories in height or less	●	–	●	●
E Glass curtain wall	●	–	–	–	–	●
F Metal, Architectural articulated architectural panel, cladding system (steel, titanium, zinc, corten steel)	●	–	●	–	–	●
G Metal, Aluminum Composite aluminum composite materials (ACM) or panels (ACP)	–	–	–	–	–	●
H Stone natural, units	●	●	●	●	●	●
I Stucco cement-based, 2-3 layer hard coat	●	●	●	–	●	●
J Terra Cotta or Ceramic tiles or panels	●	●	●	●	●	●
K Vinyl & PVC Siding minimum .04 in. thick	–	–	–	–	●	–
L Wood or Composite Wood painted, stained, charred, or treated lap siding, shingles, board & batten, rainscreen	–	–	–	–	●	–

NOTE: MATERIALS MAY NOT APPLY IN HISTORIC DISTRICTS. SEE CHAPTER 328.

KEY: ● = allowed – = prohibited

660-59 Facade Elements

660-59.A SECURITY GRILLES & BARS

- (1) Exterior bars and security grilles are prohibited on any street facade opening.
- (2) Security grilles must be fully retractable and located within the interior of the building. When retracted, the grilles may not be visible from the exterior of the building.

660-59.B PRINCIPAL ENTRYWAY

See Figure 660(20) for examples of defined principal entryways. Principal entrances to all buildings or units, except storefronts, must be visible from the street and clearly delineated through one or more of the following design features:

- (1) **Roof or Canopy.** The entryway is covered by a roof or canopy differentiating it from the overall building roof type.
- (2) **Porch.** The entryway is through a porch.
- (3) **Sidelights and Transom.** Sidelights or transom windows are included around the entryway.
- (4) **Articulation.** The entryway is included in a separate bay of the building that extends up at least 2 stories or in a recessed bay with a change in material.
- (5) **Other Methods.** Other structural methods of substantially differentiating the entrance from the facade similar in scope to the examples of this section, not including paint, trim, or materials.

660-59.C BUILDING ARTICULATION

See Figure 660(18) for examples of building facade variety. Buildings 120 feet in length or greater, as measured along any street frontage, must fulfill the following requirements:

- (1) **Building Variety.** Each street and other front facade shall be varied in segments less than or equal to 60 feet. Each facade segment must vary by at least 2 of the following:
 - (a) The type of dominant facade material or by color, scale, or orientation of that material;
 - (b) The proportion of recesses and projections within the build-to zone;
 - (c) The location of the entrance and window placement, unless storefronts are utilized;
 - (d) Roof type, plane, or material, unless otherwise stated in the building requirements;
 - (e) Building height.
- (2) **Articulation of Stories.** Stories shall be articulated on street and other front facades per the following:

- (a) **Fenestration.** Fenestration or window placement on street facades shall be organized by stories per the building type facade transparency regulations.
- (b) **Shadow Lines.** Horizontal shadow lines and lintels over openings may be used to delineate stories with minimum shadow lines required per building type.
- (c) **Mezzanines.** Mezzanines that fall within the range of floor to floor heights of the building type shall be articulated on the facade and require separate calculation for transparency per 660-126.N Tall Stories.
- (d) **Taller Spaces.** Spaces exceeding the allowable floor to floor heights of the building type shall be articulated as multiple stories on the street facade.

660-59.D PARKING STRUCTURE FACADES

Parking structure facades visible from any A or B street or other front shall meet the following standards. See Figure 660(16) for an illustration of a parking structure street facade.

- (1) **Materials.** Major and minor material requirements, per 660-58, must be met on all street and other front facades. An additional permitted minor material is stained, finished concrete.
- (2) **Ramps and Slopes.** Ramps and slopes may not be located on any A or B street facade or other front facade.
- (3) **Screening of Vehicles.** Visibility of parked motor vehicles must be screened from the street by walls, screens, or vegetation with a minimum opacity of 50%.
- (4) **Blank Wall Limitations.** No rectangular area greater than 30 percent of any story's facade, as measured from floor to floor, and no horizontal segment of a story's facade greater than 15 feet in width may be solid wall without an opening.
- (5) **Vertical Divisions.** Vertical divisions extending to the full height of the structure are required every 30 feet to deemphasize the horizontal decks. Divisions must be a minimum of 2 feet in width with a minimum projection of 1.5 inches.
- (6) **Entry Tower.** A pedestrian entrances directly into the parking structure from the street is required to be separate from the vehicular entrance and directly accessed from the sidewalk. The pedestrian entrance must meet the principal entryway regulations in 660-59.B. Stairwells must be located inside a tower per 660-56 with windows at a transparency rate of 65%.
- (7) **Roof Type.** The top story of the parking structure must include a parapet or other roof type along all street or

other front facades. Refer to roof types defined in 660-55.

- (8) Vehicular Entrances.** Driveways must be no wider than 22 feet and the entrance and exit should be split by a median. Access must be located on a side street, unless the lot does not abut a side street. No more than 2 access points shall be located on any one street, totaling no more than 24 feet of drives crossing any street sidewalk. See 660-64 for sight triangle regulations.
- (9) Openings.** All openings shall be treated in a manner that creates the appearance of an active use area, and conceals all internal elements such as plumbing, pipes, fans, ducts, and lighting.



Figure 660(17) Examples of Defined Principal Entryways

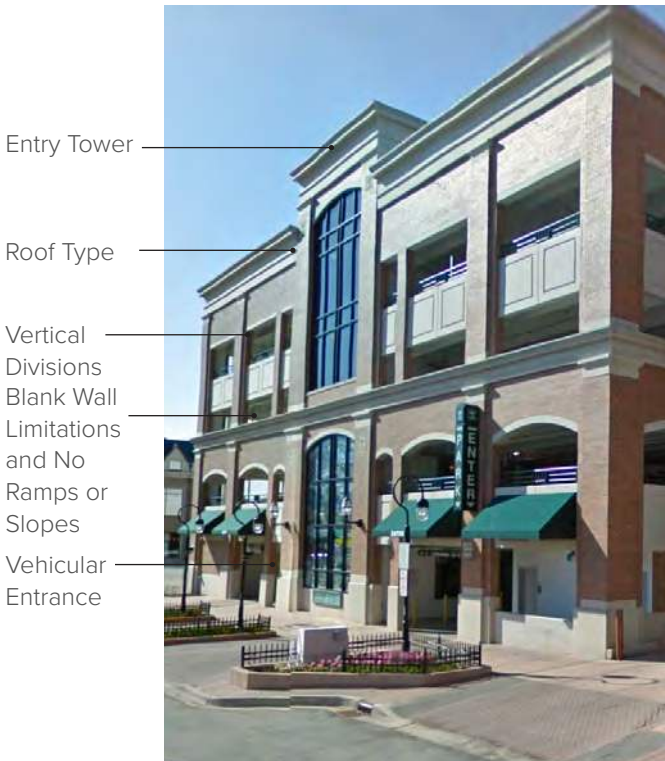

Figure 660(16) Example of a Parking Structure



Figure 660(18) Examples of Building Articulation

660-60 Mechanical Equipment

660-60.A PURPOSE

Mechanical equipment is necessary for any building design, but can have a negative visual impact and detract from the quality of the design of a building. The purpose of the regulations in this section, 660-60, is to ensure that the visual impact of mechanical equipment and appurtenances is minimized to the maximum extent feasible.

660-60.B "MECHANICAL EQUIPMENT" DEFINED

When the following regulations refer to "mechanical equipment," any mechanical equipment or utility appurtenance, such as but not limited to HVAC systems, boilers, condensers, transformers, generators, vents, meters, ducts, are being referenced, except wind and solar energy systems, subject to 660-49 and 660-50 in accessory structure regulations.

660-60.C EXISTING BUILDINGS

Buildings that exist prior to the effective date of these regulations in 660-01.C and are unable to meet the standards of this section are exempt from these regulations.

660-60.D MECHANICAL EQUIPMENT ON ROOFS

Any exterior rooftop mechanical equipment must be located consistent with one of the following methods. See Figure 660(25) for an example.

- (1) Incorporate equipment into the roof design consistent with the applicable standards of roof types in 660-55.
- (2) Set the equipment back a minimum of 15 feet from any street or public way facade.
- (3) To the extent practicable, all rooftop mechanical must be painted to blend with the structural roof and limit its visibility.

660-60.E MECHANICAL EQUIPMENT ON GROUND

Mechanical equipment, such as electrical transformers and air conditioners, located on the ground, decks, or horizontal surfaces other than the roof must be located consistent with the following standards:

- (1) **No Encroachment.** Mechanical equipment shall not extend into any right-of-way or any easement, unless otherwise approved by the city.
- (2) **Allowed Yard Location.** See 660-151 for definition of yards.
 - (a) **Front Street Yard.** Mechanical equipment and appurtenances should not be located in the front street yard.
 - (b) **Side Street Yard.** Mechanical equipment may be located in the side street yard only when the equipment cannot function or be located in a rear or

side yard, and provided the equipment is screened from the street per 660-60.E(3).

- (c) **Rear and Side Yard.** Mechanical equipment may be located in any rear or side yard.

- (3) **Screening from Streets, Open or Civic Spaces.** All equipment must be screened from view from any streets, open space, or civic space per one of the following:

- (a) Opaque walls for screening must be consistent with the building design, colors, and materials, faced with an allowed major facade material.
- (b) Combination of fencing and landscaping may be used, provided the fencing is taller than the equipment and does not exceed allowed heights per 660-39. Landscaping must combine with the fencing to create an opaque screen.
- (c) Where landscaping only is employed, the following must be met:
 - [1] The utility must be located in a larger landscape area and the landscape screen designed as part of the larger planting bed design.
 - [2] Evergreen shrubs must fully screen the equipment within 1 year of installation.
 - [3] The zoning officer may require additional landscape materials to fully screen the equipment.

660-61 Downtown High-Rise Stories

660-61.A APPLICABILITY

The standards in this section apply to the following:

- (1) Stories designated on the Storefront building type in the MX-D zone as high-rise stories per 660-14.G.
- (2) Stories designated on the General building type in the GX-D zone as high-rise stories per 660-15.G.
- (3) All other building type and design regulations apply.

660-61.B INTENT: BASE, MIDDLE, CAP

These requirements refer to building design by base, middle, and cap as defined in the following intent statements, with the goal of differentiating each building segment visually. See Figure 660(19).

- (1) **Base.** The base of a building is intended to establish an active ground story along the street and provide a public building face (such as a lobby, retail/service space, or restaurant) for all of the activities that occur within a building.

- (2) **Middle.** The middle section of the building (high-rise stories) is intended to be oriented to maximize light reaching the front street, to avoid the “walling off” of the front street along the entire length, and allow views to the sky from the street.
- (3) **Cap.** The cap of the high-rise includes the top few high-rise stories and the roof of the building, and is intended to be designed consciously to contribute to the city skyline per the requirements of this section, 660-61.

660-61.C BUILDING BASE REQUIREMENTS

The base requirements for the building shall follow the requirements of the building type, whether a Storefront or a General building, with the following additional requirements. See Figure 660(20).

- (1) **Build-to Zone.** The building base facade must meet the build-to zone regulations of the building type.
- (2) **Base Height.** The base shall be a minimum of 3 stories.

660-61.D BUILDING MIDDLE REQUIREMENTS

The middle of the building should meet any applicable regulations of the building type and the following:

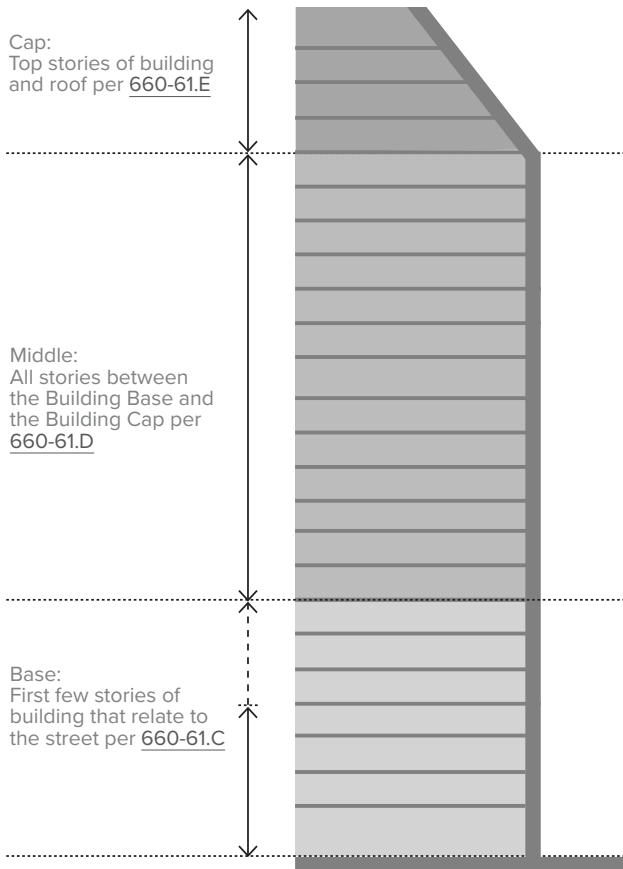

Figure 660(19) High-Rise Building: Base, Middle, Cap

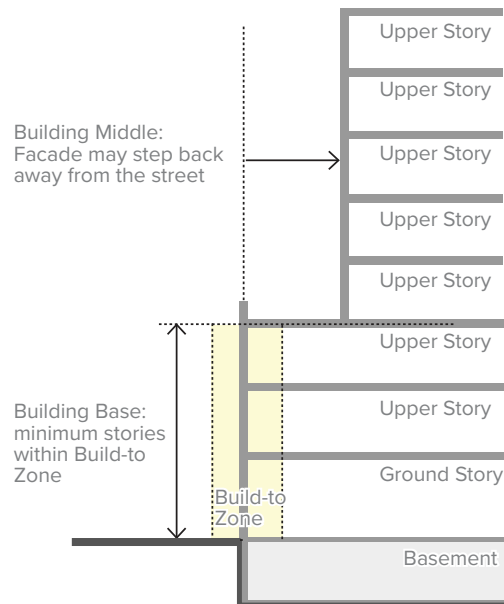

Figure 660(20) Building Massing in Build-to Zone

- (1) **Orientation.** To the maximum extent practicable, the building middle should be oriented with the shortest side parallel to a front street to avoid a continuous high-rise wall along the A street frontage above the building base. See [Figure 660\(21\)](#).
- (2) **Narrowest Widths.** High-rise buildings should utilize the narrowest widths economically feasible, to limit the mass of and shadows cast by the high-rise.
- (3) **Step-Back.** The facade of the middle of the building must step back away from any A or B street and required build-to zone, above the minimum base height. See [Figure 660\(20\)](#). If step-backs are not practicable, the building mass should be configured to allow extended views of the sky from the street and light and air to penetrate to the street.
- (4) **Peaks and Valleys in the Skyline.** Variation of the skyline of the downtown area is desirable and should be considered. For all buildings utilizing high-rise stories, the following applies:
 - (a) An illustration of the skyline, incorporating the subject building, must be submitted during the pre-application meeting.
 - (b) The surrounding building context shall be considered when determining the maximum building height.
- (5) **Multiple High-Rise Sections.** When more than one high-rise is utilized for a development, the heights of the multiple high-rise building sections should be varied to encourage development of an interesting skyline.

660-61.E BUILDING CAP REQUIREMENTS

The following applies to the cap of the building utilizing high-rise stories:

- (1) The high-rise portions of the building are exempt from the building type's roof type requirement.
- (2) Terraces, green roofs, gardens, and other outdoor facilities are encouraged to occur on rooftops of the base portion of the buildings.
- (3) The surrounding building context must be considered when determining the building cap. Variation is preferred.
- (4) The massing and/or material expression of the cap should define it distinctly from the middle of the building, including such elements as angles, larger openings, stepping, or distinctive windows.
 - (a) The cap design should consider the profile building in the top stories to increase visibility within the skyline.

- (b) The cap should be scaled to be apparent from longer distances.

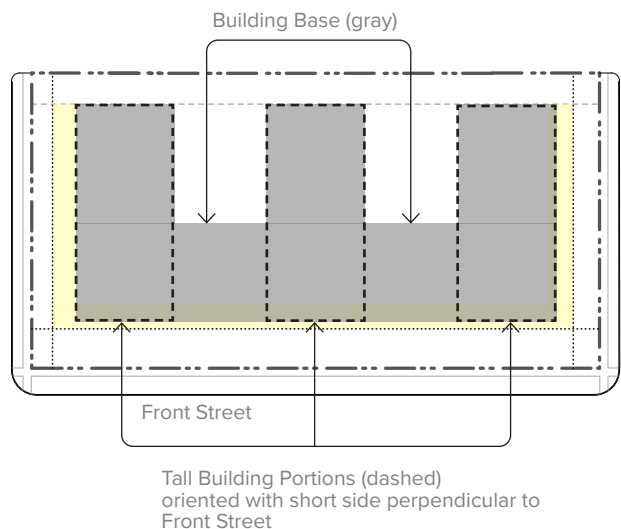

Figure 660(21) High-Rise Building Orientation

ARTICLE 7. SITE DESIGN

660-62 Applicability 7-2
660-63 Intent 7-2
660-64 Sight Triangles 7-2
660-65 Landscape Installation 7-3
660-66 General Landscape Maintenance 7-4
660-67 Existing Significant Trees 7-4
660-68 Ground Vegetation 7-5
660-69 Landscape for Large Street Yards 7-5
660-70 On-Site Walkways 7-6
660-71 Street Trees 7-6
660-72 Frontage Buffer 7-6
660-73 Side and Rear Buffers 7-8
660-74 Interior Parking Lot Landscape 7-11
660-75 Steep Slope Regulations 7-12
660-76 Soil-Disturbing Activities 7-14
660-77 Performance Standards 7-14

660-62 Applicability

The site design regulations of this article, Article 7, apply in the following situations:

660-62.A NEW DEVELOPMENT AND EXPANSIONS

New buildings constructed or enlargement of an existing building by more than 35% of its footprint and at least 2,500 square feet, unless otherwise stated in this article.

660-62.B NEW LANDSCAPE AND SITE ELEMENTS

New landscape and site development elements constructed that are regulated by this article, Article 7, such as tree removal, parking or loading areas, outdoor storage areas, and other vehicular areas (e.g. drive-through facilities, fueling stations, vehicular sales lots).

660-62.C ADAPTIVE REUSE

See 660-30.A(2)(a) for adaptive reuse of an existing building and supplemental use regulations requiring compliance with the site design regulations in this article, Article 7.

660-62.D EXPANSION OF EXISTING PARKING, LOADING AREAS, OR OTHER VEHICULAR AREAS

Whenever an existing parking, loading, or other vehicular area (e.g. drive-through facilities, fueling stations, vehicular sales lots) is enlarged or expanded by more than 2,500 square feet, parking lot landscape, frontage buffers, and side and rear buffers must be applied per this article.

660-62.E EXPANSION OF OUTDOOR STORAGE AND TRUCK TERMINAL USES

Whenever an existing outdoor storage or truck terminal use is expanded or enlarged by more than 500 square feet, frontage and side and rear buffers must be applied per this article.

660-63 Intent

The landscape and site design regulations of this article are intended to provide the following:

- (1) To protect property values and the appearance of neighborhoods and commercial zones through appropriate landscape and fencing.
- (2) To provide for healthy, long-lived trees within all public ways to improve the appearance of streets and create a buffer between pedestrian and vehicular travel lanes.
- (3) To increase the urban tree canopy throughout the city.
- (4) To increase the compatibility of adjacent uses and minimize the adverse impacts created by adjoining or neighboring uses.
- (5) To promote the prudent use of water through sustainable, functional landscapes.

- (6) To reduce energy demands through the shading of buildings and pavement, reducing urban heat island effects.

660-64 Sight Triangles

No walls, fences, plants, or trees may be constructed or planted to obstruct or eventually obstruct or hinder the visibility of drivers at the intersection of the street right-of-way lines and at driveways where they intersect streets.

660-64.A GENERALLY

- (1) **Unobstructed Visibility.** Unobstructed visibility must be maintained between 30 inches above curb level and 10 feet above curb level within the sight triangle areas defined in this section, 660-64.
- (2) **Obstructions.** Obstructions are defined as any structure, fence, wall, hedge, shrub, or other planting. Obstructions must not be constructed or planted to obstruct or eventually hinder or obstruct the visibility of drivers within the defined sight triangles.
- (3) **Sight Triangle Configuration.** The 3 sides of the sight triangles are defined along 2 rights-of-way, or a right-of-way and driveway pavement edge, with the third line of the triangle connecting those 2 lines.
- (4) **Rounded Corner.** In the case of a rounded property corner, the two shorter sides of the triangle shall be drawn from the intersection of the lot lines extended.

660-64.B SPECIFIC TRIANGLE DIMENSIONS

- (1) **Street Intersections.** At street intersections, no obstructions may be located within a sight triangle measured 15 feet from the intersection of the street along each street right-of-way line.
- (2) **Alley-Street Intersection.** The sight triangle at the intersection of an alley and street shall be measured 15 feet along the street right-of-way and 10 feet along the alley right-of-way
- (3) **Alley-Alley Intersection.** The sight triangle at the intersection of two alleys shall be measured 5 feet along each alley right-of-way
- (4) **Driveway-Street Intersection.** At the intersection between a street and a driveway, no obstruction shall be located within a sight triangle measured 10 feet along the street right-of-way and 10 feet along the driveway edge.

660-64.C EXCEPTIONS

The following are exceptions to the unobstructed sight triangles defined in this section.

- (1) Parcels located in any MX-D or GX-D zone are excepted from the sight triangle regulations.

- (2) A utility pole or a pole for a permitted sign may be located within a sight triangle provided it does not have a diameter greater than 20 inches.
- (3) A trunk of an existing tree may continue to be located in a sight triangle, provided the adjacent landowner trims the branches to minimize sight obstructions.
- (4) A support column may be located within the sight triangle, provided the column is of the minimum size necessary for structural support.
- (5) This section, 660-64, shall not, by itself, prevent the replacement of an existing principal building with a new principal building, provided that the new principal building does not intrude into the clear sight triangle to a larger extent than the pre-existing building and that a building permit is issued for such replacement within 12 months of the removal of the previous building.
- (6) A lot located at an intersection with a one-way street, where the lot is located such that visibility would not be obscured in any direction.

660-64.D LAND DEVELOPMENT & SUBDIVISION ORDINANCE

See also the land development and subdivision ordinance (Chapter 350 of the municipal code), which may require a larger sight triangle in the case of a new subdivision or other land development.

660-65 Landscape Installation

660-65.A INTENT

The following provisions aid in ensuring that all landscaping required by this ordinance is installed and maintained properly.

660-65.B APPLICABILITY

These provisions apply to any landscape installation required by this article.

660-65.C GENERAL INSTALLATION REQUIREMENTS

- (1) **National Standards.** Best management practices and procedures according to the nationally accepted standards must be practiced. All landscape and trees must be installed in conformance with the practices and procedures established by the most recent edition of the American Standard for Nursery Stock (ANSI Z60.1) as published by AmericanHort.
- (2) **Timing.** All landscape materials must be fully installed prior to the issuance of a certificate of occupancy.
 - (a) If seasonal conditions preclude the complete installation, a cash escrow or irrevocable letter of credit, equal to 1.5 times the installation costs as estimated by a qualified professional, is required.

- (b) Complete installation is required within 9 months of the issuance of the temporary certificate of completeness or occupancy permit or the cash escrow or letter of credit may be forfeited.
- (3) **Tree Measurement.** Caliper is the measured diameter (inches) of the tree trunk for trees to be installed as follows:
 - (a) Caliper measurement of the trunk must be taken 6 inches above the ground or top of the root ball up to and including 4 inch caliper size.
 - (b) If the caliper at 6 inches above the ground exceeds 4 inches, the caliper must be measured at 12 inches above the ground or top of the root ball.
- (4) **Plant Size Requirements.** Plant material must be sized according to Table 660-7 unless otherwise noted in this section.
- (5) **Condition and Selection of Planting Materials.** The plant materials used must be free from visible signs of disease, infestation, or physical defect at the time of planting.
 - (a) Plant materials must be appropriate for the conditions of the location, including sun and wind exposure, air quality, salt exposure, soil type, expected moisture content of soil, and slope.
 - (b) Plant materials must not be an invasive or a potentially invasive species.
 - (c) Plant materials are encouraged to be native or naturalized.
- (6) **Compost, Mulch, and Organic Matter.** Compost, mulch, and organic matter must be utilized within the soil mix to reduce the need for fertilizers and increase water retention.
- (7) **Establishment.** All installed plant material must be fully maintained until established, including watering, mulching, fertilizing, and replacement as necessary.

660-65.D PERMEABLE SURFACE AREA FOR TREES

For each tree planted, a sufficient amount of permeable surface area is required, unless otherwise stated in this ordinance, to ensure root growth and access to air and water.

- (1) **Minimum Area.** A minimum required permeable surface area of 24 square feet is required per tree unless the zoning officer or, in the public right-of-way, the Shade Tree Commission determines the minimum area is not practicable.
- (2) **Required per Tree.** Permeable area for one tree may not count toward that of another tree.

(3) Aeration Systems and Permeable Pavers. Other alternative surfacing and soil systems may be required by the zoning officer in situations where sufficient permeable surface area is not provided.

660-66 General Landscape Maintenance

660-66.A APPLICABILITY

All landscape required by this article must be maintained in healthy condition per this section, 660-66.

660-66.B GENERAL MAINTENANCE

- (1) National Standards.** All landscaping and trees must be maintained according to the most recent edition of the American National Standards Institute, including its provisions on pruning, fertilizing, support systems, lighting protection, and safety.
- (2) Replacing Unhealthy Landscaping.** Unhealthy landscaping must be replaced with healthy, live plants by the end of the next applicable growing season. This includes all plant material that shows dead branches over a minimum of 25 percent of the normal branching pattern.
- (3) Maintenance Responsibility.** The owner is responsible for the maintenance, repair, and replacement of all landscaping.
- (4) Maintain Quality and Quantity.** Maintenance must preserve at least the same quantity, quality, and screening effectiveness as initially installed or required by this article.
- (5) City Inspection.** All landscaped areas regulated by this ordinance may be inspected by the city.

(6) Tree Maintenance. All trees required by this article must be maintained as follows:

- (a) Street Trees.** All tree maintenance in the city rights-of-way or dedicated parks must be performed under the direction of the licensed arborist or qualified landscape professional approved by the City.
- (b) Arborist.** Tree trimming, fertilization, and other similar work must be performed by or under the management of a certified arborist.
- (c) Tree Topping.** Tree topping is not allowed. When necessary, crown reduction thinning or pruning is permitted. Refer to 350-13.C for clear branch height of street trees.

660-67 Existing Significant Trees

660-67.A APPLICABILITY

The following development sites or parcels must meet the regulations of this section, 660-67:

- (1)** Development sites requiring a Master Plan Development (MPD) per 660-07.
- (2)** Sites abutting any named waterway.
- (3)** Sites over 1 acre and zoned IX, IG, or IM.

660-67.B SURVEY REQUIRED

A survey of existing significant trees on the site must be submitted as part of the zoning permit with documentation of the condition of the trees to be removed, prepared by a licensed arborist or qualified landscape professional. The burden of proof justifying the removal of a significant tree is on the applicant.

660-67.C MEASURING EXISTING TREES

Existing trees must be measured at the diameter of trunk, at breast height, 4.5 feet above grade at the base of the tree.

660-67.D SIGNIFICANT TREES

Trees of significant size, type, or meaning must be retained on the site, unless otherwise determined by the zoning officer per 660-67.D(3), below.

- (1) Definition.** A significant tree is one of the following:
 - (a)** Any tree with a diameter at breast height of 13 inches or more.
 - (b)** An historic tree, champion tree, or remembrance tree (defined in 597-5(6)(a)) based upon the tree’s age, species, health, meaning within the community, and/or historical importance.
- (2) Timing.** No tree may be removed for future construction without zoning approvals issued for the future development.

Table 660-7. Plant Material Size at Installation

PLANT MATERIAL TYPE	MINIMUM SIZE
Street Tree	2 in. caliper
Deciduous Shade/Overstory Tree	1.5 in. caliper/ 8 ft. height
Evergreen Tree	8 ft. height
Understory or Ornamental Tree	6 ft. height or 1.5 in. caliper
Shrubs - Deciduous	24 in. height
Shrubs - Evergreen	24 in. height
Groundcover	3 in. height

(3) Removal of Significant Trees. A significant tree may be removed with approval of the zoning officer under the following conditions:

- (a)** The tree is in poor health or diseased with an expected life span less than 2 years.
- (b)** The tree poses a danger to human safety, health, and welfare.
- (c)** Any required zoning approvals for new development on the site have been issued.
- (d)** If approved by the zoning officer, the removal is mitigated by one of the following:
 - [1] The planting of multiple trees, whose calipers at planting totaled equal the diameter of the removed tree(s), on the subject site.
 - [2] The planting of multiple trees, whose calipers at planting totaled equal the diameter of the removed tree(s) on a site approved by the zoning officer.
 - [3] The zoning officer determines that the tree must be removed for the environmental, economic, health, or safety of the city.

660-67.E PENALTIES

Any person who removes a significant tree without prior permission from the zoning officer or causes the death of a significant tree through other means as determined by the zoning officer must be subject to a fine. The fine must be paid into the city’s Tree Planting Fund in accordance with the city’s fee schedule. The fee must include a cost of 3 times per diameter inch of tree removed.

660-67.F TREES DAMAGED DURING CONSTRUCTION

Any significant tree that is damaged during construction must either be mitigated by replacement per 660-67.D(3) or a fee-in-lieu must be paid into the city’s Tree Planting Fund in accordance with the city’s fee schedule. The fee must include a cost per diameter inch of tree removed.

660-68 Ground Vegetation

660-68.A APPLICABILITY

All unpaved areas of any lot in any zone other than an N zone must be covered by either planting bed per 660-68.B or lawn per 660-68.C. See 660-74.D for parking lot areas to be landscaped.

660-68.B PLANTING BEDS

All planting beds may include shrubs, ornamental grasses, ground cover, vines, annuals, or perennials.

- (a)** A minimum of 60% of the bed area must be covered in plant material at maturity. The remaining portion of the bed may be covered with non-living permeable materials, such as mulch, pine straw, or gravel.
- (b)** Annual beds must be maintained seasonally, replanting as necessary.

660-68.C LAWN

Seeded, plugged, or sodded grasses, clover, or other alternative lawn or meadow plantings may be planted throughout landscaped areas.

- (1)** Lawn must be established within 90 days of planting or the area must be reseeded, replugged, or resodded.
- (2)** Meadow lawns must consist of grasses, naturally spreading groundcovers, and/or wildflowers native to the area.

660-69 Landscape for Large Street Yards

660-69.A APPLICABILITY

The regulations of this section, 660-69, apply to all buildings and sites in any P2, MX-S, IX, IG, or IM zone with an unpaved street yard deeper than 25 feet and 2,000 square feet.

660-69.B PLANTING BEDS

A minimum of 35% of the street yard must be planting beds, planted per 660-68.B.

660-69.C SITE TREES

For street yards larger than 4,000 square feet of unpaved area, a minimum of one large tree or 2 small trees must be planted for every full 4,000 square feet increment of unpaved area. For example, an unpaved street yard of 4,200 square feet requires either 1 large tree or 2 small trees, but an unpaved street yard of 10,000 square feet requires either 2 large trees, 4 small trees, or 1 large tree plus 2 small trees since it includes 2 increments of 4,000 square feet.

660-70 On-Site Walkways

660-70.A APPLICABILITY

The regulations of this section, 660-70.B, apply to all buildings and sites in all zones.

660-70.B ON-SITE WALKWAYS

- (1) Locations.** On-site sidewalks must continuously connect all public sidewalks to the main entrance of all principal buildings on the site.
 - (a)** One connection is required per street frontage, except in N zones where one connection is required only to the front street.
 - (b)** For all zones except N zones, connection to any abutting public trails and pathways is required.
 - (c)** Parking lots with more than two double-loaded aisles must have a dedicated sidewalk or pathway from the outer aisle to the principal entrance.
- (2) Width.** The width of any required on-site walkway in all zones except N zones must be a minimum of 5 feet.
- (3) Materials.** Walkways must be composed of concrete, brick, or other masonry pavers.
 - (a)** In any N zone, the material may be gravel, stepping stones, mulch, wood decking, or other approved materials.
 - (b)** Other materials may be approved by the zoning officer, provided the materials are appropriate for the level of pedestrian traffic expected on the site.
- (4) Vehicular Crossings.** Where on-site walkways cross driveways, parking areas, and loading areas, the following applies:
 - (a)** Walkway paving material must continue through the vehicular area and the crossing area must be clearly differentiated from the vehicular area.
 - (b)** If the material of the pedestrian and vehicular area is similar, the pedestrian area must be differentiated through the use of elevation changes, speed bumps, another paving material, scoring, or other similar method.
- (5) Accessible.** All sidewalks must comply with all local, state, and federal regulations for accessibility.

660-71 Street Trees

660-71.A INTENT

To line all streets with a consistent and appropriate planting of trees, establishing tree canopy for environmental and aesthetic benefits.

660-71.B APPLICABILITY

The regulations of this section, 660-71, apply to all buildings and sites in all zones.

660-71.C REQUIRED STREET TREES

Street trees must be installed on all lots, regardless of development type. See streetscape area regulations in 350-12 and the city's tree ordinance, Chapter 597 of the municipal code, for additional regulations.

660-72 Frontage Buffer

660-72.A INTENT

To lessen the visual impact of on-site vehicular parking, loading, and other activities primarily from the street.

660-72.B APPLICABILITY

The frontage buffer is required where lots contain 10 or more parking spaces along the edge of all surface parking lots, driveways, loading areas, and other vehicular areas abutting street rights-of-way, waterfront buffers, or open or civic spaces.

- (1) Outdoor Storage Uses, High Impact Industry Uses, and Outdoor Warehouse and Distribution Uses.** In lieu of the frontage buffer, the side and rear buffer B (660-73.F), must be installed surrounding outdoor storage areas (660-45), high-impact industry uses (660-32.D), and outdoor warehouse and distribution uses (660-32.G).

660-72.C REQUIREMENTS

Refer to Figure 660(22) for an illustration of these requirements.

- (1) Buffer Depth.** The required buffer area must be a minimum 5 feet in depth, measured from the street-facing lot line into the lot.
- (2) Buffer Location.** The required buffer area must extend along the full edge of the vehicular area frontage, but

may allow for the perpendicular crossing of driveways and walkways.

- (3) Optional Fences and Walls.** The following applies to any fence or wall included within the frontage area.
 - (a) Fence Location.** The fence should be located a minimum of 2 feet from the face of curb or edge of the vehicular area into the buffer.
 - (b) Height.** Fences and walls located in the frontage buffer may not exceed 4 feet in height, except that fences and walls with a solid to open area ratio of 1:1 or less (such as a picket, split rail or wrought iron fence) may be up to 6 feet in height (maximum).
 - (c) Wall Materials.** Walls must be constructed of brick or other masonry with a finished appearance.
 - (d) Additional Height.** Fences in frontage buffers in I zones may not exceed 10 feet in height. Walls in frontage buffers in I zones may not exceed 6 feet in height.
- (4) Buffer Landscape.** The following landscape is required within the buffer:
 - (a) Shade Trees.** Medium or large shade trees are required at a minimum of 40 feet on center, with at least one shade tree required for each segment of buffer. Where feasible, spacing of the buffer trees should alternate with street trees. Street trees may count as buffer trees provided the street trees are located to screen the areas and healthy.
 - (b) Hedge.** A single row of shrubs is required on the street-side of the buffer, consisting of shrubs with a minimum mature width of 24 inches each, spaced no more than 36 inches on center, and height maintained no more than 42 inches.
 - [1] For outdoor storage uses, the hedge must consist of a double row of shrubs.
 - [2] For vehicle sales uses, a single row of low shrubs is allowed.
 - (c) Existing Vegetation.** Existing vegetation may be credited toward buffer requirements per the zoning officer.

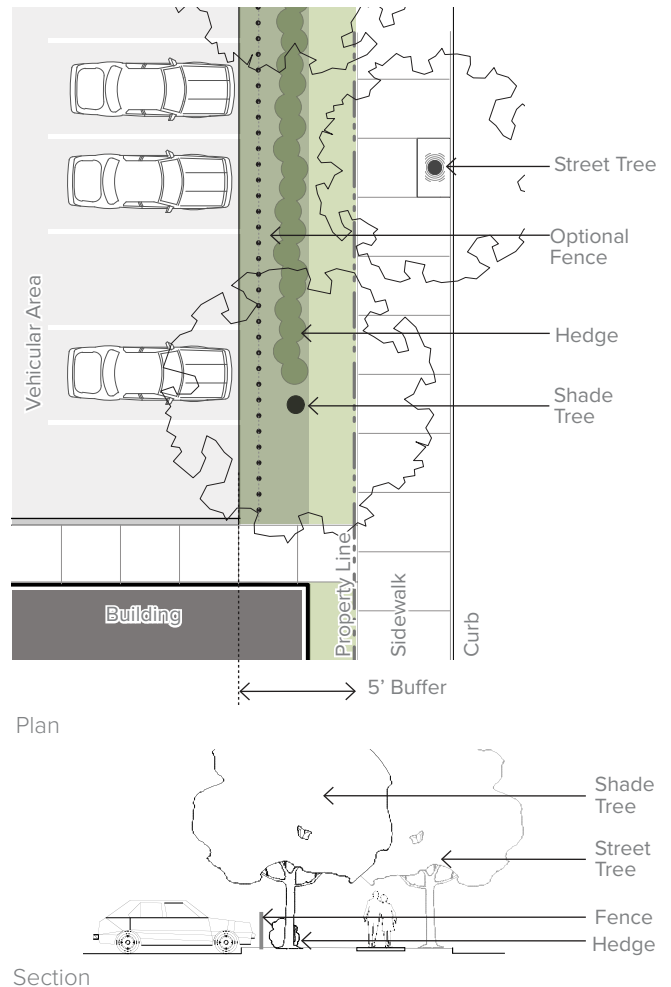

Figure 660(22) Frontage Buffer Plan & Section

660-73 Side and Rear Buffers

660-73.A INTENT

To minimize the impact that vehicular, outdoor storage, or loading activities have on abutting lots and to provide a transition between zones.

660-73.B APPLICABILITY

(1) Applicable Lots and Building Types. A side and rear buffer is required along the side and rear lot lines of all lots for all building types per this section, 660-73.

(a) House Building Type. Any House, Twin House, or Rowhouse building type used for residential principal use is exempt from any side and rear buffer.

(2) Existing Conditions.

(a) Existing Landscape. Existing mature, healthy landscape located within or abutting the buffer area, may be substituted for any buffer requirements, provided the existing landscape sufficiently buffers the activities as determined by the zoning officer.

(b) Existing Fence. Where an existing fence in good condition meets the buffer fence requirements, the following applies:

- [1] The existing fence may be used to fulfill the fence requirement in the buffer.
- [2] Should the existing fence be removed, a new fence must be provided.
- [3] New fences must not be placed parallel to an existing fence on an abutting lot in order to avoid a narrow alley between the fence of a distance less than 5 feet.

(c) Existing Topography. Where existing topography either reduces the need for or increases the visibility of the buffering or the use being buffered, the zoning officer shall determine the extent of needed buffering and may require additional landscape material as needed to buffer the uses.

660-73.C BUFFER LOCATIONS

(1) Activities Triggering Buffers. Side and rear buffers are required where the following occurs in the rear or side yards of a lot:

(a) Vehicular Areas. Any vehicular areas, abutting or adjacent to zones designated in Table 660-8. Vehicular areas include such areas as parking spaces, drives, drive-through uses, fueling stations, auto sales or rental lots, truck parking, and structured parking.

(b) Loading. Any loading areas abutting or adjacent to zones designated in Table 660-8. Loading areas

include such areas as loading bays, loading docks, service bays, garage doors, other outdoor trucking facilities.

(c) Service Areas. Any service areas abutting or adjacent to zones designated in Table 660-8. Service areas include such areas as delivery doors, refuse and recycling areas, outdoor employee break areas.

(d) Outdoor Storage Uses, High-Impact Industry Uses, and Outdoor Warehouse and Distribution Uses. The buffer B (660-73.F) must be installed on all lot edges surrounding outdoor storage areas (660-45), high-impact industry uses (660-32.D), and outdoor warehouse and distribution uses (660-32.G), unless otherwise determined by the zoning officer. Buffer must comply with any use regulations in Article 4 that may exceed these regulations.

(e) Other. Other outdoor activities emitting sounds, odors, or other by-products, such as outdoor dining, principal-use solar energy systems, or wind energy conversion systems, as determined by the zoning officer.

(f) Industrial Zones. In IG and IM locations, the following is required:

- [1] The buffer B is required along the side and rear yards of all IG- and IM-zoned lots abutting an N or NX zone regardless of vehicular activity, service, or outdoor storage areas.
- [2] The zoning officer may require buffers between buildings and adjacent lots in zones other than N or NX zones, if the use is determined to be of an intensity requiring buffering.

(2) Location on the Lot. Side and rear buffers must be installed along the lot line or the buffer may be located at the edge of the activity being buffered, provided the area between the buffer and the lot line is landscaped with ground vegetation per 660-68 and one tree per every 2,000 square feet.

(3) Access Points. Driveways and other access points may interrupt buffers as necessary.

660-73.D FENCE BUFFER

See Table 660-8 where required. See Figure 660(23) for illustration.

(1) Intent. The fence is intended to provide a physical and visual separation for uses of different intensities where limited buffer area is available.

(2) Buffer Depth. A minimum 2-foot width buffer, measured from the lot line onto the subject lot, is required.

- (3) Fence, Wall, or Hedge.** A continuous fence, wall, or shrub hedge is required on the inside perimeter of the buffer, consistent with one of the following:
- (a) Fence or Wall Option.** A minimum 6-foot, maximum 10-foot high, opaque, privacy fence or minimum 6-foot, maximum 8-foot wall screening the activity must be located in the buffer adjacent to the lot line. Allowed materials include PVC, composite wood, FSC wood (cedar, redwood, or other approved by the zoning officer), stone, or brick. Concrete panels and concrete masonry units are not allowed, except when faced on all sides with brick or stone.
 - (b) Shrub Hedge Option.** An evergreen hedge screening the activity must be located in the buffer adjacent to the lot line. The hedge must consist of a single row of evergreen shrubs, minimum 24 inches in width, spaced 24 inches on center, with a height at planting of 36 inches and a mature height of at least 6 feet. A solid visual screen must be created within 3 years.
- (4) Curbs or Wheel Stops.** A curb or wheel stops must be provided along the buffer edge at any vehicular area

to prevent motor vehicles from damaging the fence or hedge. Parking may not overhang into the buffer.

660-73.E BUFFER A

See [Table 660-8](#) where required. See [Figure 660\(24\)](#) for illustration.

- (1) Intent.** The buffer is intended to provide physical and visual separation for uses of different intensities.
- (2) Buffer Depth.** A minimum 5-foot width landscaped buffer, measured from the lot line onto the subject lot, is required.
- (3) Privacy Fence or Hedge.** See [660-73.D](#) for the requirements of the privacy fence or hedge.
- (4) Shade Trees.** Medium or large shade trees are required at a minimum of 40 feet on center, with at least one shade tree required for each segment of buffer.
- (5) Landscape.** The buffer area must be landscaped as planting bed. See [660-68](#) for required ground vegetation regulations.

Table 660-8. Side & Rear Buffer Required

		ABUTTING ZONES:									
		IG, IM	IX	MX-S	MX-D, GX-D	MX-C	GX-C	MX-N, GX-N	NX, N1, N2, N3, N4, N5	P1	P2
BUFFER REQUIRED ON LOTS ZONED:	IG, IM	-	Fence	Buffer A	Buffer A	Buffer A	Buffer A	Buffer B	Buffer B [1]	Buffer A	Buffer A
	IX	-	-	Fence	Buffer A	Buffer A	Buffer A	Buffer A	Buffer A	Buffer A	Buffer A
	MX-S	-	-	-	Buffer A	Buffer A	Buffer A	Buffer A	Buffer A	Buffer A	Buffer A
	MX-D, GX-D	-	-	-	-	-	Fence	Fence	Buffer A	Fence	Fence
	MX-C	-	-	-	-	-	Fence	Fence	Buffer A	Fence	Fence
	GX-C	-	-	-	-	-	-	Fence	Fence	Fence	Fence
	MX-N, GX-N, NX	-	-	-	-	-	-	-	Fence	Fence	Fence
	N1, N2, N3, N4, N5	-	-	-	-	-	-	-	-	-	-
	P1	-	-	-	-	-	-	-	-	-	-
	P2	-	-	-	-	-	-	-	-	Buffer A	Buffer A

See [660-73.C](#) for activities triggering buffer requirement.

[1] See [660-73.C\(1\)\(f\)](#). Buffer B required along all side and rear yards in IG and IM at N and NX zones.

660-73.F BUFFER B

See [Table 660-8](#) where required. See [Figure 660\(25\)](#) for illustration.

- (1) **Intent.** The buffer is intended to provide physical and visual separation for uses of different intensities.
- (2) **Buffer Depth.** A minimum 10-foot width landscaped buffer, measured from the lot line onto the subject lot, is required.
- (3) **Fence.**
 - (a) For outdoor storage uses and where expressly required in this ordinance, an 8-foot high security fence is required. This fence must be placed on the inside of the buffer.

(b) See [660-73.D](#) for the requirements of the privacy fence. The hedge option is not allowed.

- (4) **Shade Trees.** Medium or large shade trees are required at a minimum of 40 feet on center, with at least one shade tree required for each segment of buffer.
- (5) **Evergreen Trees.** Evergreen trees are required at a minimum of 20 feet on center, with at least one evergreen tree required for each segment of buffer. Evergreen trees must be at least 5 feet in height at planting, resulting in a complete year-round visual screen at least 8 feet in height within 4 years of planting.
- (6) **Landscape.** The buffer area must be landscaped as planting bed. See [660-68](#) for required ground vegetation regulations.

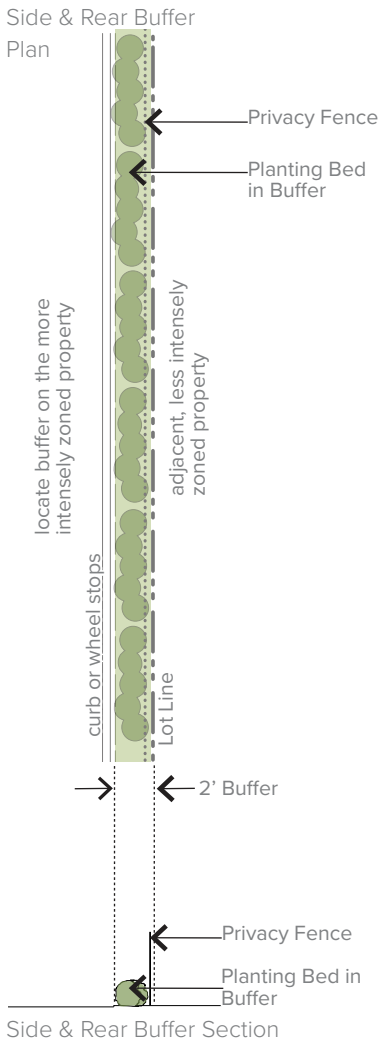

Figure 660(23) Fence

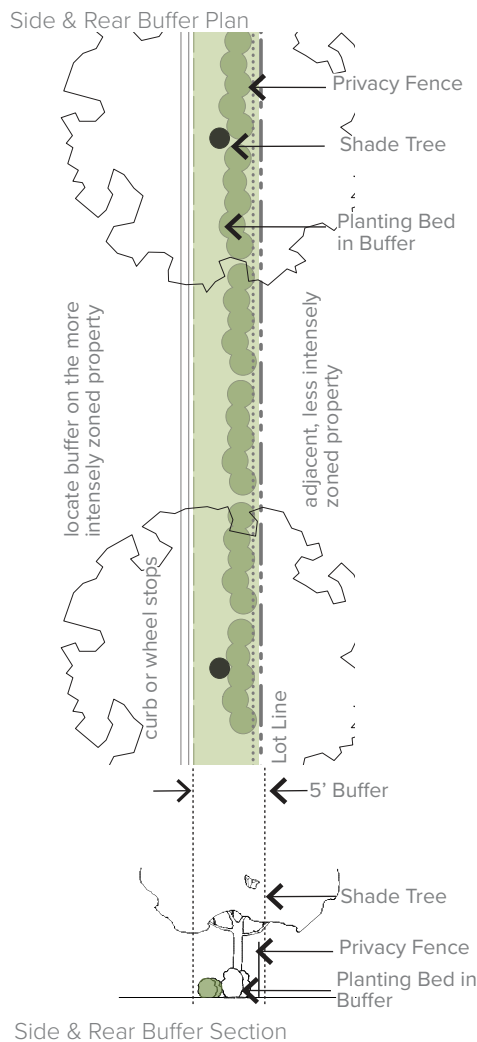

Figure 660(24) Buffer A

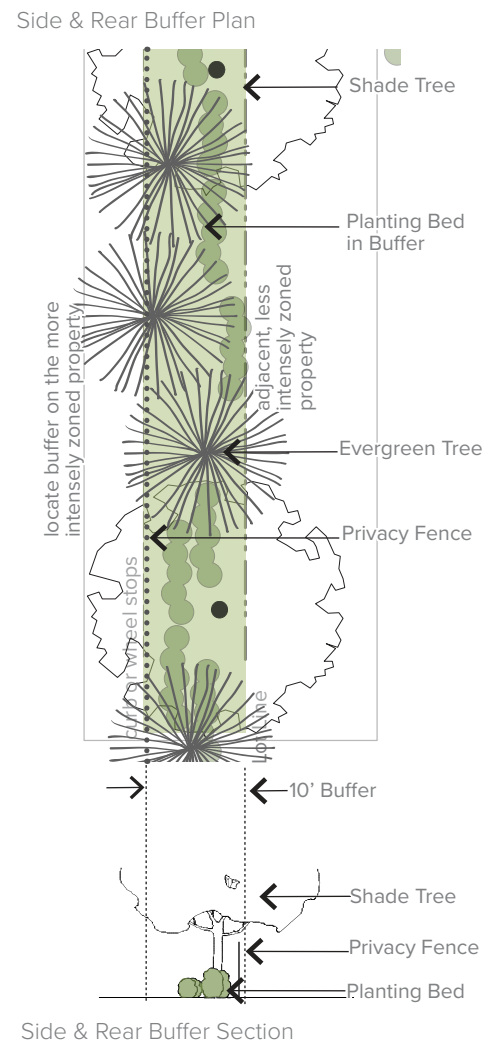

Figure 660(25) Buffer B

660-74 Interior Parking Lot Landscape

Parking lot interior is the area dedicated to parking on a given parcel as measured from edge of pavement to edge of pavement, and including any islands or medians. See [Figure 660\(26\)](#) for illustration of these requirements.

660-74.A INTENT

To provide shading of pavement surfaces to reduce heat island effects and to improve the appearance of parking lots by breaking up the large expanses of pavement with trees and landscaped islands.

660-74.B APPLICABILITY

All off-street surface parking lots in all zones with more than 10 spaces and/or more than one drive aisle must meet the interior parking lot regulations.

See [660-72](#) for frontage buffer along street frontages and [660-73](#) for side and rear buffers along the perimeter of the lot.

- (1) Existing vegetation may be credited toward these requirements per the zoning officer.
- (2) An alternative layout may be approved, provided the same percentage of landscape area and the same number of trees are included, and the design does not result in large expanses of paved areas of pavement without trees

660-74.C REQUIRED LANDSCAPE ISLANDS

- (1) **Terminal End Islands.** Landscape islands are required at the terminal ends of freestanding rows or bays of parking. Freestanding rows or bays of parking are those not abutting the parking lot perimeter or building face, and may have a single or double row of parking.

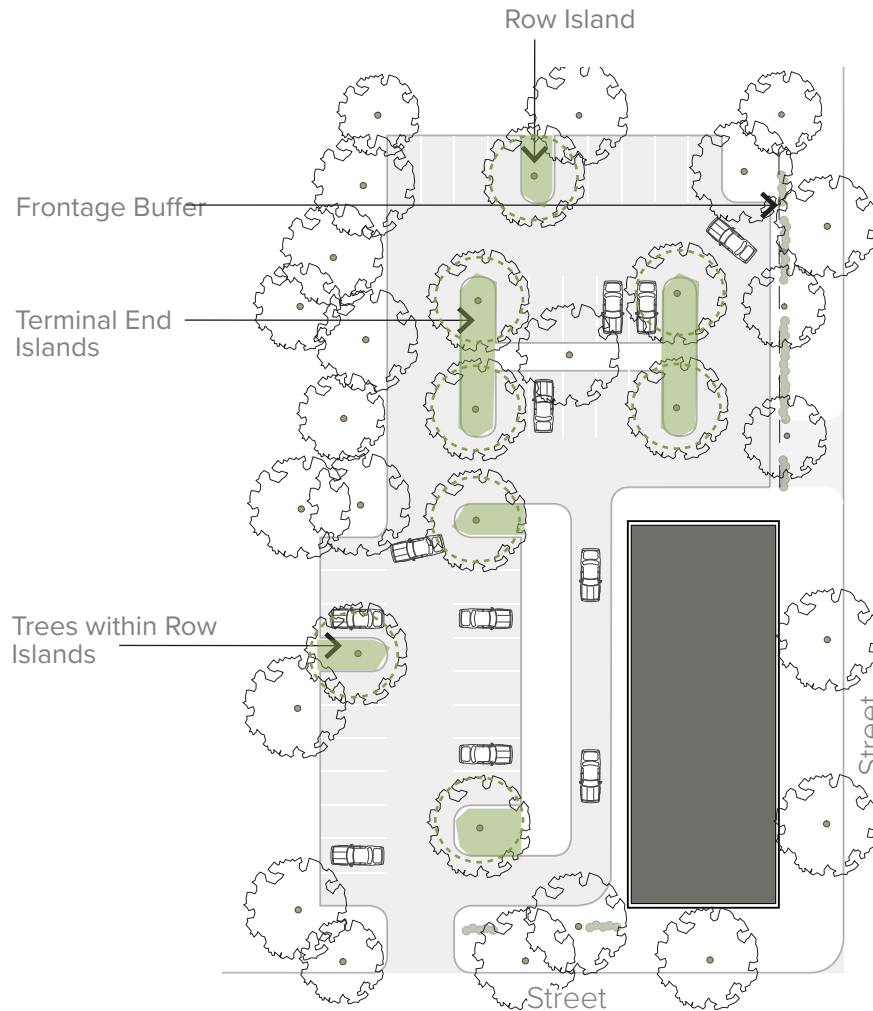

Figure 660(26) Interior Parking Lot Landscape

- (2) **Row Islands.** For rows of parking with more than 10 spaces, a landscape island is required for every 11th parking space with result of no more than 10 continuous parking spaces in a row without a landscape island.
- (3) **Island Size.** The minimum size of an island is 5 feet wide and the depth of a parking space. Refer to 660-65.D for required permeable surface area for trees and alternative installation methods to achieve good tree health and survival rates.
- (4) **Island Trees.** A minimum of 1 medium or large shade tree must be installed within each island.
- (5) **Stormwater.** Islands may accommodate stormwater detention or retention areas, rain gardens, or other infiltration systems.

660-74.D LANDSCAPE AREAS

Areas in the parking lot not specifically designed for use as drive aisles, parking spaces, loading, refuse, or sidewalks must be unpaved, landscape areas. See 660-68 for required ground vegetation.

660-75 Steep Slope Regulations

660-75.A PURPOSE

The steep slope regulations of this section are established for the following purposes:

- (1) To conserve and protect steeply sloped land from inappropriate development that requires excessive grading and extensive vegetation removal;
- (2) To avoid significantly increased stormwater flow rates and velocities;
- (3) To avoid increased use of steep roads and driveways that are dangerous to drive upon in snow and ice, and that are difficult for emergency vehicles to access;
- (4) To avoid potential hazards to property and the disruption of ecological balance that may be caused by increased surface water runoff, flooding, soil erosion and sedimentation, blasting and ripping of rock, and landslides;
- (5) To encourage the use of steeply sloped land for conservation and other uses that are compatible with the preservation of natural resources and protection of the environment; and
- (6) To avoid loss of biodiversity and wildlife habitat and corridors.

660-75.B APPLICABILITY

The regulations of this section apply when any construction, subdivision and/or earth disturbance activities on lots in excess of 6,000 square feet in area that contain slopes of 25% or greater. The regulations do not apply in any the following circumstances:

- (1) If the total area of slopes of 25% or greater is less than 500 square feet;
- (2) If the disturbance is for the purpose of widening, alignment, improvement, sight distance improvement or similar improvement of an existing street by the city or the Pennsylvania Department of Transportation;
- (3) If the slopes in excess of 25% were created by permitted grading or other construction or earthmoving activities permitted under applicable regulations; or
- (4) If the slopes were clearly human-made, such as areas that were graded previously for buildings, basins, quarrying, or other features. The burden of proof is on the applicant to show that slopes were human-made, such as by showing that grading occurred to develop a previous adjacent building; or
- (5) If the construction or earth disturbance is for the installation of public utilities that are not associated with any other activity regulated by this section.

660-75.C CALCULATION OF SLOPES

- (1) Slope is the relationship of vertical rise to horizontal run, expressed as a percentage from the toe to the top of the slope. For example, land that rises 25 feet over a horizontal distance of 100 feet has a slope of 25%.
- (2) Any area that contains slopes of 25% or more is considered steeply sloped for purposes of these regulations.
- (3) For any application involving a lot that appears to include areas of steep slopes, the applicant must, using 2-foot contours, delineate slopes of 25% to 35%; and greater than 35%. The applicant must conduct an actual field topographic survey as the source of contour information and the basis for depicting such slope categories or use other sources of slope information deemed acceptable by the city engineer.
- (4) All steeply sloped areas must be shown for the purpose of review and verification, but these regulations apply only to those steep slopes occurring over 3 consecutive 2-foot contour intervals (i.e., 6 cumulative vertical feet of slope).
- (5) Once delineated, the mapping provided by the applicant must be reviewed by the city engineer. Applicants are required to follow all regulations of this section for those areas that contain steeply sloped areas, as determined in accordance with this section through the city engineer's review.

660-75.D APPLICATION PROCEDURES

- (1) Before a permit is issued for any construction or land disturbance on land within or affecting steeply sloped areas, the applicant must submit plans drawn to a scale of at least one inch equals 50 feet, sealed by a registered professional engineer, Pennsylvania licensed land surveyor or Pennsylvania registered landscape architect (in the case of a subdivision or land development, required plans may be submitted as part of that application):
 - (a) The location, dimensions and elevation of the property.
 - (b) An earthmoving plan of the property identifying existing and proposed grades with contour lines at 2-foot intervals within the area of any proposed activity, disturbance or construction. All steeply sloped areas must be graphically highlighted using the gradients identified above.
 - (c) A site plan indicating existing and proposed buildings, structures, other impervious surfaces, storm drainage facilities and retaining walls. The site
- (2) Required plans must depict at least the following information:
 - (a) The location, dimensions and elevation of the property.
 - (b) An earthmoving plan of the property identifying existing and proposed grades with contour lines at 2-foot intervals within the area of any proposed activity, disturbance or construction. All steeply sloped areas must be graphically highlighted using the gradients identified above.
 - (c) A site plan indicating existing and proposed buildings, structures, other impervious surfaces, storm drainage facilities and retaining walls. The site

plan must also depict areas of existing vegetation, including woodlands (areas where healthy trees of over 6 inches in diameter (measured at a height of 4.5 feet above the average surrounding ground level), open areas and their ground cover type, as well as landscaping material proposed to be installed.

- (d) When required by the city engineer and/or planning commission, typical cross-sections and elevations of the property, and proposed buildings and structures at intervals prescribed by the city engineer, as well as architectural plans, building elevations, and site sections.
- (e) A chart detailing the calculation of the steep slope areas and the percentage of disturbance for each gradient identified.
- (f) A statement and/or plans, signed and sealed by a registered architect or professional engineer indicating:
 - [1] The building methods to be used in overcoming foundation and other structural issues created by slope alteration;
 - [2] The proposed techniques to preserve natural drainage and prevent soil erosion and sedimentation; and
 - [3] The methods proposed to avoid excessive surface water runoff to neighboring properties and/or streets.
- (g) Plan, profile and typical cross-sections of any proposed street, emergency access or driveway within areas of steep slopes, sealed by a registered professional engineer.

660-75.E STEEP SLOPE STANDARDS

The standards of this subsection apply whenever areas of steep slopes are proposed for development or disturbance.

- (1) In areas with slopes of 25% to 35%, no more than 25% of the total of such areas may be altered, regraded, cleared, built upon or otherwise altered.
- (2) Alteration, regrading, clearing, building, and similar activities are prohibited in areas with slopes of greater than 35%.
- (3) The planning commission may grant a waiver to the limitations set forth in paragraphs 1 and 2 above to permit the construction of a public street, driveway or other suitable access; public or private utility or other required facility when the planning commission determines that no other alternative exists for providing access to the remainder of the parcel or other required facilities. Such waivers must be limited to only the

minimum amount of disturbance required to install the necessary facility.

- (4) The proposed development, any impervious cover and resultant disturbance to the land and existing vegetative cover may not cause stormwater runoff and/or related environmental problems beyond the subject site.
- (5) Removal of or disturbance to existing vegetation in steep slope areas must be minimized. The proposed impacts on existing vegetation must be evaluated in terms of the potentially detrimental effects on slope stability, conveyance and recharge of stormwater, aesthetic characteristics of the landscape and existing drainage patterns. Further, it must be demonstrated that any and all reasonable mitigation techniques and procedures will be utilized or have been considered in the preparation of the plan, such as revegetation measures, control of soil erosion and sedimentation, stormwater management, and the like. For purposes of such demonstration, the city engineer may request additional information including, but not limited to, an erosion and sedimentation plan.
- (6) Important visual qualities of the site must be retained to the maximum extent possible. In addition to vegetation, these may include hilltops/ridgelines, rock outcroppings, and the natural terrain and contours of the site.
- (7) Road and driveway construction must follow the natural topography to the maximum extent possible. Cuts, fills and grading must be minimized. The design of new streets must comply with the street standards contained in the land development and subdivision ordinance, Chapter 350 of the municipal code. Driveways may not exceed a maximum slope of 15%. The initial 20 feet of a driveway from the connecting street cart may not exceed 6%.
- (8) Innovative, imaginative building techniques that are well-suited to slope conditions are encouraged, consistent with other applicable codes and regulations.
- (9) The stability of the slope, as characterized by the existing interrelationships among the soil, vegetation, and rock, must be disturbed as little as possible.
- (10) Proposed buildings and structures must be of sound engineering design. Footings must be designed in response to the site's slope, soil and bedrock characteristics. Footings must extend to stable soil and/or bedrock.
- (11) All disturbed areas must be stabilized and seeded or planted, and notes to this effect must appear on all plans.
- (12) Finished slopes of all permitted cut and fill may not exceed 3:1 or 33%, unless the applicant can demonstrate

the method by which steeper slopes can be stabilized and maintained adequately to the satisfaction of the city engineer and/or planning commission.

- (13) The maximum vertical drop from a terrace or retaining wall used to stabilize and control steep slopes may not exceed 5 feet.

660-76 Soil-Disturbing Activities

All soil disturbing activities must be performed in accordance with the provisions of the city's land development and subdivision ordinance, Chapter 350 of the municipal code. The deposit of soils, detritus or other debris that would be unsightly or detrimental to surrounding properties, streets, sewers and natural waterways as a result of site preparation, grading and/or excavating is prohibited.

660-77 Performance Standards

660-77.A APPLICABILITY

The operational performance standards of this section apply to all uses unless otherwise expressly stated in this zoning ordinance.

660-77.B ODORS, DUST AND POLLUTION

Uses must be operated so that they do not cause or result in continuous, frequent or repetitive noxious odors or dust that is detectable beyond the subject property. All uses must be operated in compliance with all applicable state and federal air and water pollution regulations.

660-77.C GLARE

All activities that cause glare (such as arc welding, acetylene torch cutting or similar processes) must be conducted within an enclosed building or be completely screened from view from any point beyond the property line.

660-77.D GASES

Uses must be operated so that they do not emit gases that are deleterious to public health or safety.

660-77.E ELECTRICAL DISTURBANCE

Uses must be operated so that they do not routinely cause electrical, radio or electromagnetic disturbances to electronic receiving equipment on another lot.

660-77.F NOISE AND VIBRATION

Uses must be operated in compliance with the noise and vibration standards established in [Chapter 400](#).

660-77.G FIRE AND SAFETY HAZARD

- (1) The storage of crude oil or any of its volatile products or other highly flammable liquids or gases in above-ground tanks must comply with all applicable city, state, and federal regulations.

- (2) The permitted manufacture or storage of explosive, toxic or hazardous materials must comply with all applicable city, state, and federal regulations.

660-77.H LIQUID WASTE

Liquid wastes and effluent must be discharged into the city of Allentown wastewater treatment plant in accordance with the regulations of that system or must be treated in a treatment plant operated by the permitted use that complies with all applicable state, federal, and city requirements.

660-77.I COMBUSTIBLE MATERIAL STORAGE

- (1) The bulk storage of lumber, coal or other combustible material must be setback at least 20 feet from all lot lines, and a paved driveway must be provided from a paved street into the property to permit access by fire protection and emergency vehicles.
- (2) The bulk commercial storage, baling, processing or treatment of rags, wastes, scrap paper or similar materials must take place in an enclosed building of fire-resistant construction, no part of which may be located within 50 of from any lot line.
- (3) See also:
 - (a) The screening regulations of 660-73;
 - (b) The industrial and infrastructure site regulations of 660-13.C;
 - (c) The outdoor storage regulations of 660-45; and
 - (d) Storage-related high-impact industry supplemental use regulations of 660-32.D.

660-77.J LIGHT AND GLARE

- (1) **Street Lighting Exempted.** The regulations of this subsection do not apply to street lighting that is owned, financed or maintained by the city, state or public utility.
- (2) **Diffused.** All light sources, including signs, must be properly diffused with a translucent or similar cover to prevent the lighting element from being directly visible from streets, public sidewalks, dwellings or adjacent lots. Five or more bare incandescent light bulbs of 40 watts or greater may not be hung along a public street or an abutting property.
- (3) **Shielding.** All light sources, including signs, must be shielded around the light source and directed and placed to prevent the lighting from creating a nuisance to persons in adjacent dwellings or undeveloped residentially zoned areas, and to prevent glare into the eyes of passing motorists.
- (4) **Flickering.** Flashing, flickering or strobe lighting are prohibited, except for seasonal holiday lights between October 25th and January 10th.

660-77.K NUISANCES & PUBLIC SAFETY

Uses and activities that seriously threaten or cause a significant hazard to public health and safety because of serious explosive, fire, biological, biogenetic or toxic hazards are prohibited. See also the city fire prevention code.

660-77.L AIR NAVIGATION

Uses and activities that disrupt or interfere with radar or other airport navigational or safety equipment are prohibited.

660-77.M WETLANDS

If the zoning officer or the city engineer has reason to believe that a portion of a site proposed to be altered or drained may possibly qualify as state or federal protected wetlands, the zoning officer may require the applicant to provide a study by a qualified professional delineating the locations of such wetlands. However, the city accepts no responsibility to identify all wetlands or to warn parties of such possibilities.

[page intentionally blank]

ARTICLE 8. PARKING, MOBILITY, & ACCESS

660-78 General 8-2
660-79 Motor Vehicle Parking Ratios 8-2
660-80 Calculations 8-4
660-81 Parking Exemptions, Reductions, and Credits 8-4
660-82 Shared Parking 8-6
660-83 Alternative Compliance 8-6
660-84 Bicycle Parking 8-6
660-85 Location of Off-Street Parking 8-7
660-86 Parking Areas Layout and Design 8-8
660-87 Vehicle Stacking 8-9
660-88 Loading 8-10

660-78 General

660-78.A PURPOSE

- (1) The provisions of this article are intended to balance the city's goals of:
 - (a) Promoting walking, bicycling, and transit use; and
 - (b) Providing reasonable amounts of off-street parking for shoppers, visitors, and residents.
 - (c) Reducing on-street parking demands on nearby residential streets.
- (2) The parking requirements of this article are designed to respond to the general day-to-day needs of businesses, shoppers, employees, residents, and visitors while also avoiding the negative impacts that can result from requiring excessive quantities of off-street parking.
- (3) The provisions of this article are also intended to help protect the public health, safety and general welfare by:
 - (a) Promoting economically productive use of land; and
 - (b) Providing flexible methods of responding to the transportation and access demands of various land uses in different areas of the city.

660-78.B APPLICABILITY

- (1) **General.** Off-street parking and loading must be provided and maintained in accordance with the provisions of this article. Unless otherwise expressly stated, the regulations apply to all zones and uses.
- (2) **New Uses and Development.** The parking regulations of this article apply to all new buildings constructed and all new uses established in all zones.
- (3) **Change of Use.** If a newly established use on a lot requires more off-street parking than the use that most recently existed on that lot, additional off-street parking is required in an amount equal to the difference between the parking required for the new use and the parking that would have been required for the previous use if the parking requirements of this article had been applicable to the previous use. There is no requirement to address parking deficits associated with existing, lawfully established uses.
- (4) **Enlargements and Expansions**
 - (a) The parking regulations of this article apply whenever an existing building or use is enlarged or expanded to include additional dwelling units, floor area, or other units of measurement used in establishing off-street parking requirements.
 - (b) In the case of enlargements or expansions that trigger requirements for additional parking, additional spaces are required only to serve the

enlarged or expanded area, not the entire building or use. There is no requirement to address parking deficits associated with existing, lawfully established buildings or uses.

(5) Damage or Destruction

- (a) When a use that has been damaged or destroyed is re-established, off-street parking or loading facilities must also be re-established or continued in operation in an amount equal to the number maintained at the time of such damage or destruction. It is not necessary, however, to restore or maintain parking facilities in excess of those required by this zoning ordinance.
- (b) If a use that has been damaged or destroyed is not re-established within one year, the use's nonconforming parking rights are lost and such use may be re-established only in compliance with the off-street parking regulations of this article.

(6) Maintenance. Required off-street parking spaces must be maintained for the life of the principal use.

660-78.C USE OF OFF-STREET PARKING AREAS

- (1) Required off-street parking spaces are intended to serve residents, tenants, patrons, employees, and guests of the principal use. Required off-street parking areas may be used solely for the temporary parking of licensed motor vehicles in operating condition.
- (2) Required off-street parking spaces may not be used for the storage, display or sale of goods equipment or materials, except that the zoning officer is authorized to approve temporary use of off-street parking areas for display and sales of holiday and seasonal items (e.g., Spring gardening supplies and Christmas trees).
- (3) No motor vehicle repair work of any kind is permitted in a required parking space. This provision is not intended to prohibit residents of the subject property from servicing vehicles they own. The zoning officer is authorized to require proof of vehicle ownership.
- (4) Required parking spaces may be used for electric vehicle charging.

660-79 Motor Vehicle Parking Ratios

660-79.A PARKING TABLE

Off-street motor vehicle parking spaces must be provided in accordance with the minimum and maximum ratios established in Table 660-9 unless otherwise expressly stated. See 660-81 for provisions governing off-street parking exemptions, reductions, and credits.

Table 660-9. Parking Ratios **MINIMUM NUMBER OF MOTOR VEHICLE PARKING SPACES REQUIRED**

USE	MX-D AND GX-D ZONES	ALL OTHER ZONES	NOTES
RESIDENTIAL			
Household Living, 1 unit	No minimum	N1 and N2 zones: 1 per dwelling unit All other zones: 2 per dwelling unit	
Household Living, 2–4 units	No minimum	N1 and N2 zones: 1 per dwelling unit All other zones: 1.5 per dwelling unit	
Household Living, 5+ units	0.75 per dwelling unit	1 per dwelling unit	
Student Residence	NA	2 per dwelling unit	
Group Home	See 660-30.C(4)(g)	See 660-30.C(4)(g)	
Congregate Living	1 per 4 beds	1 per 4 beds	plus 1 per 2 employees
COMMERCIAL			
Adult Use	No minimum; Maximum number may not exceed 125% of the minimum requirement that applies in all other zones	1 per 100 sf	
Animal Service		Indoor: 1 per 400 sf All other: 1 per 15 animals	
Child Care Center		1 per 12 enrollees	
Child Care, Group		1 per nonresident employee	
Consumer Service, Indoor		1 per 400 sf	
Day Care Center, Adult		1 per 12 enrollees	
Eating and Drinking Places		1 per 5 seats	1 per 400 sf if no fixed seating or when located in multi-tenant center
Entertainment, Spectator/Participant		1 per 5 seats	1 per 400 sf if no fixed seating
Funeral & Mortuary Service		1 per 50 sf	
Lodging		1 per 2 guest rooms	plus spaces required for other on-site uses
Office		1 per 400 sf	
Retail Sales		1 per 400 sf	
Self-Service Storage, Indoor		Established per 660-80.H	
Vehicle Sales & Service		1 per 400 sf sales area	plus 2 per service bay and 1 per 2 employees
MANUFACTURING & INDUSTRY			
50,000 square feet of less	No minimum	1 per 4 employees	
More than 50,00 square feet	No minimum	1 per 2 employees	
CIVIC & INSTITUTIONAL			
Cemetery	No minimum	No minimum	
College or University		1 per 3 off-campus, full-time students	plus 1 per 2 employees; plus spaces required for dormitory or other residential use
Community Assembly		1 per 4 seats	1 per 400 sf if no fixed seating
Detention or Correctional Facility		1 per 2 employees	
Hospital		1 per 4 beds	plus 1 per 2 employees
Library or Cultural Exhibit		1 per 400 sf	
Parks and Open Space		Established per 660-80.H	
Safety Service		1 per 2 employees	
School		1 per 6 students in 11th–12th grades	plus 1 per 2 employees
Infrastructure & Utilities, Minor		No minimum	
Infrastructure & Utilities, Major		1 per 2 employees	1 space minimum

sf = square feet of floor area (see 660-80.C)

660-80 Calculations

660-80.A MULTIPLE USES

Lots containing more than one use or tenant must provide parking in an amount equal to the total aggregate number of spaces required for each use or tenant on the lot except when a shared parking arrangement is approved in accordance with 660-82.

660-80.B ROUNDING

When calculating off-street parking requirements, any fractional result of less than one-half is rounded down to the next lower whole number and any fractional result of one-half or more is rounded up to the next higher whole number.

660-80.C FLOOR AREA (SQUARE FEET)

For purposes of calculating off-street parking requirements based on floor area (sf), the sum of the gross horizontal areas of the several floors of the building or portion of building devoted to such use, measured to the centers of all partitions, are counted. However, the following are not counted:

- (1) Areas devoted primarily to dead storage, building maintenance, or utilities;
- (2) Restrooms and dressing rooms;
- (3) Window showcases;
- (4) Employee meal areas and conference rooms;
- (5) Area devoted to off-street parking or loading facilities, including aisles, ramps, and maneuvering space; and
- (6) Basement floor area other than area devoted to retailing activities, to the production or processing of goods, or to business or professional offices.

660-80.D BENCH SEATING

In stadiums, sport arena, religious institutions, and other places of assembly in which patrons or spectators occupy benches, pews, or other similar seating facilities, each 30 inches of such seating are counted as one seat.

660-80.E EMPLOYEES OR STUDENTS

For the purpose of computing parking requirements based on employees or students, calculations must be based on the average number of persons working on the largest shift or the average enrollment, whichever is applicable.

660-80.F OUTDOOR SEATING

Unenclosed outdoor seating areas containing 20 or fewer seats are not counted when calculating off-street parking requirements for restaurants. All unenclosed outdoor seating areas with capacity for 20 or more seats are counted.

660-80.G UNLISTED USES

Upon receiving a permit or development application, the zoning officer is authorized to apply the off-street parking ratio specified for the listed use that is deemed most similar to the proposed use or establish an off-street parking requirement for the proposed use in accordance with 660-80.H.

660-80.H ESTABLISHMENT OF PARKING RATIOS

The zoning hearing board is authorized to establish required minimum parking ratios for unlisted uses and in those instances where authority to establish a requirement is expressly granted. Such ratios must be established on the basis of (1) a similar use determination, as described in 660-29.D; (2) parking data provided by the applicant; or (3) other information available to the zoning hearing board. Parking data and studies must include estimates of parking demand based on reliable data collected from comparable local uses or on external data from credible research organizations, such as the Urban Land Institute (ULI) and the Institute of Transportation Engineers (ITE). Comparability will be determined by density, scale, bulk, area, type of activity and location. Parking studies must document the source of all data used to develop recommended requirements.

660-80.I REDUCTIONS AND CREDITS

The methodology for calculating allowed parking reductions and credits is established in 660-80.C.

660-81 Parking Exemptions, Reductions, and Credits

660-81.A APPLICABILITY

The off-street parking exemptions, reductions, and credits allowed in this section may not be used to reduce off-street parking requirements for accessory dwelling units, as established in 660-38.B.

660-81.B PARKING EXEMPTIONS

- (1) **Small Nonresidential Uses**
 - (a) Off-street parking is not required for nonresidential uses on lots with an area of 2,000 square feet or less.
 - (b) Off-street parking is not required for nonresidential uses occupying floor area of 2,000 square feet or less if the lot occupied by such use is in an MX-C zone abutting North 7th Street.
- (2) **Lane Rowhouses.** Off-street parking is not required for Lane Rowhouses.
- (3) **Urban and Town Rowhouses.** Off-street parking is not required for principal dwelling units in Urban Rowhouse and Town Rowhouse buildings when all of the following criteria are met:

- (a) Applicable zoning regulations prohibit front or street yard parking on the subject lot;
- (b) Driveway access restrictions or other constraints prohibit access to off-street parking spaces in allowed locations; and
- (c) The constraints or other circumstances affecting the provision of otherwise required off-street parking spaces are not the result of the actions of the property owner (i.e., not self-created).

660-81.C PARKING REDUCTIONS AND CREDITS

(1) General

- (a) The parking reductions and parking credits allowed by this section may be applied singularly or in combination, provided that the total reduction in required parking does not exceed 50% of the minimum requirements stated in Table 660-9.
- (b) When applying parking reductions and parking credits, parking reductions must be applied before parking credits.
- (c) When applying multiple parking reductions, such reductions must be applied in descending order of reduction, with the greatest percentage reduction applied first (e.g., 25%, 15%, etc.). If reductions are of equal value, the reductions are applied sequentially (e.g., 25%, 25%). In all cases, the first reduction is applied to the minimum parking requirement stated in Table 660-9, with each additional reduction applied to the newly calculated amount of required parking. Mathematical rounding allowed by 660-80.B is applied to the final parking amount calculated through parking reductions.
- (d) For example, Table 660-9 requires that a 100-unit apartment building in an MX-D zone provide a minimum of 75 parking spaces (0.75 spots per dwelling unit). If such building was eligible to take parking reductions for providing affordable housing (25% reduction) and for its location in a high-capacity transit-served location (25% reduction), required parking would be calculated as follows:
 - [1] First, calculate the initial 25% reduction: (75 spaces minus (75 x 0.25)) = 56.25 spaces;
 - [2] Second, calculate and apply the second 25% reduction (56.25 minus (56.25 x 0.25)) = 42.19 spaces, which is rounded to 42 spaces or a reduction of 44%.
 - [3] Third, apply any available parking credits until the not-to-exceed reduction threshold of 50% is met, in this example, up to 4 additional parking

spaces may be removed before reaching the maximum 50% parking reduction.

(2) Parking Reductions

- (a) **Affordable Housing.** Off-street parking requirements are reduced by 25% for all dwelling units in a building occupied by affordable housing units meeting the eligibility criteria of 660-30.A(3)(c).
- (b) **High-Capacity Transit-Served Locations (High-Capacity Transit).** Off-street parking requirements are reduced by 25% for uses located on lots within 800 feet of a high-capacity transit bus stop.

(3) Parking Credits

- (a) **Public Parking.** Nonresidential uses are credited for parking spaces within a nearby public parking lot or public parking garage, as follows:
 - [1] Minimum parking requirements for the subject use are reduced by one parking space for every 4 parking spaces within the public parking lot or garage;
 - [2] The nearest pedestrian entrance to the public parking lot or garage must be located within 800 feet of the lot on which the subject use is located; and
 - [3] The parking facility must be open to the general public from at least 6:00 a.m. to 10 p.m.
- (b) **Car-Share and Bike-share Service.** Car-share and bike-share parking credits apply to nonresidential uses that are required to provide 15 or more motor vehicle parking spaces and to residential projects that are required to provide 25 or more motor vehicle parking spaces, as follows:
 - [1] The number of required motor vehicle parking spaces is reduced by 4 spaces for each parking space that is leased by a city-approved car-share program for use by a car-share vehicle.
 - [2] The number of required motor vehicle parking spaces is reduced by 2 spaces for uses that provide space for a city-approved bike-share program facility with a minimum of 8 bicycle parking docks.
- (c) **Electric Vehicle Charging.** In parking lots containing more than 15 parking spaces, each parking space equipped with Level 2 or Level 3 (DC) electric vehicle charging equipment is credited as 2 motor vehicle parking spaces for purposes of satisfying the minimum off-street parking ratios of Table 660-9. To receive credit, each electric vehicle charging station-equipped parking space must be publicly accessible and be identified by signs.

(d) Motorcycle and Scooter Parking. In parking lots containing more than 15 parking spaces, the provision of motorcycle or scooter parking spaces may be credited toward satisfying the minimum off-street parking ratios of Table 660-9 at the rate of one motor vehicle parking space for each 2 motorcycle or scooter parking spaces. To receive credit, each motorcycle and scooter space must have a concrete surface and minimum dimensions of 4 feet by 8 feet. Areas restricted to motorcycle and scooter parking must be identified by signs.

660-82 Shared Parking

660-82.A GENERAL

Shared parking refers to the practice of 2 or more users who need parking at different times making use of the same motor vehicle parking spaces. Shared parking is encouraged as a means of conserving scarce land resources, reducing stormwater runoff, reducing the heat island effect caused by large paved areas, and improving community appearance.

660-82.B ELIGIBILITY

The zoning hearing board is authorized to approve shared parking arrangements for nonresidential uses that have different periods of parking demand in accordance with the special exception procedures of 660-110. Required residential parking spaces and accessible parking spaces (for people with disabilities) may not be shared.

660-82.C SUBMITTAL REQUIREMENTS AND METHODOLOGY

Applicants proposing to use shared parking as a means of reducing overall motor vehicle parking requirements must submit the following with the special exception application:

- (1)** The names and addresses of the uses and of the owners or tenants that are sharing the parking;
- (2)** The location and number of parking spaces that are being shared;
- (3)** A shared parking study conducted in accordance with accepted methodology approved by the city, prepared by an independent traffic engineering professional under the supervision of the city and paid for by the applicant, demonstrating that the hours, size, and mode of operation of the respective uses does not create a substantial conflict in the peak parking demands of the uses for which shared parking facilities is proposed, and there is adequate parking to meet the parking needs for each use; and
- (4)** A properly drawn legal instrument, which must be filed as a deed restriction on all impacted properties, guaranteeing access to the parking for the shared parking users. The agreement is subject to approval by

the city and must be recorded with the county recorder of deeds.

660-83 Alternative Compliance

The minimum motor vehicle and bicycle parking requirements of this article are not intended to be a barrier to development or redevelopment or to make development and redevelopment economically impractical or negatively impact the viability of businesses. In order to allow for flexibility in addressing the actual expected parking demand of specific uses, modifications of the minimum and maximum off-street parking requirements of this article may be approved through the special exception procedures of 660-110 only if:

- (1)** The applicant submits a parking study demonstrating that the parking ratios of Table 660-9 or Table 660-10 do not accurately reflect the actual day-to-day parking demand that can reasonably be anticipated for the proposed use based on field surveys of observed parking demand for similar use within the city or on external data from credible research organizations, such as the Urban Land Institute (ULI) or the Institute of Transportation Engineers (ITE);
- (2)** The zoning hearing board determines that the other exemption, reduction, and credit provisions of this article are infeasible or do not apply; and
- (3)** The zoning hearing board determines that the proposed alternative parking ratios are consistent with the general purposes of 660-78.A and are not likely to cause material adverse impacts on traffic circulation and safety or on the general welfare of property owners and residents in the surrounding area.

660-84 Bicycle Parking

660-84.A PURPOSES

- (1) Short-term Bicycle Parking.** Short-term bicycle parking is generally intended to serve the needs of cyclists who park their bicycles for fewer than 3-hour time periods, including customers, clients, messengers, and other short-term visitors.
- (2) Long-term Bicycle Parking.** Long-term bicycle parking is generally intended to serve the needs of cyclists who park their bicycles for more than 3-hour periods, including employees, residents, students, and commuters.

660-84.B SPACES REQUIRED

Short-term and long-term bicycle parking spaces must be provided in accordance with the minimum bicycle parking ratios of Table 660-10.

Table 660-10. Bicycle Parking

USE/BUILDING TYPE	BICYCLE PARKING SPACES (MIN)
RESIDENTIAL USES	
0–4 Dwelling Units	None
5+ Dwelling Units	1 per 5 dwelling units [1]
COMMERCIAL USES	
All Commercial Uses	1 per 5,000 sf [2]
MANUFACTURING & INDUSTRY	
All Manufacturing & Industry Uses (based on employees)	0–5: None 6–20: 2 spaces [2] Over 20: 1 per 10 employees [2]
CIVIC & INSTITUTIONAL	
College or School	1 per classroom
Community Assembly	1 per 5,000 sf [2]
Library or Cultural Exhibit	1 per 5,000 sf

Table Notes:

sf = square feet of floor area (see also 660-80.C)

[1] At least 50% must be long-term bicycle parking spaces.

[2] At least 25% must be long-term bicycle parking spaces.

660-84.C LOCATION AND DESIGN

- (1) General.** All required bicycle parking spaces must:
- (a) Consist of bike racks or lockers that are anchored so that they cannot be easily removed;
 - (b) Be of solid construction, resistant to rust, corrosion, hammers, and saws;
 - (c) Allow both the bicycle frame and at least one wheel to be locked with the bicycle in an upright position using a standard U-lock;
 - (d) Be designed and installed so as not to cause damage to the frame, wheels, or components;
 - (e) Be accessible without interference from or moving adjacent bicycles and not result in a parked bicycle obstructing a required walkway; and
 - (f) Have minimum dimensions of 2 feet in width by 6 feet in length, with a minimum overhead vertical clearance of 7 feet.
- (2) Short-Term Bicycle Parking Spaces.** Short-term bicycle parking spaces must be at least as conveniently located as the most convenient non-disabled motor vehicle parking provided for the subject use. If no motor vehicle parking is provided, short-term bicycle parking spaces must be located within 50 feet of a building entrance. Short-term bicycle parking must be located on the subject lot, unless the city approves a proposal

to allow private bicycle parking facilities to be located in the right-of-way. Public bicycle parking spaces may be credited toward meeting short-term bicycle parking requirements if such bicycle parking spaces comply with the location requirements of this paragraph.

(3) Long-Term Bicycle Parking and Storage Spaces. Long-term bicycle parking spaces must:

- (a) Be located with direct access by the bicycle rider, with no more than 50% of the required spaces requiring the use of stairs or elevators;
- (b) May not be located in dwelling units or on dwelling unit balconies;
- (c) Must protect the entire bicycle, its components and accessories against theft and inclement weather, including wind-driven rain and snow.
- (d) Must be designed to allow bicycles to be securely locked to a bicycle rack in:

[1] A bike storage room that is accessible only to authorized users and has at least 2 electrical outlets;

[2] A bicycle locker with a separate access door for each bike; or

[3] An attended bike storage room.

660-85 Location of Off-Street Parking

660-85.A GENERAL

Except as otherwise expressly stated in this article, required off-street parking areas must be located on the same lot as the building or use they are required to serve or on an abutting lot under the same ownership. For purposes of this provision, lots separated only by a C street are considered to abut.

660-85.B OFF-SITE PARKING

- (1) When Allowed.** All or a portion of required off-street parking for residential uses in MX-D and GX-D zones and for nonresidential uses in all zones may be provided off-site, in accordance with the regulations of this section. Required accessible parking spaces and required parking for residential uses outside of MX-D and GX-D zones may not be located off-site.
- (2) Location.** Allowed off-site parking areas must be located within 800 feet of the use served by such parking, measured between the nearest public entrance door of the use to be served and the outer perimeter of the furthest parking space within the off-site parking lot. Off-site parking lots are allowed only in zones that permit off-street parking as a principal use or that allow the use to be served by the off-site parking (see Table 660-5).

- (3) **Design.** Off-site parking areas must comply with all applicable parking area design regulations of 660-86.
- (4) **Control of Off-Site Parking Area.** The property to be occupied by the off-site parking facilities must be under the same ownership as the lot containing the use to be served by the parking. The off-site parking area may be under separate ownership only if a legal instrument is provided guaranteeing the long-term availability of the off-site parking. The long-term lease or agreement is subject to approval by the city and must be recorded with the county recorder's office. Any proposed changes to the agreement must also be submitted to the city for review and approval.

660-85.C TRUCK PARKING IN N ZONES

Tractor-trailer trucks, trailers of a tractor-trailer combination, truck with a Class 5 license or above, or trucks with an aggregate gross vehicle weight of more than 11,000 pounds may not be parked for more than 2 hours per day on a lot in an N zone, except for:

- (1) Routine parking allowed as part of a lawful nonconforming nonresidential use, and
- (2) Temporary parking for on-site construction or repair activities.

660-86 Parking Areas Layout and Design

660-86.A APPLICABILITY

The parking layout and design regulations of this section apply to all off-street parking lots for motor vehicles, whether containing required or non-required parking spaces.

660-86.B INGRESS AND EGRESS

All parking areas and driveways must be designed to allow vehicles to enter and exit a street and cross public sidewalks in a forward motion, except that this requirement does not apply to lots occupied by house building types when motor vehicle access is to a "local street," as that term is defined in the city's Land Development and Subdivision Ordinance (Chapter 350).

660-86.C DRIVEWAYS

- (1) All driveways must be a minimum of 10 feet in width except as otherwise expressly stated in this zoning ordinance.
- (2) Residential driveways may not exceed 20 feet in width. All other driveways are limited to a maximum width of 22 feet, except as required to accommodate necessary truck turning radii.
- (3) Ribbon driveways may be used to provide individual access to single-household detached houses provided that:

- (a) The ribbons are located only on the driveway;
 - (b) The driveway apron is paved across its entire width;
 - (c) The ribbons are at least 2 feet in width and no more than 3 feet in width; and
 - (d) The ribbons are at least 3 feet apart measured from their nearest edges
- (4) Driveways must be designed to provide a stopping space not exceeding a 6% grade 20 feet behind the right-of-way line.

660-86.D PARKING STALL SIZE

- (1) **Standard Spaces.** Except as expressly allowed for compact spaces or as expressly required for accessible parking spaces, parking spaces must be at least 8.5 feet in width and at least 18 feet in length. Up to 2 feet of the front of a standard parking space, as measured from a line parallel to the direction of the bumper of a vehicle using the space, may be pervious landscape area instead of paved. Such areas count toward any applicable interior parking lot landscape requirements.
- (2) **Compact Spaces.** Up to 20% of required parking spaces may be designated, designed, and marked as compact parking spaces in multi-level parking structures, employee parking lots containing more than 50 spaces and parking areas served by an on-site attendant. Such compact spaces must be at least 8 feet in width and at least 16 feet in length.

660-86.E AISLE WIDTHS

- (1) Drive-aisle within off-street parking areas must be designed in accordance with Table 660-11, which shows minimum required aisle widths for various parking layouts (angles).

Table 660-11. Aisle Widths

STALL ANGLE	MINIMUM AISLE WIDTH (FEET)
0° (parallel) to 25°	12.0 (20 feet for two-way traffic)
25°–47°	13.0 (one-way)
48°–52°	14.0 (one-way)
53°–58°	15.0 (one-way)
59°–62°	16.0 (one-way)
53°–68°	17.0 (one-way)
69°–72°	18.0 (one-way)
73° or more	20.0 (one-way) 24.0 (two-way)

Note: Minimum aisle widths for parking stall angles of 45 degrees or greater may be reduced by 2 feet if minimum parking stall width is at least 9.5 feet.

660-86.F VERTICAL CLEARANCE

All required parking spaces must have overhead vertical clearance of at least 7 feet.

660-86.G SURFACING

All off-street parking areas and access drives must have dustless, durable, all-weather surface. Pervious pavement or a pervious pavement system designed to manage stormwater, only as part of a plan designed by a registered professional and approved by the city engineer, are allowable. Examples of pervious pavement or a pervious pavement systems include pervious asphalt, pervious concrete, modular pavers designed to funnel water between blocks, lattice or honeycomb shaped concrete grids with turf grass or gravel filled voids to funnel water, plastic geocells with turf grass or gravel, reinforce turf grass or gravel with overlaid or embedded meshes, resin bound pervious pavement systems, and similar structured and durable systems approved by the city engineer. Gravel, turf, or other materials that are not part of a structured system designed to manage stormwater are not allowed as surfacing material.

660-86.H MAXIMUM SURFACE AREA

All off-street parking areas and access drives must be designed using the smallest surface areas required for vehicular use. Areas outside of required drive aisles, parking spaces, sidewalks, and loading areas must be landscaped per 660-68.

660-86.I MARKING

In off-street parking areas for more than 4 vehicles, the location of each parking space must be identified by surface markings at least 4 inches in width and be maintained so as to be readily visible at all times.

660-86.J DRAINAGE

Adequate provision must be made for the management of stormwater from parking areas in conformance with applicable stormwater management regulations.

660-86.K SETBACKS

All off-street parking areas must be so designed and constructed that parked vehicles are set back at least one foot from lot lines and at least 2 feet from principal buildings.

660-86.L SIGHT TRIANGLES

Off-street parking is prohibited within the intersection and driveway visibility triangles established in 660-64.

660-86.M LIGHTING

All parking areas and related passageways and driveways associated with nonresidential uses and residential uses served by 20 or more parking spaces must be illuminated during hours of operation. Outdoor lighting used to illuminate

off-street parking areas is subject to the light and glare performance standards of 660-77.J.

660-86.N TANDEM AND STACKED PARKING

- (1) Tandem parking spaces that involve the placement of one parking space behind another may be used to satisfy parking requirements for residential uses when the parking spaces are assigned to the same dwelling unit.
- (2) Stacked (in-line) parking areas with the placement of 2 or more parking spaces in a row directly behind one another so that one parking space is blocking access for other parking spaces may be used to satisfy off-street parking requirements for nonresidential uses when an attendant is on duty during all hours of operation of the subject use. Stacked parking areas are exempt from compliance with minimum parking stall and aisle width requirements.

660-86.O CURBS AND BARRIERS

All open off-street parking areas must provide a 6-inch curb or approved wheel barrier when abutting property lines or landscape areas. Required curbs and barriers for spaces abutting property lines must be placed to ensure that parked vehicles do not extend beyond property lines. Required curbs and barriers for spaces abutting landscape areas may be placed at the edge of the paved area.

660-86.P FRONT YARD COVERAGE

Total parking and driveway surface area in an N zone may not exceed more than 50% of any street (front or corner side) yard area.

660-87 Vehicle Stacking

660-87.A SPACES REQUIRED

In addition to the parking required for each use, stacking spaces must be provided in accordance with Table 660-12. As an alternative to using the stacking requirements of Table 660-12, the zoning officer and zoning hearing board are also authorized to require that the applicant provide a stacking study to determine appropriate stacking space requirements.

Table 660-12. Stacking Space Requirements

USE	MINIMUM SPACES (PER LANE)
Drive-up Windows	
Restaurant drive-up window	5
Other drive-up window [1]	4
Vehicle Service/Repair [2]	4

[1] Includes banks, pharmacies and similar uses with drive-up or drive-through service.

[2] Includes car washes; all forms of motor vehicle, boat, and trailer repair

uses involving the stacking or queuing of vehicles awaiting service.

660-87.B DIMENSIONS

Each lane of stacking spaces must be at least 8 feet in width and at least 17 feet in length. Stacking lanes for drive-up windows must be delineated with pavement markings.

660-87.C LOCATION AND DESIGN

Stacking lanes must be located on the subject property. They may not be located within required driveways, drive aisles, parking spaces, or loading areas and may not interfere with access to parking and ingress and egress from the street.

660-87.D PEDESTRIAN ACCESS

The principal pedestrian access to the entrance of the use from a public sidewalk may not cross stacking lanes.

660-88 Loading

660-88.A GENERAL

Every building with more than 4,000 square feet of floor area used for business, trade or industry and other uses involved in large volume receipt and distribution by vehicles of materials and merchandise must provide off-street loading space. As part of a permitted reuse of an existing building, where a nonconformity regarding off-street loading facilities of a proposed new use would be similar to the previous use, and there would not be a substantial increase in the need for off-street loading facilities from the previous use to the proposed use, then the existing amount of off-street loading facilities may be continued.

660-88.B NUMBER OF SPACES REQUIRED

Off-street loading spaces must be provided in accordance with the minimum ratios established in Table 660-13.

Table 660-13. Loading Ratios

FLOOR AREA (SQ. FEET)	MINIMUM NUMBER OF LOADING SPACES REQUIRED
Commercial Uses	
0-4,000	0
4,001-20,000	1
20,001-100,000	1 per 20,000 sq. ft. or fraction thereof
Over 100,000	5 spaces, plus 1 per 40,000 sq. ft. or fraction thereof in excess of 100,000 sq. ft.
Manufacturing & Industry (except as below)	1 per 10,000 sq. ft.
Warehousing & Distribution	1 per 5,000 sq. ft.

660-88.C DIMENSIONS

Loading spaces must have minimum dimensions of 12 feet by 50 feet for uses in the manufacturing & industry group and 12 feet by 35 feet for all other uses. All loading spaces must have a minimum overhead clearance of 15 feet.

660-88.D LOCATION

Vehicle maneuvering areas and loading and unloading activities for uses in the manufacturing & industry group must occur on-site (outside the public right-of-way), unless approved by special exception after review and recommendation by the department of public works. See also 660-12.1 for regulations governing allowed on-site loading location. All loading areas must be located to minimize conflicts with traffic along public streets and with dwellings.

660-88.E ENGINE IDLING

All loading spaces must be posted with signs prohibiting engine idling for more than 5 minutes.

660-88.F SURFACING

All loading areas and access drives must be surfaced and maintained with an asphaltic or Portland cement binder concrete or other dustless, all-weather surface approved by the city.

660-88.G LANDSCAPE BUFFERS

Off-street loading areas are subject to the buffer regulations of 660-72 and 660-73.

ARTICLE 9. SIGNS

660-89 General 9-2
660-90 Sign-Related Measurements 9-4
660-91 Regulations of General Applicability 9-6
660-92 Exempt Signs 9-7
660-93 N, MX-N, and GX-N Zones (General) 9-9
660-94 MX-N and GX-N Special Corridors 9-9
660-95 Signs in MX-D and GX-D Zones 9-9
660-96 Signs in MX-C, MX-S, GX-C, and IX Zones 9-11
660-97 Signs in IG and IM Zones 9-12
660-98 Signs in P Zones 9-12
660-99 Off-Premise Outdoor Advertising Signs 9-12
660-100 Dynamic Displays 9-13
660-101 Outdoor Entertainment Venue Signs 9-13
660-102 Alcohol and Tobacco Advertising 9-14
660-103 Administration 9-14
660-104 Nonconforming Signs 9-14

660-89 General

660-89.A FINDINGS

In conjunction with the adoption of the sign regulations of this article and the purposes and intentions set forth in 660-89.B and 660-89.C the city council makes all of the following findings:

- (1) The city has a substantial and compelling interest in regulating signs in a way that avoids or reduces the harms and hazards caused by signs and advancing the purposes set forth in 660-89.B.
- (2) Unlike oral speech, signs can obstruct views, distract motorists, displace alternative uses for land, contribute to visual clutter, and pose other problems that legitimately call for regulation.
- (3) Regulation of the size, height, number and spacing of signs throughout the city is necessary to protect the public safety, to assure compatibility of signs with surrounding land uses, to enhance the business and economy of the city, to protect public and private investments, to maintain the tranquil environment of residential areas, to promote industry and commerce, to eliminate visual clutter, to provide an aesthetically appealing environment, to provide ample, meaningful opportunities for persons who desire to display information on signs to have their information seen and understood, and to provide for the orderly and reasonable display of advertising and other messages for the benefit of the public.
- (4) The sign regulations of this article are not anticipated to entirely eliminate all of the harms that may be created by the installation and display of signs. Rather they strike an appropriate balance that preserves ample channels of communication by means of visual display while reducing and mitigating the extent of harms that may be caused by uncontrolled sign displays.
- (5) Some signs have a single targeted function that makes identifying them by name or description difficult if not impossible without referring to the sign's function. Whenever a sign is described, in part, by referring to the function it serves, the provisions of this section that limit such a sign are designed to be neutral with respect to the content of the speech appearing on the sign.
- (6) These regulations are not intended or designed to restrict or control signs for the purpose of promoting or stifling any messages that might appear on them.

660-89.B PURPOSE

The sign regulations of this article are intended to balance the following differing, and at times, competing goals:

- (1) To accommodate the effective use of signs as a means of identification and communication for businesses, organizations and individuals;
- (2) Promoting the aesthetic and environmental values of Allentown by providing for signs that serve as effective means of communication and do not impair the attractiveness of the city as a place to live, work, visit, and shop;
- (3) Protecting public investment in and the character and dignity of public buildings, streets, and open spaces;
- (4) Protecting the distinctive physical character of Allentown's unique natural features, neighborhoods, street patterns, architectural features, and natural and historic resources;
- (5) Ensuring that signs are designed and proportioned in relation to the structures to which they are attached, adjacent structures, and the streets on which they are located;
- (6) Enhancing public right-of-way and other public spaces by preserving views and fostering the unobstructed growth of trees;
- (7) Providing an environment that safeguards and enhances neighborhood livability and property values, and promotes the development of businesses in the city;
- (8) Reducing hazards to motorists, bicyclists, and pedestrians caused by visual distractions and obstructions; and
- (9) Providing broadly for the expression of individual opinions through the use of signs.

660-89.C INTENT

- (1) **Time, Place, and Manner Restrictions.** The regulations of this article are intended to regulate the composition, type, location, placement, height, size, quantity, illumination, duration, and manner of signs and advertising devices that may be displayed. The regulation of these aspects of signs and sign structures is a valid and lawful means of achieving the purposes of this article. These intentions and purposes are valid and lawful governmental interests.
- (2) **Content Neutrality.** The city intends to adopt and implement regulations that are content-neutral. It is not the intent to regulate the content of messages in any way. It is not the intent of this article to foreclose important and distinct mediums of expression for political, religious, or personal messages, on any sign permitted to be erected by this article. It is the intent of this article to allow political, religious, or personal (noncommercial) messages on any sign permitted to be erected by this article.

(3) **Extent.** The regulations of this article are considered no more extensive than necessary to serve the substantial public interests promoted by this article.

660-89.D APPLICABILITY

All signs on private property are subject to the sign regulations of this article and all other applicable provisions of this zoning ordinance except that the following signs are exempt from the sign regulations of this article:

- (1) Street address displays and building identification numbers that are essential to the location of properties and buildings;
- (2) Cemetery stones and markings of individual graves or burial plots;
- (3) Holiday decorations, provided that they are removed within 30 days of the holiday to which they pertain;
- (4) Official government flags;
- (5) Signs that are not legible to persons with 20:20 eyesight when viewed from a height of 4.5 to 5 feet above ground level of abutting properties or public rights-of-way;
- (6) Murals on building walls that contain no commercial message;
- (7) Official signs or governmental or court-issued notices;
- (8) Signs that are necessary to warn persons of significant threats on the premises to their physical safety;
- (9) Scoreboards that are part of a public or private recreational facility and that are oriented to be viewed by spectators within the facility; and
- (10) Official traffic control signs and other signs and devices installed under the authority of the state or a local government.

660-89.E SUBSTITUTION

- (1) Any sign allowed under this article may contain, in lieu of any other message or copy, any lawful noncommercial message that does not direct attention to a business operated for profit, or to a product, commodity or service for sale or lease, or to any other commercial interest or activity, as long as the sign complies with all size, height, location and other applicable requirements of this article.
- (2) The purpose of the substitution provisions of this section is to ensure “content neutrality,” thereby avoiding any inadvertent favoring of commercial speech over noncommercial speech, or favoring of any particular noncommercial message over any other noncommercial message.

(3) The substitution provisions of this section do not create a right to increase the total amount of signs on a lot or allow the substitution of an off-premises outdoor advertising sign for an on-premises sign.

660-89.F SIGN-RELATED DEFINITIONS

The definitions of this section apply in administering and interpreting the sign regulations of this zoning ordinance.

- (1) **Attached Sign.** A sign that is attached to a building, including wall signs, awning signs, suspended signs, and projecting signs.
- (2) **Awning Sign.** A sign that is mounted or printed on, or attached to, an awning, canopy, or marquee but that does not project above, below or beyond the awning, canopy or marquee.
- (3) **Banner.** A sign having characters, letters or illustrations applied to cloth, paper or fabric of any kind, with only such non-rigid material for background.
- (4) **Box Sign.** A sign that is self-enclosed in a cabinet, with or without internal lighting, whether single- or double-faced.
- (5) **Commercial Message.** Any wording, logo, or other graphic representation that directly or indirectly, names, advertises, or calls attention to a business, product, service or other commercial activity.
- (6) **Construction Sign.** A temporary sign located on a lot upon which permitted building or construction activity is actively occurring.
- (7) **Dwell Time.** The duration or interval of time during that each individual advertisement or message is displayed on any sign with a dynamic display.
- (8) **Dynamic Display.** Any element of a sign or sign structure capable of displaying words, symbols, figures, images or messages that can be electronically or mechanically changed by remote or automatic means, thereby presenting a series of images, messages, or displays.
- (9) **Feather Sign.** A lightweight, portable sign mounted along one edge on a single, vertical, flexible pole the physical structure of which may resemble a sail, bow, or teardrop.
- (10) **Flashing Sign.** An illuminated sign that is not kept constant in intensity at all times when in use, and that exhibits sudden or marked changes in lighting effects.
- (11) **Freestanding Sign.** An on-premises sign supported by, or suspended from, a freestanding column or other support located in the ground, and that is not attached to a building.

- (12) **Illuminated Sign.** A sign that has characters, letters, figures, designs or outlines illuminated by electric lighting or luminous tubes as part of the sign.
- (13) **Indirectly Illuminated Sign.** An illuminated, non-flashing sign whose illumination is derived from an external artificial source so arranged that no direct rays of light are projected from such artificial source into residential districts or public streets.
- (14) **Noncommercial Message.** Wording, logos, or other graphic representations that do not directly or indirectly, name, advertise, or call attention to a business, product, service or other commercial activity.
- (15) **Official Sign.** A sign erected by a federal, state, county or city agency, or specifically authorized by a city ordinance or resolution, and that exists for public purposes. Such signs include announcements of governmental funding.
- (16) **Off-Premises Outdoor Advertising Sign (Billboard).** A board, panel or tablet used for the display of advertising matter that directs attention to a business, product, service, or activity not conducted, sold or offered upon the premises where such sign is located.
- (17) **On-Premises Sign.** A sign that directs attention to a business, profession, product, service, or activity sold or offered upon the premises where such sign is located.
- (18) **Pennant.** Any lightweight plastic, fabric, or other material, whether or not containing a message of any kind, suspended from a rope, wire, or string, usually in a series, designed to move in the wind.
- (19) **Political Sign.** A temporary sign displayed on a lot during an active local, state, or federal campaign for public office or ballot issue or referendum.
- (20) **Portable Sign.** An on-premises sign that can be moved from place to place and that is not permanently located, or anchored, in the ground or permanently attached to a building. Examples include signs commonly known as reader boards, signs carried from place to place on a flatbed truck or trailer that are clearly intended for the purpose of advertising an event, business, product, or other use not associated with the operator of the vehicle, and hot air or gas-filled balloons or other figures tethered to the ground or a building.
- (21) **Projecting Sign.** An on-premises sign that is attached directly to an exterior wall and that extends more than 15 inches from the face of such wall.
- (22) **Real Estate Sign.** A temporary sign located on a lot or portion of a lot that is actively being marketed for sale, rental or lease.

- (23) **Roof Sign.** A wall or projecting signs that exceeds the height of the building to which it is attached. Signs mounted on a parapet wall that is an architectural extension of the facade are not considered roof signs if they have no visible support structures and do not extend more than 5 feet above the roof line of the building. Signs attached to a roof or parapet that do not meet the definition of a roof sign are regulated as attached signs.
- (24) **Sandwich Board Sign.** A movable A-frame or T-frame sign that advertises a commercial business located on the premises, and is placed outside only when the business is open. For purposes of this zoning ordinance, a sandwich board sign is not considered a temporary or portable sign.
- (25) **Sign.** Any name, identification, description, display, illustration or device that is affixed to or represented directly or indirectly upon a building, structure or land in view of the general public, and that directs attention to a product, place, activity, person, institution, business or idea.
- (26) **Suspended Sign.** A sign that is suspended from the underside of a horizontal plane surface, such as a canopy or marquee, and is supported by such surface.
- (27) **Temporary Sign.** A sign, banner, or advertising display constructed of cloth, canvas, fabric, plywood or other light material and designed or intended to be displayed for a short period of time.
- (28) **Wall Sign.** An on-premises sign that is attached to the wall of a structure with the face in a plane parallel to such wall, and not extending more than 15 inches from the face of such wall.
- (29) **Window Sign.** An on-premises sign that is attached to, painted on or readable through an exterior window or door.

660-90 Sign-Related Measurements

660-90.A SIGN AREA

- (1) **Flat Wall Signs and Signs Enclosed in Frames or Cabinets.** The area of a flat wall sign or sign enclosed in a frame, box or cabinet is based on the outer dimensions of the sign, or the frame or cabinet surrounding the sign face.
- (2) **Channel (Individual) Letter Signs.** The area of a sign comprised of individual letters or elements attached directly to a building wall is determined by calculating the area of the smallest contiguous perimeter around the letters or sign copy area.
- (3) **Painted Wall Signs.** The area of a painted wall sign is measured in the same manner as a channel letter sign.

- (4) **Non-Planar Signs.** Spherical, free-form, sculptural or other non-planar sign area is measured as 50% of the sum of the areas using only the 4 vertical sides of the smallest four-sided rectangle that will encompass the sign structure.
- (5) **Multi-Sided Signs.** Unless otherwise expressly stated, when the sign faces of a multi-sided sign are parallel or within 30 degrees of parallel, only one side is counted for the purpose of determining the area and number of signs. If the sign faces are not parallel or within 30 degrees of parallel, each sign face is counted as a separate sign. If the size of one sign face is larger than another, the size of the largest sign face is the area of the sign.

660-90.B SIGN HEIGHT

The height of a freestanding sign is measured as the vertical distance from ground level to the top of the sign. The height of a freestanding sign includes the sign base.

660-90.C SETBACK AND SEPARATION DISTANCES

Unless otherwise expressly stated, required setback, spacing and separation distances between signs must be measured in a straight line from the nearest points on the respective signs or sign structures. Required separation distances between signs and zones, areas, or lots must be measured in a straight line from the nearest point on the sign face to the nearest point of the subject zone, area, or lot.

660-90.D ILLUMINATION AND LUMINANCE

For the purpose of verifying compliance with maximum brightness level limits expressed in nits (candelas per square meter), brightness levels must be measured with the dynamic display set to run full white copy with a luminance meter positioned at a location perpendicular to the sign face center. When taking the luminance reading, the sign face must be the only subject visible in the viewfinder.

660-90.E WINDOW AREA

The area of a window includes only the glass or glazed elements of the window. Frames, mullions, and similar features are not counted as part of the window area.

660-90.F BUILDING FRONTAGE

Many of the sign regulations of this article are based on building frontage. The following rules govern the measurement of building frontage.

- (1) For buildings occupied by a single tenant or multiple tenants that access the building via a common entrance, building frontage is the exterior building wall that: (1) is



Figure 660(28) Channel Letter and Painted Wall Sign Measurement

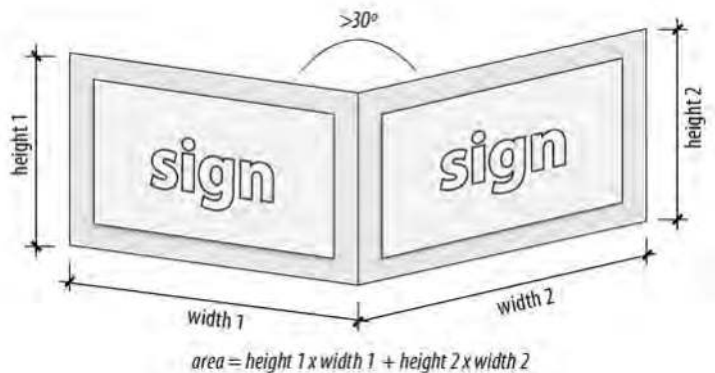
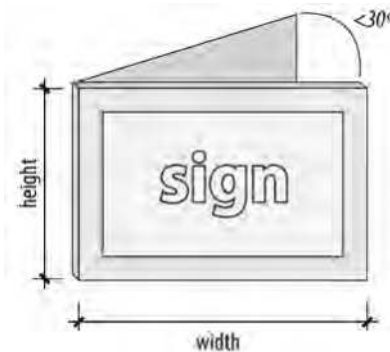

Figure 660(30) Multi-Sided Sign Measurement

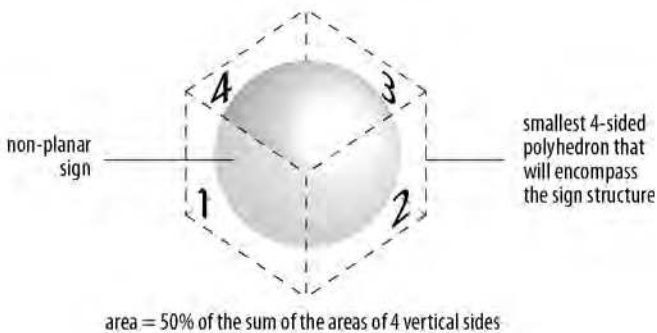

Figure 660(29) Non-Planar Sign Measurement

adjacent to a street, alley, parking area or other vehicle circulation area that is accessory to and serves the subject building and (2) contains either windows or a public building entrance. Allowed attached sign area for a building that has 2 or more building frontages must be calculated on the basis of each individual building frontage. Allowed sign are derived from one building frontage may not be assigned to another building frontage.

- (2) On buildings occupied by more than one tenant where each tenant has their own outside entrance, a tenant's building frontage is the exterior building wall (or walls) that directly abut the tenant's interior floor space and that: (1) abuts, parallels, or is the nearest to parallel with a street, alley, parking area or other vehicle circulation area that is accessory to and serves the subject building and (2) contains either windows or a public building entrance. A tenant that has 2 or more building frontages must calculate the permitted sign area on the basis of each individual building frontage. Allowed sign are derived from one building frontage may not be assigned to another building frontage.
- (3) Regardless of the height, number of stories, or number of tenants in a building, building frontage is determined by one measurement of the horizontal length of the wall at finished grade. Building walls must be measured along a flat, unbroken plane, regardless of the presence of recesses or projections along the building wall.
- (4) As an alternative to the allocation of permitted sign area on the basis of individual building frontages, a differing allotment of sign area may be assigned to the various tenants upon approval of the zoning officer. In no instance may the total combined sign area for all signs exceed the maximum allowed sign area for the individual building frontages, as determined in accordance with building frontage measurement rules of this section.

660-91 Regulations of General Applicability.....

660-91.A OFF-PREMISES OUTDOOR ADVERTISING SIGNS

Off-premises outdoor advertising signs are allowed only in those locations expressly identified in this zoning ordinance and only when such signs comply with all applicable regulations. Provisions of this zoning ordinance that refer to "signs" being allowed or certain types of signs being allowed (e.g., freestanding, wall, projecting) are not to be construed as references to off-premises outdoor advertising signs being allowed, unless the subject provision expressly refers to "off-premises outdoor advertising signs."

660-91.B PROHIBITED SIGNS

The following signs and sign characteristics are prohibited:

- (1) Signs for which a required permit has not been issued or that are posted or maintained in violation of the sign regulations of this article;
- (2) Signs located in such a manner as to constitute a nuisance, as provided in the municipal code;
- (3) Signs erected on public or private property (including rights-of-way) without the permission of the owner;
- (4) Roof signs;
- (5) Search lights, strobe lights, rotating beacon lights, flashing lights, and flashing, blinking, mechanically moving, twinkling or animated signs that are visible from public right-of-way, except as otherwise expressly allowed by this article or required by law (this prohibition is not intended to apply to dynamic (sign) displays that do not flash or to off-premises outdoor advertising "tri-vision" signs located within 200 feet of and oriented to be viewed from the right-of-way Interstate Route 78 or United States Route 22);
- (6) Off-premises outdoor advertising signs other than those expressly permitted by the regulations of this article;
- (7) Signs stating or implying that property may be used for a purpose prohibited by this zoning ordinance.
- (8) Feather signs, spinners, pennants, or any moving object used for attention-getting purposes, whether containing a commercial message or not, except that pennants are allowed for outdoor vehicle sales uses;
- (9) Signs that obstruct vehicular or pedestrian access or circulation, or that pose any other hazard to motorized or nonmotorized travel;
- (10) Signs that obstruct any fire escape, required exit, window or door opening used as a means of egress;
- (11) Signs that obstruct, impair, obscure, interfere with the view of, or that emulate or may be confused with, any authorized traffic control sign, signal, or device;
- (12) Derelict signs and signs constructed or composed of scrap metal, pallets, or other junk material;
- (13) Signs in violation of the visibility triangle regulations of 660-64; and
- (14) Any other sign or advertising device expressly prohibited by provisions of this zoning ordinance.

660-91.C SIGNS IN RIGHT-OF-WAY

The regulations of this subsection apply to all signs except as expressly allowed by the building code or a city-approved encroachment permit.

- (1) Allowed wall, awning, and projecting signs that project over the public right-of-way must have a minimum vertical clearance of 8 feet above the level of the sidewalk or the ground immediately below the sign. Signs may not project over a street or alley cartway.
- (2) Signs may not project more than 36 inches into the public right-of-way. This provision does not apply to allowed awning signs.
- (3) Sign posts or other sign supports may not be erected within a public street right-of-way.

660-91.D MOUNTED HEIGHT OF WALL AND PROJECTING SIGNS

Wall and projecting signs may not exceed the height of the structure upon which they are attached. Signs may be placed on a parapet wall that is an architectural extension of the facade, provided the sign does not extend more than 5 feet above the roof line of the structure and any sign support structures are not visible. All projecting signs must have a minimum vertical clearance of 8 feet above the level of the sidewalk or the ground immediately below the sign.

660-92 Exempt Signs

The signs allowed under the regulations of this section do not require zoning permits and are not counted as signs for purposes of determining the number of signs or area of signs allowed on a lot. These signs are allowed in addition to the signs allowed in specific zones under the regulations of [660-93](#), [660-94](#), [660-95](#), [660-96](#), [660-97](#), and [660-98](#).

660-92.A INTEGRAL SIGNS

Non-illuminated signs carved, extruded, or embedded into the subject building or made of bronze, aluminum, or other similar permanent material and made an integral part of the building to which they are attached are allowed in all zones. Such signs may not exceed 4 square feet in area.

660-92.B REAL ESTATE SIGNS

One real estate sign is allowed per street frontage. Such signs may not exceed:

- (1) 32 square feet in area or 8 feet in height on lots occupied by nonresidential uses or buildings containing 3 or more dwelling units; or
- (2) 8 square feet in area or 6 feet in height on lots occupied by fewer than 3 dwelling units.

660-92.C CONSTRUCTION SIGNS

One temporary construction sign is allowed per street frontage. Such signs may not exceed:

- (1) 32 square feet in area or 8 feet in height on lots occupied by nonresidential uses or buildings containing 3 or more dwelling units; or

- (2) 8 square feet in area or 6 feet in height on lots occupied by fewer than 3 dwelling units.

660-92.D SMALL ATTACHED SIGNS

Small attached signs are allowed in all zones, provided such signs do not exceed 2 square feet in area in N zones or 4 square feet in area in all other zones.

660-92.E SIGNS OF HISTORIC OR CULTURAL SIGNIFICANCE

The zoning officer is authorized to permit the preservation, maintenance, and restoration of painted wall signs on older buildings (often referred to as "ghost signs") when such signs are determined by the zoning officer to have historical, architectural, or cultural significance. Like other "exempt" signs under this section, such signs are not counted as signs for purposes of determining the number of signs or area of signs allowed on a lot and are allowed in addition to any on-premises or off-premises signs allowed in subject zone.

660-92.F SIGNS APPURTENANT TO DRIVEWAYS

- (1) One sign may be installed at each driveway serving a lot occupied by an allowed nonresidential use or residential use with more than 15 dwelling units or 50 residents. Such signs may not exceed 4 square feet in area or 5 feet in height and must comply with the intersection and driveway visibility triangle requirements of [660-64](#).
- (2) Off-street parking areas with a capacity of more than 10 vehicles, multi-tenant developments and uses on lots exceeding 20,000 square feet in area may display internal site driveway signs. Such signs must be located within 10 feet of an internal site driveway or drive aisle and may not exceed 12 square feet in area or 8 feet in height.

660-92.G FLAGS

A maximum of 4 flags may be displayed on any lot. Individual flags allowed under this provision may not exceed 16 square feet in area (pursuant to [660-89.D](#)). Official government flags are exempt from regulation under this zoning ordinance.

660-92.H BANNERS

Banners are permitted in mixed-use, industrial and civic-institutional zones, provided that they:

- (1) Are attached to a building or suspended from some part of a building.
- (2) Do not exceed 64 square feet in area.
- (3) Are displayed for no more than 2 periods of 15 consecutive days each during any 12-month period.

660-92.I SANDWICH BOARD SIGNS

One non-illuminated sandwich board sign is allowed per ground floor tenant, subject to the following regulations:

- (1) Sandwich board signs are prohibited in N zones.
- (2) Sandwich board signs may have a maximum of 2 faces, with a maximum of 6 square feet per side, and a maximum height of 3 feet.
- (3) Sandwich board signs must be placed against the side of a building or along the curb so that at least 5 feet of the sidewalk remains continuously clear. If sandwich board is placed within the street right-of-way, an encroachment permit is required.
- (4) Sandwich board signs must be taken indoors during hours when the use is not open to the public.
- (5) Sandwich board signs may not use electrical wiring.

660-92.J WINDOW SIGNS

Non-illuminated signs displayed inside a window or on a window (decal or painted) and neon signs displayed inside a window are allowed in all zones. Such signs may not cover more than 25% of the subject window area. Window areas included in doors are subject to this regulations and are included in calculation of maximum allowed coverage. Internally illuminated window signs in excess of 2 square feet in area are regulated in the same manner as wall signs, and are counted towards the maximum sign area and number limits for wall signs.

660-92.K DRIVE-THROUGH FACILITIES

Signs appurtenant to drive-through facilities are permitted on the site of any allowed drive-through facility, subject to the regulations of this subsection.

- (1) **Location.** Signs appurtenant to drive-through facilities must be located within 10 feet of a drive-through lane.
- (2) **Number and Dimensions.** One primary drive-through sign not to exceed 36 square feet in area or 8 feet in height is allowed per order station up to a maximum of 2 primary drive-through signs per lot. One secondary drive-through sign not to exceed 15 square feet in area or 6 feet in height is allowed per lot.
- (3) **Residential Separation.** Signs appurtenant to drive-through facilities must be set back at least 25 feet from N-zoned lots.
- (4) **Visibility.** Drive-through signs must be oriented to be visible by motorists in allowed drive-through lanes.

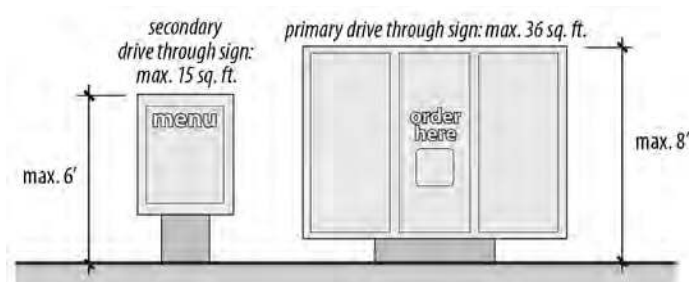

Figure 660(27) Drive-Through Signs

660-92.L PORTABLE SIGNS

Portable signs are permitted in mixed-use and industrial zones, provided that they:

- (1) Do not exceed 6 feet in height, measured from grade;
- (2) Do not exceed 32 square feet in area;
- (3) Are constructed of a durable material and weighted or anchored to provide stability;
- (4) Comply with applicable provisions of the City Electrical and Building Codes;
- (5) Are displayed for no more than 2 periods of 15 consecutive days each during any 12-month period.

660-92.M SUSPENDED SIGNS

A maximum of one suspended sign is permitted per ground floor tenant building frontage. Such suspended signs may not exceed 6 square feet in area and must provide a minimum vertical clearance of 9 feet above the ground surface below. Suspended signs are considered exempt signs under this section only when attached to the underside of awnings, canopies, or other walkway overhangs.

660-92.N TEMPORARY SIGNS

Signs that meet the definition of a "temporary sign" are allowed as follows:

- (1) Such signs are permitted on a lot with a principal nonresidential use, or on a vacant lot in a non-N zone, except for political signs, which are allowed in all zones.
- (2) Except for political signs, such signs may be displayed for a maximum of 52 days per calendar year.
- (3) The total sign area of all freestanding temporary signs on a lot may not exceed 32 square feet. The total sign area of all temporary signs attached to a building may not exceed 64 square feet.
- (4) Exceptions to the number, size, or duration limitations of this section may be approved in accordance with the special exception procedures of 660-110.

660-92.O GOVERNMENTAL INTEREST SIGNS

Signs necessary to serve compelling governmental interests in protecting or promoting public health, safety, traffic safety; complying with legal requirements; serving the needs of emergency responders; and protecting property rights or the rights of persons on property are allowed in all zones, including the following:

- (1) When a federal, state or local law requires a property owner to post a sign on the owner's property to warn of a danger or to prohibit access to the property either generally or specifically, the owner or occupant must comply with the federal, state or local law by posting the required sign on the property. If the federal, state, or

local regulation describes the form and dimensions of the sign, the property owner or occupant must comply with those requirements, otherwise, when not defined, the sign may not be larger than 4 square feet in area.

- (2) Official notices or advertisements posted or displayed by or under the direction of any public or court officer in the performance of official or directed duties; provided, that such signs must be removed by the property owner or occupant no more than 10 days after their purpose has been accomplished or as otherwise required by law.

660-93 N, MX-N, and GX-N Zones (General)

660-93.A APPLICABILITY

The regulations of this section apply in all N, MX-N, and GX-N zones outside of the special corridors identified in 660-94. They also apply to lots occupied by single-purpose residential buildings in all other zones.

660-93.B PERMITTED SIGN TYPES

Attached signs and freestanding signs are permitted in N, MX-N, and GX-N zones, in addition to those exempt signs specified in 660-92). All other sign types are prohibited unless otherwise expressly stated.

660-93.C NUMBER, AREA, AND HEIGHT

The maximum number, area and height of signs allowed in N, MX-N, and GX-N zones (outside of the special corridors identified in) may not exceed the limits established in Table 660-14.

Table 660-14. Signs in N, MX-N, and GX-N Zones

Principal Use	Maximum		
	No. Permitted	Area (sq. ft.)	Height (ft.)
Household Living			
1 – 4 units	Only those exempt signs allowed under 660-92		
5 – 11 units	1 per street frontage	20	6
12+ units	1 per street frontage	50	6
Group Living			
1 – 12 residents	Only those exempt signs allowed under 660-92		
13 – 49 residents	1 per street frontage	20	6
50+ residents	1 per street frontage	50	6

660-93.D ADDITIONAL REGULATIONS

(1) Illumination

- (a) Signs on N-, MX-N-, and GX-N-zoned lots may be illuminated only by external lighting, not by a light source that is contained within the sign.
- (b) Dynamic displays are expressly prohibited in N, MX-N, and GX-N zones.

- (2) **Setbacks.** Permanent freestanding signs allowed in N, MX-N, and GX-N zones must be set back at least 10 feet from all street rights-of-way.

660-94 MX-N and GX-N Special Corridors

660-94.A APPLICABILITY

The regulations of this section apply to lots in MX-N and GX-N zones with frontage on North 7th Street or North 19th Street except that lots occupied by single-purpose residential buildings are subject to the sign regulations that apply in N, MX-N, and GX-N zones (see 660-93).

660-94.B PERMITTED SIGNS

- (1) Each principal use is permitted one wall, awning or projecting sign per street frontage. The total sign area of all such signs on a lot may not exceed 40 square feet per building frontage. A projecting or awning sign may project up to 6 feet from the face of a building, provided all other requirements are met.
- (2) On lots occupied by buildings that are set back at least 20 feet from the street right-of-way, a single freestanding sign is permitted. Such sign may not exceed 10 feet in height or 20 square feet in area. The allowed freestanding sign must be set back from the property line for a distance equal to at least 50% of the minimum required street setback or minimum build-to zone setback.
- (3) One sandwich board sign is allowed per building. Such sign may have no more 2 faces, with a maximum of 6 square feet per side. The maximum height may not exceed 3 feet. Sandwich board signs must be placed against the side of a building or along the curb so that at least 5 feet of sidewalk area remains continuously clear. The sign must be taken indoors during hours when the use is not open to the public. If such sandwich board is placed within the street right-of-way, an encroachment permit is required. Sandwich board signs may not use electrical wiring.

660-95 Signs in MX-D and GX-D Zones

660-95.A APPLICABILITY

Lots occupied by single-purpose residential buildings in MX-D and GX-D zones are subject to the sign regulations that apply in N, MX-N, and GX-N zones (see 660-93). All other lots in MX-D and GX-D zones are subject to the regulations of this section.

660-95.B ATTACHED SIGNS

- (1) Buildings in MX-D and GX-D zones may include one or more wall, awning or projecting on-premises signs. A projecting or awning sign may project up to 6 feet from

the face of a building, provided all other requirements are met.

- (2) The total area of attached signs may not exceed 3 square feet per linear foot of building frontage, not to exceed 300 square feet of sign area per building frontage.
- (3) For walls of buildings that do not have frontage on a street but have entrance facades or frontage on an alley, the total area of allowable wall signs may not exceed one square foot per linear foot of building frontage, not to exceed 100 square feet of sign area per building frontage. This provision does not apply to single-purpose residential buildings.

660-95.C LIVE ENTERTAINMENT VENUE SIGNS

If a building primarily provides for live entertainment uses for 500 or more customers at a time, then a total of 2 dynamic displays are allowed on the building subject to the following:

- (1) Dynamic display signs are prohibited within 200 feet of any N-zoned lot, except that this separation distance requirement does not apply if dynamic display is not visible from the N-zoned lot. Required separation distances must be measured horizontally in a straight line from the nearest point on a sign face to the nearest point of the protected lot.
- (2) The building must occupy a lot with frontage on Hamilton Street between 5th Street and 10 Street.
- (3) The total area of dynamic displays may not exceed a cumulative sign area of 1,000 square feet and be attached to a building wall or marquee that primarily faces Hamilton Street.
- (4) Dynamic displays are subject to the regulations of 660-100.
- (5) Signs with allowed dynamic displays may encroach over a public sidewalk in a marquee-type design upon issuance of an encroachment permit.

- (6) While dynamic display signs are primarily intended to accommodate on-premises advertising, they may also include off-premises advertising.

660-95.D SIGN DESIGN

The following sign regulations apply within MX-D and GX-D zones in recognition of the historical significance of these areas of the city.

(1) Awning Signs

- (a) Awnings must be constructed of fabric or other durable, flexible material that has the appearance of fabric. Vinyl, plastic or aluminum awnings are expressly prohibited.
- (b) Awnings must be shed style (having a straight slope), either fixed or retractable. Dome or bubble-shaped awnings are expressly prohibited.
- (c) The shape of the awning framework must match the shape of the upper frame of the window or door opening.
- (d) Any illumination of an awning sign must be indirect, from an overhead light source. Interior illumination of awning signs is expressly prohibited.

(2) Wall Signs

- (a) Wall signs must be flush-mounted to the building. Box signs with interchangeable or plexiglass faces are expressly prohibited.
- (b) Lettering and symbols on wall signs may be painted, carved, raised, mounted or created with neon tubing. Vinyl sheeting is prohibited on walls facing Hamilton Street.
- (c) Wall signs located in the sign zone (as described below) between the first and second floors must be placed as follows:



Figure A

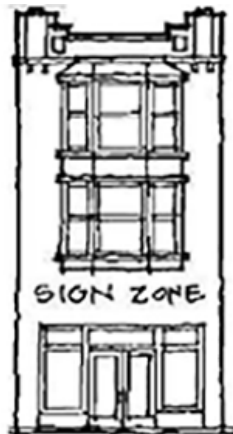

Figure B

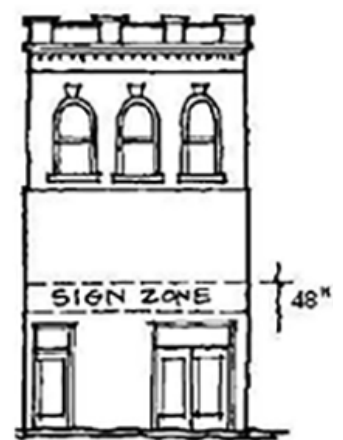

Figure C

660-96 Signs in MX-C, MX-S, GX-C, and IX Zones

- [1] If there is a defined cornice, the sign must be centered vertically within the cornice (see Figure A).
- [2] If there is not a defined cornice, the sign must be centered vertically between the windows of the first and second stories (see Figure B).
- [3] If there are no windows on the second story, the sign must be placed such that the top of the sign zone is no more than 48 inches above the top of the first-story windows (see Figure C).

- (d) Wall signs may only be illuminated indirectly from an overhead light source. Interior illumination or backlighting of wall signs is expressly prohibited except where the sign consists of individual letters or has letters cut out of the main surface of the sign. Neon lighting or signs using similar gases may be permitted as a frame around the outside of a wall sign, but not as a frame around an entire window or building.

(3) Window Signs

- (a) Permanent window signs must consist of painting, etching, vinyl sheeting or lettering on the glass surface of a window. Paper or cardboard signs are expressly prohibited.
- (b) Permanent window signs may occupy no more than 60% of the window area on first floor windows and no more than 30% of the window area on upper floor windows.
- (c) Temporary window signs may occupy no more than 10% of the window area.

(4) Projecting Signs

- (a) Projecting signs must be constructed of wood or metal and must be mounted to the wall using a simple or ornamental pole or bracket.
- (b) Lettering and symbols on projecting signs must be painted, carved, raised, mounted or created with neon tubing. Vinyl sheeting is prohibited on walls facing Hamilton Street.

- (5) **Sandwich Board Signs.** Portable sandwich board signs must be constructed of wood or metal or of a material that has the appearance of wood or metal.

(6) Freestanding Signs

- (a) Freestanding signs are limited to monument-style signs affixed directly to the ground. Pole-style signs attached to the ground by a column or pole are expressly prohibited.

- (b) Freestanding signs must be constructed of wood, metal, masonry or stone or of a material that has the appearance of wood, metal, masonry or stone.
- (c) Lettering and symbols on freestanding signs must be painted, carved, raised, or mounted.
- (d) Freestanding may not exceed 8 feet in height or 32 square feet in area.

660-96 Signs in MX-C, MX-S, GX-C, and IX Zones

660-96.A APPLICABILITY

Lots occupied by single-purpose residential buildings in MX-C, MX-S, GX-C, and IX zones are subject to the sign regulations that apply in N, MX-N, and GX-N zones (see 660-93). All other lots in MX-C, MX-S, GX-C, and IX zones are subject to the regulations of this section.

660-96.B ATTACHED SIGNS

- (1) Buildings in MX-C, MX-S, GX-C, and IX zones may include one or more wall, awning or projecting on-premises signs. A projecting or awning sign may project up to 6 feet from the face of a building, provided all other requirements are met.
- (2) The total area of attached signs may not exceed 2 square feet per linear foot of building frontage, not to exceed 300 square feet of sign area per building frontage.

660-96.C FREESTANDING SIGNS

- (1) **Multi-Tenant Shopping Centers.** Lots occupied by multi-tenant shopping centers are allowed a maximum of one freestanding sign with a maximum sign area of 300 square feet and a maximum height of 25 feet.
- (2) **Other.** Lots occupied by a principal building that is not on the same lot as a multi-tenant shopping center area allowed a maximum of one freestanding sign with a maximum height of 25 feet and a maximum area of:
 - (a) 150 square feet if located on a separate lot of 4 acres or greater; or
 - (b) 75 square feet in all other cases.

660-96.D OFF-PREMISE OUTDOOR ADVERTISING SIGNS

Off-premise outdoor advertising signs are allowed only on IG- or IM-zoned lots or on lots that were classified in the B-3 zoning district on the day before the effective date specified in 660-01.C. Such signs are subject to the regulations of 660-99.

660-97 Signs in IG and IM Zones

660-97.A APPLICABILITY

The regulations of this section apply in all IG and IM zones.

660-97.B ATTACHED SIGNS

- (1) Buildings in IG and IM zones may include one or more wall, awning or projecting on-premises signs. A projecting or awning sign may project up to 6 feet from the face of a building, provided all other requirements are met.
- (2) The total area of attached signs may not exceed 2 square feet per linear foot of building frontage, not to exceed 300 square feet of sign area per building frontage.

660-97.C FREESTANDING SIGNS

A maximum of one freestanding sign is permitted per lot with a maximum sign area of 150 square feet and a maximum height of 20 feet.

660-97.D OFF-PREMISE ADVERTISING SIGNS

Off-premise outdoor advertising signs are allowed only on lots that were classified in the B-3, I-2, or I-3 zoning district on the day before the effective date specified in 660-01.C. Such signs are subject to the regulations of 660-99.

660-98 Signs in P Zones

660-98.A APPLICABILITY

The regulations of this section apply in all P zones.

660-98.B PERMITTED SIGN TYPES

Wall signs and freestanding signs are permitted in P zones, in addition to those exempt sign types specified in 660-92. All other sign types are prohibited.

660-98.C NUMBER, AREA, AND HEIGHT

- (1) **Hospitals.** Sites occupied by hospitals are allowed a total maximum (cumulative) sign area of 300 square feet per street frontage.
- (2) **Other Uses.** The following regulations apply on P-zoned lots occupied by uses other than hospitals:
 - (a) On lots with an area of one acre or more, a maximum of 3 signs are allowed per street frontage. Such signs may be attached or freestanding, with a maximum area of 50 square feet each. Freestanding signs may not exceed 8 feet in height.
 - (b) On lots with an area of less than one acre, a maximum of 1 sign is allowed per street frontage. Such sign may be attached or freestanding, with a maximum area of 50 square feet. Freestanding signs may not exceed 8 feet in height.

660-99 Off-Premise Outdoor Advertising Signs

Off-premise outdoor advertising signs, where allowed, are subject to the following regulations:

- (1) Each off-premise outdoor advertising sign structure may have sign faces on 2 sides, and each side may include multiple sign faces. Off-premises advertising sign may not have more than 2 sides.
- (2) Off-premise outdoor advertising signs are limited to a maximum height of 30 feet. However, for off-premise outdoor advertising signs located adjacent to and directed toward an interstate highway and where the lot is below the grade of the highway that the sign is directed towards, then the total maximum height may be 25 feet above the grade of the highway centerline.
- (3) Off-premise outdoor advertising signs are subject to the setback requirements that apply to principal buildings in the subject zone.
 - (a) Additionally, off-premises outdoor advertising sign must be set back at least:
 - [1] 300 feet from any N-zoned lot; and
 - [2] 300 feet from any other off-premise outdoor advertising sign.
 - (b) Additionally, if an off-premises sign, or any portion thereof, includes a dynamic display, the sign must be set back at least 1,000 feet from any other off-premise outdoor advertising sign that includes a dynamic display.
- (4) Off-premise outdoor advertising signs may not exceed a total area of 300 square feet, except when such sign is located within 200 feet of the right-of-way of and intended or designed to be viewed from Interstate Route 78 or United States Route 22, in which case the maximum sign area allowed is 672 square feet.
- (5) An existing off-premise outdoor advertising sign may be converted to a dynamic display only if:
 - (a) The dynamic display complies with the regulations of 660-100; and
 - (b) The off-premises outdoor advertising sign would be able to meet all of the current requirements that apply to off-premise outdoor advertising signs as if the outdoor advertising off-premises sign would be newly placed on the property.
- (6) A portable or projecting sign may not be used for off-premises outdoor advertising.

660-100 Dynamic Displays

- (1) **Display Type.** Dynamic displays may not display full-motion video or otherwise use multiple pictures or graphics in a series of frames to give the illusion of motion or video.
- (2) **Dwell Time.** The images and messages displayed on dynamic displays located within 200 feet of the right-of-way of, and intended or designed to be viewed from Interstate Route 78 or United States Route 22 must have a minimum dwell time of at least 6 seconds before changing to the next image or message. The images and messages displayed on all other dynamic displays must have a minimum dwell time of at least 10 seconds before changing to the next image or message.
- (3) **Transition.** The transition or change from one message to another on an dynamic display must occur within one second and involve no animation or special effects.
- (4) **Illumination**
 - (a) The brightness of any dynamic display may not exceed a maximum illumination of 5,000 candelas per square meter (nits) during daylight hours and a maximum illumination of 500 candelas per square meter (nits) between dusk and dawn, as measured from the brightest element on the sign’s face.
 - (b) Dynamic displays must be equipped with a light detector or photocell that automatically adjusts the display’s brightness according to natural ambient light conditions.
- (5) **Separation from N Zones.** Except as more specifically regulated under the provisions of this article, dynamic display signs are prohibited within 50 feet of any N-zoned lot, except that this separation distance requirement does not apply if dynamic display is not visible from the N-zoned lot. Required separation distances must be measured horizontally in a straight line from the nearest point on a sign face to the nearest point of the protected lot.
- (6) **Future Amendments.** The city reserves the right to amend the dwell time and illumination regulations of this section. Approval of an dynamic display does not establish a right for continued operation of the dynamic display in accordance with the dwell time and illumination regulations then in effect before such an amendment.
- (7) **Acknowledgment.** No permit may be issued for a new dynamic display without a written acknowledgment by the owner or tenant of the premises that they have received notice that the future use of the sign is subject to all applicable future amendments of dwell time and illumination regulations.

660-101 Outdoor Entertainment Venue Signs

660-101.A APPLICABILITY

The regulations of this section apply to signs on lots occupied by outdoor spectator entertainment uses that include more than 7,000 fixed seats and that are not located on lots that abut or are across the street from an N or P1 zone.

660-101.B INTERNAL SIGNS

Signs located entirely within the outer walls of the facility occupied by the outdoor spectator entertainment use and that are oriented to be seen by spectators are not subject to the sign regulations of this article regardless of whether such signs are visible from outside the facility.

660-101.C FREESTANDING SIGNS

- (1) Freestanding signs are allowed at each entrance to the outdoor spectator entertainment site. Such signs may be erected on the premises or at off-premise locations for which easements have been obtained from the subject property owner.
- (2) The maximum sign area of one of the allowed freestanding signs may be up to 150 square feet, with all additional freestanding signs subject to a maximum sign area of 50 square feet each.
- (3) Freestanding signs may include a dynamic display.
- (4) Freestanding signs may not exceed 25 feet in height above the elevation of the street centerline, and must be erected either with the bottom of the sign at least 10 feet above the elevation of the street centerline or be set back at least 15 feet from the street property line.

660-101.D BANNERS

Banners may be displayed in associated parking lot areas, including private access roads to the parking lot. Such banners may not exceed a maximum size of 2.5 feet by 6.5 feet. Off-premises advertising is limited to 33% of the banner area.

660-101.E WALL SIGNS

The total cumulative area of all exterior wall signs may not exceed 1,000 square feet.

660-101.F EXTERIOR SURFACES

- (1) The venue may have a maximum of 30 signs on the exterior facing surfaces of inward facing advertising panels consisting of printed or painted graphics and off-premises advertising. The total cumulative areas of such signs may not exceed 6,000 square feet and may not be internally illuminated. Advertising is limited to no more than 25% of the total sign area. Not more than 2 individual signs on which off-premises advertising covers 100% of the display area may be placed adjacent to

one another, and in no case may the area of any single advertising panel exceed 400 square feet.

- (2) The venue may have signs consisting of printed or painted graphics and/or off-premises advertising on exterior-facing surfaces of the scoreboard and the speed of pitch display. The maximum sign area for the scoreboard and the speed of pitch display may not exceed 4,000 square feet and may not be internally illuminated. Off-premises advertising is limited to 25% of the display area.

660-102 Alcohol and Tobacco Advertising

660-102.A ALCOHOL ADVERTISING

- (1) No person may place any sign, poster, placard, device, graphic display, or other form of advertising that advertises alcoholic beverages in a publicly visible location within 300 feet of the property line of the following protected uses: schools, playgrounds, youth athletic fields, day care centers, amusement arcades and youth centers.
- (2) For purposes of this section, “publicly visible locations” include all off-premises outdoor advertising signs and all on-premises wall, projecting, and freestanding signs. The alcohol advertising regulations of this section do not apply to the placement of signs including advertisements in the following instances:
 - (a) Inside any premises selling alcoholic beverages including interior window signs; or
 - (b) On commercial vehicles used for transporting alcoholic beverages;
 - (c) Temporary or portable signs in conjunction with a city approved special event.
 - (d) Any sign that contains a generic description of alcohol products.

660-102.B TOBACCO ADVERTISING

- (1) No person may place any sign, poster, placard, device, graphic display, or other form of advertising that advertises tobacco products in a publicly visible location within 300 feet of the property line of the following protected uses: schools, playgrounds, youth athletic fields, day care centers, amusement arcades and youth centers.
- (2) For purposes of this section, “publicly visible locations” include all off-premises outdoor advertising signs and all on-premises wall, projecting, and freestanding signs. The tobacco advertising regulations of this section do not apply to the placement of signs including advertisements in the following instances:

- (a) Inside any premises selling cigarettes or tobacco products including interior window signs; or
- (b) Any sign that contains a generic description of tobacco products.

660-102.C SEPARATION DISTANCES

Required separation distances must be measured horizontally in a straight line from the nearest point on a sign face to the nearest point of the lot occupied by a protected use.

660-102.D EXISTING ADVERTISING

If a protected use is established within 500 feet of lawfully established alcohol or tobacco advertising such lawfully established advertising is considered a nonconforming sign and may remain in place subject to the regulations of 660-104.

660-103 Administration

660-103.A ZONING APPROVAL

Any person proposing to erect any sign must obtain a zoning permit. Applications for zoning permits must be accompanied by detailed plans, including scaled drawings of the proposed sign, a detailed site plan and other information deemed necessary by the zoning officer to determine compliance with applicable regulations.

660-104 Nonconforming Signs

660-104.A DESCRIPTION

A nonconforming sign is a sign that was lawfully established but that no longer complies with applicable zoning ordinance regulations because of the adoption or amendment of regulations after the sign was established.

660-104.B REGULATIONS

Nonconforming signs may continue subject to the following provisions:

- (1) Nonconforming signs must be maintained in good repair and safe condition.
- (2) Existing nonconforming signs may be changed in message or sign face, or changed, moved or replaced, provided that no new or increased nonconformity is created. This provision is not to be construed as allowing the illumination of previously non-illuminated nonconforming signs.
- (3) If a sign is nonconforming by reason of restrictions on its brightness or illumination or its use of strobe or beacon lights, the sign must be immediately removed or made to conform.
- (4) A temporary sign that is nonconforming by reason of restrictions on number, placement, or length of time

that such sign is allowed to remain in place must be immediately removed or made to conform.

- (5) A window sign that is nonconforming by reason of restrictions on its sign area must be immediately removed or made to conform.

660-104.C LOSS OF NONCONFORMING STATUS

If a nonconforming sign is removed from a building or lot, including the removal of a freestanding sign's structural supports, and not replaced within 24 months, the sign is presumed to be abandoned, unless the zoning hearing board determines, based on evidence provided by the subject property owner, that there was no intent to abandon the sign. Once a nonconforming sign is abandoned it may not be changed in message or sign face, or changed, moved or replaced unless such change, move or replacement brings the sign into compliance with all applicable regulations of this zoning ordinance.

[page intentionally blank]

ARTICLE 10. PROCEDURES

660-105 Common Provisions 10-2
660-106 Zoning Ordinance Text Amendments 10-4
660-107 Zoning Map Amendments 10-5
660-108 Curative Amendments 10-6
660-109 Zoning Permits 10-6
660-110 Special Exceptions 10-7
660-111 Variances 10-8
660-112 Reasonable Accommodation 10-10
660-113 Building Permits 10-10
660-114 Certificates of Occupancy 10-10
660-115 Certificates of Zoning Compliance 10-10
660-116 Appeals of Administrative Decisions 10-10

660-105 Common Provisions

660-105.A APPLICABILITY

The common provisions of this section apply to all of the procedures in this zoning ordinance unless otherwise expressly stated.

660-105.B MUNICIPALITIES PLANNING CODE

The review and approval procedures of this zoning ordinance are intended to comply with the provisions of the Pennsylvania Municipalities Planning Code. If any provision of this zoning ordinance is in conflict with any provision of the Municipalities Planning Code or if this zoning ordinance fails to incorporate a provision required for implementation of or consistency with the Pennsylvania Municipalities Planning Code, provisions of the Pennsylvania Municipalities Planning Code govern.

660-105.C REVIEW & DECISION-MAKING AUTHORITY

Table 660-15 provides a summary of review and decision-making authority under this zoning ordinance. If this summary table conflicts with the detailed, written procedures contained elsewhere in this zoning ordinance, the detailed, written procedures govern.

660-105.D APPLICATIONS AND FEES

- (1) **Applicability.** The application and fee provisions of this subsection apply to zoning applications filed by “eligible applicants.”
- (2) **Eligible Applicants.** When the procedures of this article allow an application to be filed by the "subject property owner," such applications must be signed by an equitable owner or one or more individuals who, either

individually or in combination, own at least 50% of the subject property. Proof of ownership is required.

- (3) **Form of Application.** Applications required under this zoning ordinance must be submitted in a form and in such numbers as required by the official responsible for accepting the application. Applications must include the names and addresses of all owners of record of the property that is the subject of the application as well as information needed for authorized review and decision-making bodies to determine compliance with all applicable regulations of this zoning ordinance. Such information includes maps, plats, surveys, dimensioned site plans, building elevations, landscape plans, engineering documents, environmental reports, traffic studies, and other information and data expressly required by this zoning ordinance or as determined to be necessary by the zoning officer or other authorized review or decision-making body for conducting a competent review of the application.
- (4) **Fees and Notification Costs**
 - (a) All applications filed by property owners must be accompanied by required zoning fees (see § 270-28 of the municipal code).
 - (b) Costs associated with retaining the services of a stenographer, when required, must be split evenly between the city and the applicant or appellate. Costs associated with obtaining copies of transcripts must be paid by the person or entity requesting the copies.

Table 660-15. Review & Decision-Making Summary

PROCEDURE	ZO	LVPC	HARB	ACPC	ZHB	CC
Zoning Ordinance Text Amendments	○	○		○	○	●
Zoning Map Amendments	○	○		○	○	●
Curative Amendments	○	○		○	◐	◐
Special Exceptions	○		◐	◐	●	
Zoning Permits	●					
Variances	○				●	
Appeals of Administrative Decisions					●	

Table notes: ○ = review & recommendation authority | ● = final decision-making authority | ◐ = authority varies
 ZO = zoning officer | ZHB = zoning hearing board | LVPC = Lehigh Valley planning commission
 HARB = historical architectural review board | ACPC = Allentown city planning commission | CC = city council

(5) Completeness, Accuracy and Sufficiency

- (a) An application will be considered complete and ready for processing only if it is submitted in the required number and form, includes all required information, and is accompanied by all required fees.
- (b) Officials responsible for accepting applications must make a determination of application completeness within 10 business days of the date than an application is filed.
- (c) If an application is determined to be incomplete, the official responsible for accepting the application must provide notice to the applicant along with an explanation of the application’s deficiencies. Notice of an incomplete application may be provided by personal service, electronic mail, or first-class mail.
- (d) No further processing of incomplete applications will occur, and incomplete applications will be pulled from the processing cycle. When the deficiencies are corrected, the application will be placed in the first available processing cycle. If the deficiencies are not corrected by the applicant within 90 days, the application will be deemed to have been withdrawn.
- (e) Applications deemed complete will be placed in the first available application processing cycle and will be reviewed by staff and other review and decision-making bodies, in accordance with the applicable review and approval procedures of this zoning ordinance.
- (f) The official responsible for accepting the application may require that applications or plans be revised before being placed on an agenda for possible action if the official determines that:
 - [1] The application or plan contains one or more significant inaccuracies or omissions that will hinder timely or competent evaluation of the plan’s/application’s compliance with zoning ordinance requirements or other regulations;
 - [2] The application contains multiple minor inaccuracies or omissions that hinder timely or competent evaluation of the plan’s or application’s compliance with zoning ordinance requirements or other regulations; or
 - [3] The decision-making body does not have legal authority to approve the application as filed.

660-105.E APPLICATION PROCESSING CYCLES

Officials responsible for accepting applications, after consulting with review and decision-making bodies, are

authorized to establish reasonable cycles and timelines for processing applications, including deadlines for receipt of complete applications.

660-105.F PUBLIC HEARINGS

- (1) **General.** The body conducting the hearing is authorized to establish reasonable rules and procedures governing the conduct of hearings and the presentation of information and comments.
- (2) **Continuances.** Once commenced, a public hearing may be continued by the hearing body. No re-notification is required if the continuance is set for specified date and time and that date and time is announced at the time of the continuance. If a public hearing is continued or postponed for an indefinite period of time from the date of the originally scheduled public hearing, new public hearing notice must be given before the rescheduled public hearing. If the applicant requests and is granted a continuance or postponement requiring re-notification, the body conducting the hearing is authorized to require that the applicant pay any costs of re-notification.

660-105.G PUBLIC HEARING NOTICES

Unless otherwise expressly stated in this zoning ordinance or the Municipalities Planning Code, public hearing notices must include:

- (1) The name of applicant or parties of interest;
- (2) Location and zoning classification of the property that is the subject of the public hearing;
- (3) The nature of the amendment, application, or request;
- (4) The place where the amendment, application, or request may be examined; and
- (5) The time and place of the public hearing.

660-105.H REVIEW AND DECISION-MAKING

- (1) **Authorized Actions.**
 - (a) Review and decision-making bodies may take any action that is consistent with:
 - [1] The regulations of this zoning ordinance and state law;
 - [2] Any rules or by-laws that apply to the review or decision-making body; and
 - [3] The notice that was given.
 - (b) Actions taken by review and decision-making bodies must be based on the same plans that have been reviewed by the zoning officer (rather than new or revised plans that have not been first reviewed by the zoning officer).
- (2) **Burden of Proof or Persuasion.** In all cases, the burden is on the applicant to show that an application or

proposal complies with all applicable review or approval criteria.

(3) Continuance or Deferral. Decision-making bodies are authorized to continue a public hearing or defer action on a matter in order to receive additional information or further deliberate.

(4) Conditions of Approval

- (a)** Review bodies are authorized to recommend conditions and decision-making bodies are authorized to approve the subject application with conditions.
- (b)** Any conditions recommended or approved must relate to a situation likely to be created or aggravated by the proposed use or development (e.g., buffers or visual screening) and must be roughly proportional to the impacts of the use or development.
- (c)** When conditions of approval are imposed, the decision-making body is authorized to require that applicant post a performance bond, escrow account, or other financial surety in order to guarantee compliance with applicable conditions.

660-106 Zoning Ordinance Text Amendments

660-106.A GENERAL

The city council is authorized to amend the text of this zoning ordinance in accordance with procedural requirements established in the Municipalities Planning Code.

660-106.B INITIATION

Zoning ordinance text amendments may be initiated by the city council on its own motion, by the Allentown city planning commission, or by petition of one or more citizens, subject to the procedures of this section.

660-106.C PUBLIC HEARING AND NOTICE

Before voting on the enactment of a proposed zoning ordinance text amendment, the city council must hold a public hearing on the proposed amendment. Notice of the city council's required public hearing must be provided in accordance with the Municipalities Planning Code.

660-106.D ALLENTOWN CITY PLANNING COMMISSION REVIEW

Proposed zoning ordinance text amendments must be submitted to the Allentown city planning commission and the Lehigh Valley Planning Commission for review and recommendation at least 30 days before the city council's public hearing on the proposed text amendment. Any recommendations stemming from these reviews should be submitted to the city council before the scheduled

public hearing on the matter. Failure of either the Allentown city planning commission or the Lehigh Valley Planning Commission to submit a report or recommendation is not cause to delay the required public hearing or city council action.

660-106.E HEARING AND FINAL ACTION

- (1)** The city council must hold a public hearing to consider the proposed text amendment and, following the close of the public hearing, act to:
 - (a)** Enact the proposed zoning ordinance text amendment;
 - (b)** Enact the proposed zoning ordinance text amendment with revisions (subject to the provisions of paragraph 2, below); or
 - (c)** Deny the proposed zoning ordinance text amendment.
- (2)** Before voting to enact a zoning ordinance text amendment that substantively modifies the text amendment considered at the original public hearing, the proposed text amendment must be resubmitted to the Allentown city planning commission and the Lehigh Valley Planning Commission for review and recommendation and another public hearing must be held by the city council. Notice of this subsequent public hearing must be provided in accordance with the Municipalities Planning Code.
- (3)** An affirmative vote of at least 4 members of the city council is required to enact a zoning ordinance text amendment.

660-106.F REVIEW AND APPROVAL CRITERIA

The decision to amend the zoning ordinance text is not controlled by any one criterion or standard. In making decisions about zoning ordinance text amendments, review and decision-making bodies must consider all relevant factors, including at least the following:

- (1)** Whether the proposed text amendment is in conformity with the comprehensive plan; and
- (2)** Whether the proposed zoning ordinance text amendment is necessary to respond to changes in demographic, economic, or development trends or to changes in community goals and objectives, emergence of new land uses, or changes to the Municipalities Planning Code or case law.

660-106.G POST-ENACTMENT

- (1)** Within 30 days after enactment of a zoning ordinance text amendment, a copy of the amendment must be forwarded to the Lehigh Valley Planning Commission.

Figure 660(31) Zoning Map Amendments

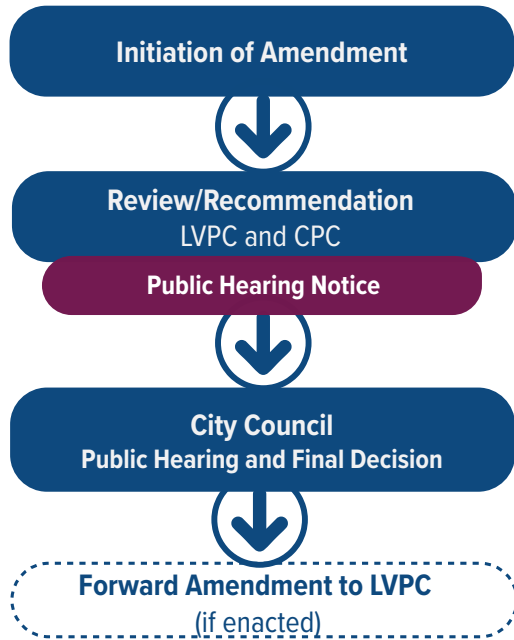

(2) If advertisement of the zoning ordinance text amendment is required by other laws or ordinances, a reference to the place where copies of the amendment may be obtained satisfies such requirements.

660-107 Zoning Map Amendments

660-107.A GENERAL

The city council is authorized to amend the zoning map in accordance with procedural requirements established in the Municipalities Planning Code.

660-107.B INITIATION

Zoning map amendments may be initiated by the city council on its own motion, by the Allentown city planning commission, or by petition of one or more citizens, subject to the procedures of this section.

660-107.C PUBLIC HEARING AND NOTICE

Before voting on the enactment of a proposed zoning map amendment, the city council must hold a public hearing on the proposed amendment. Notice of the city council's required public hearing must be provided in accordance with the Municipalities Planning Code.

660-107.D ALLENTOWN CITY PLANNING COMMISSION REVIEW

Proposed zoning map amendments must be submitted to the Allentown city planning commission and the Lehigh Valley Planning Commission for review and recommendation at least 30 days before the city council's public hearing

on the proposed text amendment. Any recommendations stemming from these reviews should be submitted to the city council before the scheduled public hearing on the matter. Failure of either the Allentown city planning commission or the Lehigh Valley Planning Commission to submit a report or recommendation is not cause to delay the required public hearing or city council action.

660-107.E HEARING AND FINAL ACTION

- (1) The city council must hold a public hearing to consider the proposed zoning map amendment and, following the close of the public hearing, act to:
 - (a) Enact the proposed zoning map amendment;
 - (b) Enact the proposed zoning map with modifications (subject to the provisions of paragraph 2, below); or
 - (c) Deny the proposed zoning map amendment.
- (2) Before voting to enact a zoning map amendment that includes land not included in the map amendment considered at the original public hearing or that proposes rezoning to a more permissive zoning classification than considered at the original public hearing, the proposed zoning map amendment must be resubmitted to the Allentown city planning commission and the Lehigh Valley Planning Commission for review and recommendation and another public hearing must be held by the city council. Notice of this subsequent public hearing must be provided in accordance with the Municipalities Planning Code.
- (3) An affirmative vote of at least 4 members of the city council is required to enact a zoning ordinance text amendment.

660-107.F REVIEW AND APPROVAL CRITERIA

The decision to amend the zoning map is a matter of legislative discretion that is not controlled by any one standard. In making recommendations and decisions about zoning map amendments, review and decision-making bodies must consider all relevant factors, including at least the following:

- (1) Whether the proposed zoning map amendment is in general conformity with the comprehensive plan;
- (2) Whether the proposed zoning map amendment is necessary to respond to changes in demographic, economic, or development trends or to changes in community goals and objectives, or changes to the Municipalities Planning Code or case law;
- (3) Whether the proposed zoning map amendment is generally consistent with the locational criteria established in the zone descriptions of Article 2; and

- (4) Whether the proposed zoning map will help promote land use and building patterns consistent with the surrounding area.

660-107.G POST-ENACTMENT

- (1) Within 30 days after enactment of a zoning map amendment, a copy of the amendment must be forwarded to the Lehigh Valley Planning Commission.
- (2) If advertisement of the zoning map amendment is required by other laws or ordinances, a reference to the place where copies of the amendment may be obtained satisfies such requirements.

660-108 Curative Amendments

660-108.A LANDOWNER CURATIVE AMENDMENTS

A landowners who wishes to challenge on substantive grounds the validity of the text of this zoning ordinance or the zoning map as applied to the use or development of land in which the subject landowner has an interest, is authorized to submit to a curative amendment to the city with a written request that the landowner’s challenge and proposed amendment be heard and decided by the zoning hearing board, as provided in Section 609.1 of the Municipalities Planning Code.

660-108.B MUNICIPAL CURATIVE AMENDMENTS

If the city council determines that the text of this zoning ordinance or the zoning map is substantially invalid as applied to one or more properties, it must take actions in accordance with Section 609.2 of Municipalities Planning Code.

660-109 Zoning Permits

660-109.A APPLICABILITY

A zoning permit is required from the zoning officer before any of the following:

- (1) The commencement of a new or expanded use of land or structure or the development of new or expanded outdoor storage or display, or parking or loading area.
- (2) The construction, expansion or placement of any structure or part thereof; and
- (3) The construction, extension or placement of any sign except those expressly exempt from permit requirements.

660-109.B ACCOMPANYING SITE PLAN

- (1) **Applicability.** A legible, certified plan drawn to scale, showing the proposed structures and uses in their exact location, in relation to lot and street lines must be submitted as part of a zoning permit application for all of the following unless the zoning officer determines a site

plan is not necessary to determine compliance with this zoning ordinance:

- (a) Any use or activity for site plan approval for which site plan approval is expressly required under this zoning ordinance;
- (b) Any use or activity that for which special exception approval is required under this zoning ordinance;
- (c) Any new principal nonresidential or mixed-use building or land use;
- (d) Any expansion of a nonresidential or mixed-use building resulting in the addition of more than 2,000 square feet of total floor area;
- (e) Any new or expanded parking area that includes 10 or more new parking spaces;
- (f) Any new residential building containing 3 or more dwelling units; and
- (g) Any project for which site plan review is determined to be necessary by the zoning officer.

- (2) **Relationship to SALDO.** The site plan requirements of this section are not intended to replace or conflict with the subdivision and land development ordinance (SALDO). In cases involving “land developments,” the review procedures contained in the SALDO govern.

660-109.C APPLICATION FILING

Zoning permit applications may be filed by the subject property owner, as defined in 660-105.D or by any tenant of the subject property with written permission of the property owner. Applications must be filed with the zoning officer.

660-109.D ACTION

A zoning permit may be issued only if the zoning officer determines that the use, development, or construction proposed complies with applicable requirements of this zoning ordinance, including any approved special exceptions or variances.

660-109.E PRELIMINARY OPINION

Applicants may submit a request for a preliminary opinion on whether a proposed use or development complies with this zoning ordinance in accordance with the Municipalities Planning Code.

660-109.F BUILDING PERMITS

Building permits must be secured from the building inspector before starting any construction, erection or alteration of any building, structure, street sign or billboard (see 660-113).

660-109.G EXPIRATION; LAPSE OF APPROVAL

- (1) **Zoning Permit Applications.** A zoning permit application expires 6 months after the filing of a complete application unless the zoning permit is issued

or the decision of the zoning hearing officer is appealed to the zoning hearing board.

- (2) **Approved Zoning Permits.** An approved zoning permit lapses and has no further effect unless:
 - (a) All required city permits are issued and work is actively initiated within 12 months of the date of issuance of the zoning permit; and
 - (b) All construction work is completed, the use is established, and all required inspections have been completed within 24 months of the date of issuance of the zoning permit.

660-110 Special Exceptions

660-110.A GENERAL

Special exception approval is required from the zoning hearing board whenever a requirement for such approval is expressly stated by the provisions of this zoning ordinance. Applications for special exception approval must be processed in accordance with the special exception procedures of this section.

660-110.B PREAPPLICATION ACTIVITIES

- (1) **General.** A special exception application may be filed only after:
 - (a) The zoning officer reviews the zoning permit application and determines that the use or activity proposed requires special exception approval under this zoning ordinance; and
 - (b) Any required preapplication review is complete.
- (2) **Preapplication Review**
 - (a) Whenever the regulations of this zoning ordinance expressly require that uses or activities requiring special exception approval be referred to a board, commission, or other review body for preapplication review, the zoning officer must refer the special exception proposal to such board, commission, or review body for review. The zoning officer is also authorized to refer a proposed special exception to a board, commission, or review body for review based on the location or nature of the proposed special exception use or activity.
 - (b) The general purpose of preapplication review by other boards, commissions, or bodies is to ensure review for compliance with applicable plans, regulations, policies, and guidelines and to provide timely background information for the zoning hearing board's consideration.
 - (c) Applicants proposing special exception uses or activities requiring preapplication review must submit to the zoning officer a written request to be

Figure 660(32) Special Exceptions

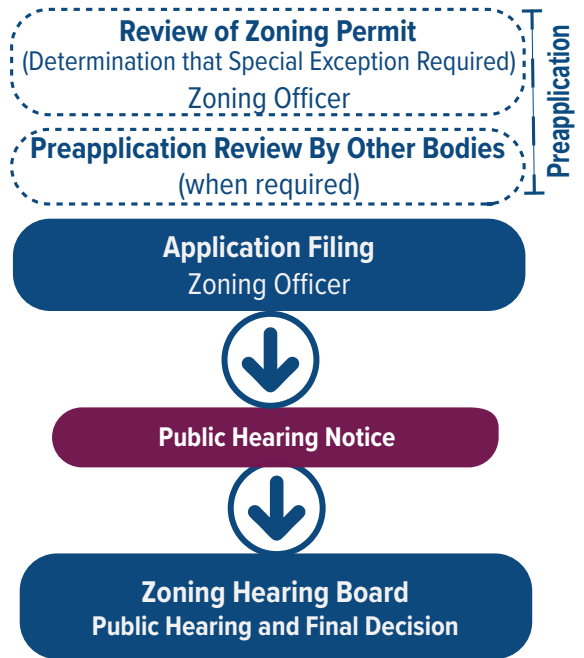

placed on the next available meeting agenda of the subject board, commission, or review body. The request must be received by the zoning officer at least 30 days in advance of the meeting.

- (d) Once the board, commission, or other review body has conducted its final preapplication review meeting on the proposed special exception, the applicant may submit the special exception application. In order for comments and recommendations to be considered by the zoning hearing board, the board, commission, or other review body must submit them in writing to the zoning officer within 45 days of the close of the final meeting at which the matter was considered.

660-110.C APPLICATION FILING

Once all required preapplication activities are complete, special exception applications may be filed by the subject property owner, as defined in 660-105.D or by any tenant of the subject property with written permission of the property owner. Applications must be filed within 30 days of completion of all required preapplication activities.

660-110.D NOTICE OF HEARING

Notice of the zoning hearing board's required public hearing on the special exception application must be provided in accordance with the Municipalities Planning Code.

660-110.E HEARING AND FINAL ACTION

- (1) The zoning hearing board must hold a public hearing on the special exception application and, following the close of the hearing, act to approve the special exception application, approve the special exception application with conditions or deny the special exception application. The zoning hearing board may not take action on the special exception application until the zoning officer has received preapplication review comments (when required) or until 45 days after the close of the final preapplication meeting at which the matter was considered.
- (2) In all cases, the public hearing before the zoning hearing board must be held within 60 days of receipt of a complete special exception application and a decision on the application must be entered within 45 days of the close of the hearing, unless the applicant agrees in writing to an extension of time.
- (3) Special exception applications may be approved by a simple majority vote of the zoning hearing board.

660-110.F REVIEW AND APPROVAL CRITERIA

- (1) **General.**
 - (a) In acting on requests for special exception approval, the zoning hearing board must consider:
 - [1] Whether the proposed special exception is in general conformity with the comprehensive plan; and
 - [2] Whether the proposed special exception will result in land use and development that is generally consistent with and not detrimental to the surrounding neighborhood area.
 - (b) The zoning hearing board may not approve a special exception application if it determines any one or more of the following:
 - [1] That the use would result in a significant traffic safety hazard;
 - [2] That the use would create a significant public health and/or safety hazard;
 - [3] That the use would cause substantial negative impacts upon an established residential neighborhood.
 - [4] That the application does not comply with applicable use-specific standards or other applicable regulations of this ordinance.
- (2) **Conditions of Approval.** In acting on any special exception application, the zoning hearing board is authorized to impose such reasonable conditions and

safeguards as it may deem necessary to implement the purpose of this zoning ordinance (see also 660-105.H).

660-110.G LAPSE OF APPROVAL

- (1) An approved special exception lapses and has no further effect unless:
 - (a) All required city permits are issued and work is actively initiated within 12 months of the date of approval by the zoning hearing board; and
 - (b) All construction work is completed, the use is established, and all required inspections have been completed within 24 months of the date of approval by the zoning hearing board.
- (2) The lapse of approval time-frames of this section may be extended by the zoning hearing board for good cause shown. Extension requests must be filed before the special exception expires. Extension requests must be processed in accordance with the special exception procedures of this section and include all fees, notices and public hearings required for new special exception requests.

660-110.H SUCCESSIVE APPLICATIONS

The zoning hearing board is authorized to decline to consider any application for the same or substantially the same special exception for 12 months from the date of denial of the previous special exception request by the zoning hearing board.

660-110.I MODIFICATIONS

Modifications to approved special exceptions must be processed as a new special exception application, including all requirements for fees, notices and public hearings, except the zoning officer is authorized to approve minor modifications, such as the following:

- (1) Any modifications expressly authorized by zoning hearing board at the time of special exception approval; and
- (2) The addition or relocation of customary accessory uses and structures.

660-110.J APPEALS

A party aggrieved by a decision of zoning hearing board may appeal such decision to court in accordance with the Municipalities Planning Code.

660-111 Variances

660-111.A GENERAL

The zoning hearing board is authorized to hear and decide requests for variances when it is alleged that the provisions of the zoning ordinance inflict unnecessary hardship upon the applicant.

660-111.B PROHIBITED VARIANCES

The zoning variance procedures of this section may not be used to:

- (1) Waive, modify or otherwise vary any of the review and approval procedures;
- (2) Waive, vary, modify or otherwise override a condition of approval or requirement imposed by another authorized decision-making body or the state or federal government; or
- (3) Waive, vary or modify provisions for which variances are expressly prohibited.

660-111.C APPLICATION FILING

A variance application may be filed only after the zoning officer denies a zoning permit for non-compliance with this zoning ordinance. Variance applications may be filed by the subject property owner, as defined in 660-105.D or by any tenant of the subject property with written permission of the property owner. Applications must be filed with the zoning officer.

660-111.D NOTICE OF HEARING

Notice of the zoning hearing board required public hearing on a variance application must be provided in accordance with the Municipalities Planning Code.

660-111.E HEARING AND FINAL ACTION

- (1) The public hearing before the zoning hearing board must be held within 60 days of receipt of a complete variance application and a decision on the application must be entered within 45 days of the close of the hearing, unless the applicant agrees in writing to an extension of time.
- (2) Variance applications may be approved by a simple majority vote of the zoning hearing board.

660-111.F REVIEW AND APPROVAL CRITERIA

- (1) **General.** In order to approve a variance application, the zoning hearing board must make all of the following findings:
 - (a) That there are unique physical circumstances or conditions, including irregularity, narrowness, or shallowness of lot size or shape, or exceptional topographical or other physical conditions peculiar to the particular property and that the unnecessary hardship is due to such conditions and not the circumstances or conditions generally created by the provisions of the zoning ordinance in the neighborhood or zone in which the property is located;
 - (b) That because of such physical circumstances or conditions, there is no possibility that the property

can be developed in strict conformity with the provisions of the zoning ordinance and that the authorization of a variance is therefore necessary to enable the reasonable use of the property;

- (c) That such unnecessary hardship has not been created by the applicant;
 - (d) That the variance, if authorized, will not alter the essential character of the neighborhood or zone in which the property is located, nor substantially or permanently impair the appropriate use or development of adjacent property, nor be detrimental to the public welfare; and
 - (e) That the variance, if authorized, will represent the minimum variance that will afford relief and will represent the least modification possible of the regulation at issue.
- (2) **Conditions of Approval.** In acting on any variance, the zoning hearing board is authorized to impose such reasonable conditions and safeguards as it may deem necessary to implement the purpose of this zoning ordinance (see also 660-105.H)

660-111.G LAPSE OF APPROVAL

- (1) An approved variance lapses and has no further effect unless:
 - (a) All required city permits are issued and work is actively initiated within 12 months of the date of approval by the zoning hearing board; and
 - (b) All construction work is completed, the use is established, and all required inspections have been completed within 24 months of the date of approval by the zoning hearing board.
- (2) The lapse of approval time-frames of this section may be extended by the zoning hearing board for good cause shown. Extension requests must be filed before the variance expires. Extension requests must be processed in accordance with the variance procedures of this section and include all fees, notices and public hearings required for new variance requests.

660-111.H SUCCESSIVE APPLICATIONS

The zoning hearing board is authorized to decline to consider any application for the same or substantially the same variance for 12 months from the date of denial of the previous variance request by the zoning hearing board.

660-111.I APPEALS

A party aggrieved by a decision of zoning hearing board may appeal such decision to court in accordance with the Municipalities Planning Code.

Figure 660(33) Variances



660-112 Reasonable Accommodation

660-112.A PURPOSE

The procedures of this section establish a process for considering requests to modify otherwise applicable regulations to ensure reasonable accommodation for persons with disabilities seeking equal access to housing under the Americans with Disabilities Act and the Federal Fair Housing Amendments Act. For the purposes of this ordinance, “reasonable accommodation” means providing an individual with a disability or developers of housing for individuals with a disability, flexibility in the application of zoning regulations (including the modification or waiver of certain requirements), when it is necessary to eliminate barriers to housing opportunities.

660-112.B APPLICATION FILING

- (1) Applications for reasonable accommodation must be filed with the zoning officer.
- (2) The application must include a detailed explanation of why the requested modification is reasonably necessary to make the specific housing available to a person with a disability, including information establishing that the applicant is disabled under applicable laws, as well as other information required by the zoning officer to make the required determinations. If the project for which the reasonable accommodation request is being made also requires an additional zoning approval, then the applicant must file the request concurrently with the application for such approval.

660-112.C REVIEW AND APPROVAL

Reasonable accommodation requests must be processed in accordance with the special exception procedures of 660-110. In acting on such requests, the zoning hearing board must determine whether the applicant has demonstrated

that the requested modification is necessary to provide a "reasonable accommodation" required by the Americans With Disabilities Act, the Federal Fair Housing Amendments Act, or applicable state law.

660-112.D TRANSFER

Approved requests for reasonable accommodation are granted to an individual and do not run with the land unless the zoning hearing board determines that the modification is physically integrated into the structure and cannot easily be removed or altered to comply with this zoning ordinance or the accommodation is likely to be used by another individual with a disability.

660-113 Building Permits

660-113.A APPLICABILITY

Building permits must be secured from the building inspector before starting any construction, erection or alteration of any building, structure, sign or billboard.

660-113.B ZONING PERMIT PREREQUISITE

Building permits may be issued by the building inspector only after a zoning permit is issued.

660-113.C DISPLAY

Building permits must be displayed, as required by the building code. Display of the building permit serves the purpose of the zoning permit.

660-114 Certificates of Occupancy

If a certificate of occupancy is required under another code or ordinance, and if the activity involves a new building or change in the type of use, the zoning officer must sign the certificate of occupancy before occupancy of the building or affected portion of the building. The zoning officer's signature is intended to show that such building or use complies with this zoning ordinance.

660-115 Certificates of Zoning Compliance

Upon request and payment of applicable fees, a certificate of zoning ordinance compliance may be issued by the zoning officer certifying that an existing building, structure or use complies with all applicable provisions of the zoning ordinance and/or decisions of the zoning hearing board.

660-116 Appeals of Administrative Decisions

660-116.A APPLICABILITY

The zoning hearing board is authorized to hear and decide appeals when it is alleged there has been an error in any order, requirement, decision or determination made by the zoning officer or other authorized administrative official in the administration and interpretation of this zoning ordinance

660-116 Appeals of Administrative Decisions

or those regulations specified in Section 909.1 of the Municipalities Planning Code.

660-116.B RIGHT TO APPEAL

Except as otherwise expressly stated in this zoning ordinance, appeals of administrative decisions may be filed by any person aggrieved by the administrative official's decision or action. The zoning hearing board is authorized to make determinations about whether individuals filing appeals are "aggrieved" by the decision or action.

660-116.C FILING OF APPEAL

Appeals of administrative decisions must be filed with the zoning officer within 30 days of the date of the decision or determination being appealed by filing a notice of appeal specifying the grounds for the appeal.

660-116.D EFFECT OF FILING

The filing of a complete notice of appeal from any other order, requirement, or decision stays all proceedings in furtherance of the action being appealed, unless the zoning officer or other official from whom the appeal has been taken certifies to the zoning hearing board (after the notice of appeal has been filed), that, for reasons stated in the official's certification, a stay would cause imminent peril to life or property. In that case, proceedings are stayed only upon issuance of a restraining order, which may be granted by the zoning hearing board or a court of record.

660-116.E TRANSMITTAL TO BOARD

Upon receipt of a complete notice of appeal, the zoning officer or administrative official whose decision is being appealed must transmit to the zoning hearing board all papers constituting the record upon which the action appealed is taken.

660-116.F NOTICE OF HEARING

Notice of the zoning hearing board's required public hearing on the appeal must be provided in accordance with the Municipalities Planning Code and include mailed notice to parties in interest at least 6 days before the date of the required public hearing.

660-116.G HEARING AND FINAL DECISION

- (1) The zoning hearing board must hold a public hearing to consider the appeal within 60 days of the date that the notice of appeal was filed.
- (2) Within 45 days of the close of the public hearing, the zoning hearing board must take action on the appeal. The board's decision must be supported by written findings of fact.
- (3) In exercising the appeal power, the zoning hearing board has all the powers of the administrative official from whom the appeal is taken. The zoning hearing

board may affirm or reverse, wholly or in part, or modify the decision being appealed. The concurring vote of at least a simple majority of the zoning hearing board is necessary to reverse an administrative decision.

- (4) In acting on the appeal, the zoning hearing board must grant to the administrative official's decision a presumption of correctness, placing the burden of persuasion of error on the appellant.

660-116.H GENERAL REVIEW CRITERION

An administrative decision may be reversed only if the zoning hearing board finds that the zoning officer or other administrative official erred.

660-116.I APPEALS

A party aggrieved by a decision of zoning hearing board may appeal such decision to court in accordance with the Municipalities Planning Code.

[page intentionally blank]

DRAFT

ARTICLE 11. ADMINISTRATION

660-117 Review and Decision-Making Bodies 11-2
660-118 Violations, Penalties, & Enforcement 11-3

660-117 Review and Decision-Making Bodies

660-117.A ZONING OFFICER

- (1) The zoning officer is responsible for administration and enforcement of this zoning ordinance.
- (2) The zoning officer must keep a record of all applications for permits and a record of all permits issued, with a notation of all special conditions imposed on such permits. All plans and documents filed in connection with any application must be made a part of the records of the zoning office.

660-117.B ZONING HEARING BOARD

- (1) **Establishment.** A zoning hearing board is hereby established. The board must consist of 3 members, all of whom are to be appointed by the mayor for a term of 3 years, with the advice and consent of city council. The present members of the zoning hearing board continue in office until their terms expire.
 - (a) The city council may remove any member of the zoning hearing board for just cause, after a public hearing. Vacancies are to be filled for the remainder of the unexpired term by appointment of the mayor, with the advice and consent of city council.
 - (b) The zoning hearing board must elect its own officers and formulate its own rules of procedure to carry out the board's responsibilities under this zoning ordinance.
- (2) **Meetings.** Meetings of the zoning hearing board are to be held at the call of the chairperson and at such other times as the board may determine. The chairperson or in their absence, the acting chairperson, is authorized to administer oaths and compel the attendance of witnesses. All hearings of the zoning hearing board must be open to the public. The board must keep minutes of its proceedings, showing the vote of each member upon each question, or if a member is absent or fails to vote, indicating such fact.
- (3) **Records.** The zoning hearing board must keep records of its examinations and other official actions. Every rule or regulation, every amendment or appeal thereof and every order, requirement, decision or determination of the zoning hearing board must immediately be filed in the zoning office and be a public record.
- (4) **Alternative Members.** Three alternative members of the zoning hearing board are to be appointed by the mayor for a term of 3 years, with the advice and consent of city council. Alternate members of the zoning hearing board are authorized to perform the duties of a regular member of, when it is found that regular members of the board cannot perform due to absence or disqualification

and a quorum is not reached, or as otherwise provided by the Municipalities Planning Code.

- (a) The chairperson of the zoning hearing board is authorized to designate as many of the 3 alternate members to sit on the board as may be needed to provide a quorum, or as is otherwise provided by the Municipalities Planning Code.
 - (b) Alternate members of the zoning hearing board must continue to serve on the board in all proceedings involving the matter or case for which the alternate was initially appointed until the board has made a final determination on the matter or case. Designation of an alternate member pursuant to this section must be made on a case-by-case basis in rotation according to declining seniority among the alternate members.
 - (c) The zoning hearing board is authorized to appoint any of its own members or an independent attorney to act as a hearing officer to conduct any hearing on the board's behalf. When a hearing officer has been appointed, parties may waive further action by the zoning hearing board as provided in section 908 of the Pennsylvania Municipalities Planning Code.
- (5) **Compensation.** Each regular and alternate member of the zoning hearing board will be compensated in the sum of \$35.00 for attendance at each officially convened hearing of the board, unless such compensation is revised by resolution of city council. Compensation must be paid monthly by the city, upon receipt of certificates from the secretary of the zoning hearing board setting forth the dates on which the board was in session, including the names of those members actually present at the times indicated in the secretary's certificates.
 - (6) **Jurisdiction.** The zoning hearing board has jurisdiction to hear and render decisions on all matters assigned to the board under this zoning ordinance, including the following:
 - (a) Substantive challenges (Landowner Curative Amendments) to the validity of the zoning ordinance, except those brought before the city council pursuant to sections 609.1 and 916.1(a)(2) of the Municipalities Planning Code.
 - (b) Challenges to the validity of the zoning ordinance raising procedural questions or alleged defects in the process of enactment or adoption. Such challenges must be brought by an appeal taken within 30 days after the effective date of the ordinance.

- (c) Appeals from the determination of the zoning officer, including but not limited to the granting or denial of any permit, or failure to act on the permit application, and the issuance of any cease and desist order.
- (d) Appeals from a determination by the city engineer, the building officer, or the floodplain manager in their administration and enforcement of the city's flood control regulations.
- (e) Applications for variances from the terms of this zoning ordinance or the flood control regulations.
- (f) Applications for special exceptions under this zoning ordinance or the flood control regulations pursuant to section 912.1 of the Municipalities Planning Code.
- (g) Applications for temporary use permits for buildings, structures, or uses that are deemed beneficial to the public health and necessary to the public welfare, provided that temporary use permits for construction and real estate offices may be issued by the zoning officer.
- (h) Appeals from a determination of the zoning officer or city engineer in the administration and enforcement of this zoning ordinance or land development regulations with reference to sedimentation and erosion control and storm water management insofar as the same relate to development applications not involving Article V or VII of the Municipalities Planning Code.

- (c) Discontinuance of any illegal work being done; or
- (d) Other action authorized by this zoning ordinance to ensure compliance with or prevent violation of the zoning ordinance's provisions.

660-118 Violations, Penalties, & Enforcement

660-118.A ENFORCEMENT AUTHORITY

The zoning officer is responsible for enforcing the provisions of this zoning ordinance.

660-118.B ACTIONS FOR COMPLIANCE

- (1) If any building, structure or land is, or is proposed to be, erected, constructed, reconstructed, altered, converted, maintained or used in violation of this zoning ordinance, the zoning officer, in addition to other remedies, may institute in the name of the city any appropriate action or proceeding to prevent, restrain, correct or abate such building, structure or land, or to prevent, in or about such premises, any act, conduct, business or use constituting a violation.
- (2) The zoning officer is expressly authorized to order:
 - (a) Discontinuance of any illegal use of land, buildings or structures;
 - (b) Removal of illegal buildings or structures or of illegal additions, alterations or structural changes;

660-118.C REVOCATION OF PERMITS

- (1) The zoning officer is authorized to cancel, revoke, withhold, or suspend a permit issued under the provisions of this zoning ordinance in the case of one or more of the following:
 - (a) A false statement or misrepresentation of facts was used to obtain the permit;
 - (b) The permit was issued in error;
 - (c) Any condition imposed by the zoning hearing board upon a special exception or variance is being violated; or
 - (d) Work is being carried out in violation of applicable provisions of this zoning ordinance or in violation of approved site plan or approved permit.
- (2) Written notice of revocation must be served upon the owner, the owner's agent or contractor, or upon any person employed on the building or structure for which such permit was issued. If no persons can reasonably be served with notice, the notice must be posted in a prominent location.
- (3) Appeals of revocation decisions may be taken to the zoning hearing board in accordance with the appeal procedures of 660-116.

660-118.D PENALTIES

- (1) Any person, partnership or corporation that violates the provisions of this zoning ordinance, or a prior city zoning ordinance then in effect, must, upon being found liable in a civil enforcement proceeding commenced by the city, pay a judgment of not more than \$500.00, plus all court costs, plus reasonable attorney fees incurred by the city.
- (2) Each day that a violation is continued constitutes a separate offense.

660-118.E NOTICE OF VIOLATIONS

Upon finding that any of the provisions of this zoning ordinance are being violated, the zoning officer must provide written notice to the person responsible for such violation. The written notice enforcement notice must meet the requirements of the Municipalities Planning Code and include the following:

- (1) The name of the owner of record and any other person against whom the municipality intends to take action.
- (2) The location of the property in violation.

- (3) The specific violation with a description of the requirements which have not been met, citing in each instance the applicable provisions of the ordinance.
- (4) The date before which the steps for compliance must be commenced and the date before which the steps must be completed.
- (5) That the recipient of the notice has the right to appeal to the zoning hearing board within a prescribed period of time in accordance with procedures set forth in the ordinance.
- (6) That failure to comply with the notice within the time specified, unless extended by appeal to the zoning hearing board, constitutes a violation, with possible sanctions clearly described.
- (7) In any appeal of an enforcement notice to the zoning hearing board, the municipality shall have the responsibility of presenting its evidence first.
- (8) Any filing fee paid by a party to appeal an enforcement notice to the zoning hearing board shall be returned to the appealing party by the municipality if the zoning hearing board or any court in a subsequent appeal rules in the appealing party's favor.

DRAFT

ARTICLE 12. NONCONFORMITIES

- 660-119 General 12-2
- 660-120 Nonconforming Lots 12-2
- 660-121 Nonconforming Uses 12-3
- 660-122 Nonconforming Buildings & Structures 12-4
- 660-123 Nonconforming Signs 12-4
- 660-124 Nonconforming Development Features 12-4

660-119 General

660-119.A APPLICABILITY

The regulations of this article govern nonconformities, which are lots, uses, buildings, signs, and other improvements that were lawfully established but—because of the adoption of new or amended regulations—no longer comply with one or more provisions of this zoning ordinance.

660-119.B PURPOSE

Occasionally, lots, uses, buildings, signs, and other improvements that were lawfully established (i.e., in compliance with all regulations in effect at the time of their establishment) are made nonconforming because of changes in the zoning regulations that apply to the subject property (e.g., through zoning map changes or amendments to the text of the zoning ordinance). The regulations of this article are intended to clarify the effect of this “nonconforming” status and avoid confusion with “illegal” uses and activities (i.e., those established in violation of applicable zoning regulations). The regulations of this article are also intended to:

- (1) Recognize the interests of landowners in continuing to use their property for uses and activities that were lawfully established;
- (2) Promote maintenance, reuse, and rehabilitation of existing buildings; and
- (3) Place reasonable limits on nonconformities that have the potential to adversely affect surrounding properties.

660-119.C GOVERNMENTAL ACTION

Any lot or building that is rendered nonconforming by the action of a governmental agency in opening, closing, widening, paving or improvement of any street or acquiring any right-of-way or any governmental condemnation, is, absent any other reason for nonconformity, exempt from the nonconformity regulations of this article and will, for all purposes of this ordinance, be considered to exist in the same condition as immediately before such governmental action.

660-119.D AUTHORITY TO CONTINUE

- (1) Any nonconformity that existed on the effective date specified in 660-01.C or any situation that becomes nonconforming upon adoption of any amendment to this zoning ordinance may be continued in accordance with the regulations of this article unless otherwise expressly stated.
- (2) Uses, lots and buildings that were not lawful when they were first established, or that changed in an unlawful manner, have no right to continue, and must be terminated or brought into conformance with all applicable provisions of this zoning ordinance.

660-119.E DETERMINATION OF STATUS

- (1) The burden of proving that a situation has nonconforming status rests with the subject property owner.
- (2) The zoning officer is authorized to determine whether adequate proof of nonconforming status has been provided by the subject property owner.
- (3) Appeals of the zoning officer’s decision on nonconforming status determinations may be appealed in accordance with the appeal procedures of 660-116.

660-119.F REPAIRS AND MAINTENANCE

- (1) Nonconformities must be maintained to be safe and in good repair.
- (2) Repairs and normal maintenance that do not increase the extent of nonconformity and that are necessary to keep a nonconformity in sound condition are permitted unless otherwise expressly prohibited by this zoning ordinance.
- (3) Nothing in this article is intended to prevent nonconformities from being structurally strengthened or restored to a safe condition in accordance with an order from a duly authorized city official.

660-119.G CHANGE OF TENANCY OR OWNERSHIP

Nonconforming status runs with the land and is not affected merely by change of ownership or possession or by right of possession of property.

660-120 Nonconforming Lots

660-120.A DESCRIPTION

A nonconforming lot is a lawfully created lot that does not comply with currently applicable minimum lot area or minimum lot width regulations of the zone in which the lot is located.

660-120.B USE OF NONCONFORMING LOTS

- (1) Except as expressly stated in paragraph 2 of this subsection (below), a single nonconforming lot may be used in accordance with the use regulations of the subject zone, and buildings may be erected on such a nonconforming lot, subject to compliance with all other applicable regulations of this zoning ordinance.
- (2) If 2 nonconforming lots are contiguous and under common ownership, and at least one of the lots does not include a principal building, then the 2 lots will be considered to be merged, and may not be separately sold or separately developed or built upon.

660-121 Nonconforming Uses

660-121.A DESCRIPTION

A nonconforming use is a land use that was lawfully established in accordance with use regulations in effect at the time of its establishment but that is no longer allowed by the use regulations of the zone in which the use is now located. Nonconforming uses expressly include the following:

- (1) Lawfully established uses that are not allowed in the zone in which they are located;
- (2) Lawfully established uses that do not comply with supplemental use (use-specific) regulations that apply to the subject use type; and
- (3) Lawfully established uses that do not comply with applicable regulations governing the allowed number and location of dwelling units within the subject building type.

660-121.B CHANGE OF USE

- (1) **Authorization by Zoning Officer.** The zoning officer is authorized to issue a permit for a change from one nonconforming use to another nonconforming use, provided that all of the following conditions are met:
 - (a) The same general type of use is involved (such as from one retail use to another retail use, or from one personal service use to another personal service use);
 - (b) The operator of the new use agrees in writing as a condition of the permit to abide by any applicable conditions that were established for the previous use of the property;
 - (c) The new use involves similar or less intensive characteristics compared to the previous use, such as hours and manner of operation, types of merchandise or service, and waste generation; and
 - (d) The new use does not involve the sale of alcohol unless the previous use also involved the sale of alcohol in a similar manner.
- (2) **Authorization by Zoning Hearing Board.** The zoning hearing board is authorized to approve a special exception allowing a nonconforming use to be changed to another nonconforming use upon determining that the proposed new use will be no more detrimental to its neighborhood and surroundings than the use it is to replace. In making such determination, the zoning hearing board may consider the following factors, among others: traffic generated; traffic safety; nuisance characteristics, such as emission of noise, dust, odors and smoke; creation of vibrations and fire hazards; waste generation; storage characteristics; public health

and safety hazards; and the hours and manner of operation.

- (3) **Hours of Operation.** Notwithstanding any provisions to the contrary, special exception approval from the zoning hearing board is required if a proposed change of a nonconforming use is proposed to be open to the public during the hours between midnight and 6 a.m. in an MX-C or GX-C zone or between 10 p.m. and 6 a.m. in any MX-N, GX-N, or N zone. In considering such proposed special exception, the zoning hearing board must consider whether the late night hours are likely to create nuisances and incompatibilities with nearby residential uses, considering the type of proposed use and its location. In considering the special exception approval, the zoning hearing board may further restrict the hours of operation beyond the limits stated herein.

660-121.C EXPANSION OF USE

- (1) **General.** A nonconforming use and a building occupied by a nonconforming use may be expanded, only if the following conditions are met:
 - (a) Special exception approval is required for expansion of a nonconforming use.
 - (b) The total building floor area or total land area occupied by the nonconforming use, whichever is more restrictive, may not be increased by greater than 50% beyond the area that existed at the time the use first became nonconforming.
 - [1] The 50% maximum is measured in aggregate over the entire life of the nonconformity. For example, if a use became nonconforming in 1971, and was expanded by 20% in 1980, then only a cumulative 30% expansion is permitted after 1980.
 - [2] These provisions apply regardless of whether the use is expanding within an existing building or an addition to an existing building.
 - (c) Any expansion of a nonconforming use must meet all required setbacks and all other requirements of this zoning ordinance. No new nonconformity may be created.

(2) Nonconforming Junkyard or Scrapyard.

Notwithstanding any provision to the contrary, a nonconforming junkyard or scrapyard may not be expanded to occupy additional land area.

660-121.D REMODELING AND IMPROVEMENTS

A building in which a nonconforming use is located may be remodeled or otherwise improved as long as the remodeling or improvements do not violate other applicable regulations of this zoning ordinance.

660-121.E MOVEMENT

A nonconforming use may be moved in whole or in part to another location on the same lot only if the movement or relocation does not create additional or new nonconformities.

660-121.F LOSS OF NONCONFORMING STATUS

If the area occupied by a nonconforming use becomes unoccupied or unused and remains unoccupied or is not used by the nonconforming use during any continuous period of 12 months or more, the use is presumed to be abandoned, unless the zoning hearing board determines, based on evidence provided by the subject property owner, that the use was not abandoned. Once abandoned, such property or building may only be occupied by a use that conforms to this ordinance. This 12-month period is extended to 24 months for a lawful commercial nonconforming use in an N zone.

660-122 Nonconforming Buildings & Structures

660-122.A DESCRIPTION

- (1) **Nonconforming Building.** A nonconforming building is any building that was lawfully established but no longer complies with applicable building siting, parking & accessory structure, height, roof, or facade regulations of Article 3 or applicable building design regulations of Article 6.
- (2) **Nonconforming Structure.** A nonconforming structure is any structure, other than a building or a sign, that was lawfully established but no longer complies with applicable structure siting or height regulations.

660-122.B GENERAL

Nonconforming buildings and structures may remain, subject to the regulations of this section.

660-122.C ALTERATIONS AND EXPANSIONS

- (1) **General.** Unless otherwise expressly stated in the nonconforming building and structure regulations of this section, alterations of nonconforming buildings and structures, including enlargements and expansions, are allowed only if the altered portion of the building or structure complies with applicable regulations and does not increase the extent of the existing nonconformity.
- (2) **Side Setbacks for House, Townhouse and Rowhouse Buildings.** If an existing house building type, twinhouse building type, or rowhouse building type has a lawfully nonconforming side setback, additions may occur as of right to increase the building height or to extend other portions of the building into the nonconforming side setback, provided that:

- (a) The building may not be extended beyond the building's existing side setback;
- (b) No additional nonconformity may be created unless otherwise expressly stated herein;
- (c) All other requirements of this zoning ordinance must be met; and
- (d) An absolute minimum side setback of 3 feet must be maintained for any addition.

660-122.D USE

A nonconforming building may be used for any use allowed in the zone in which the building is located.

660-122.E MOVEMENT

A nonconforming building or structure may be moved to another location on the lot only if the movement or relocation eliminates or reduces the extent of nonconformity.

660-122.F RE-ESTABLISHMENT

- (1) A nonconforming building or structure that is destroyed or damaged by fire or other casualty or by act of God may be rebuilt or restored in a nonconforming manner only if the majority of the exterior walls are still structurally sound, except that a destroyed or damaged nonconforming house building type, twinhouse building type, or rowhouse building type may be reconstructed regardless of the amount of destruction provided that no new nonconformity is created or increased by the reconstruction.
- (2) When a nonconforming building or structure is permitted to be rebuilt or restored in a nonconforming manner, such permission may only be granted if all of the following conditions are met:
 - (a) The building or structure is properly secured after the damage or destruction;
 - (b) Work begins within 18 months after the date of damage or destruction, unless the zoning hearing board grants a time extension for good cause; and
 - (c) Work is diligently pursued to completion.

660-123 Nonconforming Signs

See the nonconforming sign regulations of 660-104.

660-124 Nonconforming Development Features

660-124.A DESCRIPTION

A nonconforming development feature is any aspect of a development—other than a nonconforming lot, nonconforming use, nonconforming building, or nonconforming sign—that was lawfully established, in accordance with zoning regulations in effect at the time of

660-124 Nonconforming Development Features

its establishment but that no longer complies with one or more regulations of this zoning ordinance. One common example is a site that does not comply with current parking, landscaping, screening requirements.

660-124.B GENERAL

Nonconforming development features must be brought into compliance with applicable zoning ordinance regulations when development or construction triggering compliance occurs. In other cases nonconforming development features may remain, but the nature and extent of such nonconforming development features may not be increased.

[page intentionally blank]

ARTICLE 13. MEASUREMENTS & DEFINITIONS

660-125 Language and Interpretation 13-2
660-126 Measurements 13-2
660-127 Terms Beginning with "A" 13-10
660-128 Terms Beginning with "B" 13-11
660-129 Terms Beginning with "C" 13-11
660-130 Terms Beginning with "D" 13-11
660-131 Terms Beginning with "E" 13-12
660-132 Terms Beginning with "F" 13-12
660-133 Terms Beginning with "G" 13-13
660-134 Terms Beginning with "H" 13-13
660-135 Terms Beginning with "I" 13-14
660-136 Terms Beginning with "J" 13-14
660-137 Terms Beginning with "K" 13-14
660-138 Terms Beginning with "L" 13-14
660-139 Terms Beginning with "M" 13-14
660-140 Terms Beginning with "N" 13-14
660-141 Terms Beginning with "O" 13-15
660-142 Terms Beginning with "P" 13-15
660-143 Terms Beginning with "Q" 13-15
660-144 Terms Beginning with "R" 13-15
660-145 Terms Beginning with "S" 13-16
660-146 Terms Beginning with "T" 13-17
660-147 Terms Beginning with "U" 13-17
660-148 Terms Beginning with "V" 13-17
660-149 Terms Beginning with "W" 13-17
660-150 Terms Beginning with "X" 13-17
660-151 Terms Beginning with "Y" 13-18
660-152 Terms Beginning with "Z" 13-18

660-125 Language and Interpretation

660-125.A MEANINGS AND INTENT

- (1) Words and terms expressly defined in this zoning ordinance, including those defined in Article 13, have the specific meanings assigned unless the context indicates another meaning.
- (2) Words that are not expressly defined in this zoning ordinance have the meaning assigned in Merriam-Webster’s Collegiate Dictionary.

660-125.B CONJUNCTIONS

Unless the context otherwise expressly indicates, conjunctions have the following meanings:

- (1) “And” indicates that all connected items or provisions apply; and
- (2) “Or” indicates that the connected items or provisions may apply singularly or in combination.

660-125.C COMPUTATION OF TIME

- (1) All references to “days” are to calendar days unless otherwise expressly stated. Any references to “business days” are references to regular city government working days, excluding Saturdays, Sundays and holidays observed by city government.
- (2) The time in which an act is to be completed is computed by excluding the first day and including the last day. If the last day is a Saturday, Sunday or holiday observed by city government, that day is excluded.
- (3) A day concludes at the close of business and any materials received by the city after that time will be considered to have been received the following day.

660-125.D TENSES AND USAGE

- (1) Words used in the singular include the plural. The reverse is also true.
- (2) Words used in the present tense include the future tense. The reverse is also true.
- (3) The words “shall,” “will,” and “must” are mandatory.
- (4) The phrase "may not" means that the subject act is prohibited.

660-125.E LISTS AND EXAMPLES

Unless otherwise expressly indicated, lists of items or examples that use “including,” “such as,” or similar terms are intended to provide examples only. They are not to be construed as exhaustive lists of all possibilities.

660-125.F USE DEFINITIONS

See Article 4 for an explanation of the use categorization system used in this zoning ordinance and for use type definitions.

660-125.G MEASUREMENT-RELATED TERMS

See 660-126.

660-125.H ABBREVIATIONS

Certain terms are sometimes abbreviated in this zoning ordinance. Abbreviations have the meanings assigned in Table 660-16.

Table 660-16. Abbreviations

ABBREVIATION	MEANING
ACPC	City Planning Commission
BFE	Base Flood Elevation
Ft.	Feet
GFA	Gross Floor Area
In.	Inches
LVPC	Lehigh Valley Planning Commission
Max.	Maximum
MPC	Municipalities Planning Code
MPD	Master Plan Development
Min.	Minimum
ROW or r.o.w.	Right-of-way
Sq. Ft.	Square Feet
ZHB	Zoning Hearing Board

660-125.I VERSIONS AND CITATIONS

All references in this zoning ordinance to other city, state or federal regulations are to be construed as referring to the most up-to-date version of those regulations or successor regulations, unless otherwise expressly indicated. When the referenced regulations have been repealed and not replaced by other successor regulations, zoning ordinance requirements for compliance are no longer in effect.

660-125.J PUBLIC OFFICIALS AND AGENCIES

References in this zoning ordinance to city officials, agencies, and staff are references to those of the City of Allentown.

660-126 Measurements

660-126.A FRACTIONS AND ROUNDING GENERALLY

When calculations required under this zoning ordinance result in fractions, any fractional result of less than one-half of the unit of the regulation is rounded down to the whole number and any fractional result of one-half or more of the regulation unit is rounded up to the whole number. For example, if the maximum regulation is 2 feet, a measurement of 1.5 feet (or 1-foot, 6 inches) is rounded up to 2 feet and a measurement of 1.25 feet (or 1-foot, 3 inches) is rounded

down to 1 foot. If the maximum regulation is in inches, fractions are rounded to the nearest inch.

660-126.B GENERALLY PARALLEL & PERPENDICULAR

"Generally parallel," when stated related to lot lines or building facades, means less than 45 degrees off the lot line or facade. "Generally perpendicular," when stated related to lot lines or building facades, means more than 45 degrees off the lot line or facade in any direction.

660-126.C LOT WIDTH

Lot width is the horizontal distance measured along the minimum front setback line between the side lot lines of a lot. If no minimum front setback is required, lot width is measured along the front lot line.

660-126.D LOT AREA

Lot area is measured as the total ground-level surface area contained within the lot lines of a lot.

660-126.E LOT FRONTAGE

The front lot line of the subject lot must be located along one of the street types designated.

660-126.F FRONT STREETWALL

(1) **Definition of Streetwall.** The minimum or maximum amount of building facade required along and generally parallel to a front street frontage and built within the build-to zone. See 660-12.J for determining front and side streets (if any) on the lot. Each building type regulates the streetwall as either a minimum percentage or a maximum building width as follows:

- (a) **Measurement: Minimum Percentage of Streetwall.** The percentage of front streetwall is calculated as the width of the principal structures, as measured within the front build-to zone, divided by the length of the lot line parallel to the front street, minus the minimum side setbacks or minimum side-street build-to zone setback. See Figure 660(34).
- (b) **Measurement: Maximum Streetwall.** The maximum streetwall is the measurement along all front facades that are generally parallel and facing the lot line, measured from the edge of the facade horizontally to the opposite edge of the facade, intended to limit the width of the building facade along the street.
- (2) **Height.** The streetwall or building facade being measured must meet the minimum height required for the building type. See 660-126.M.(2).
- (3) **Courtyard and Other Allowances.** Courtyards and other allowances may be listed in the building type regulations as exceptions or allowances.

- (a) **Minimum Percentage of Streetwall.** The length of the courtyard opening or expanded build-to zone may be counted towards percentage of front streetwall where defined in the supplemental regulations for the building type.
- (b) **Maximum Streetwall.** In cases related to a maximum building width, the courtyard is allowed and does not contribute to the maximum width as written.

660-126.G SETBACKS & BUILD-TO ZONES

The following applies to required setbacks and build-to zones. See Article 3 for the building type regulations.

- (1) **Measurement: Buildings.** Required setbacks and build-to zones are measured from the applicable lot line or specific location referred to in the regulation, to the exterior building walls generally parallel to the subject line.

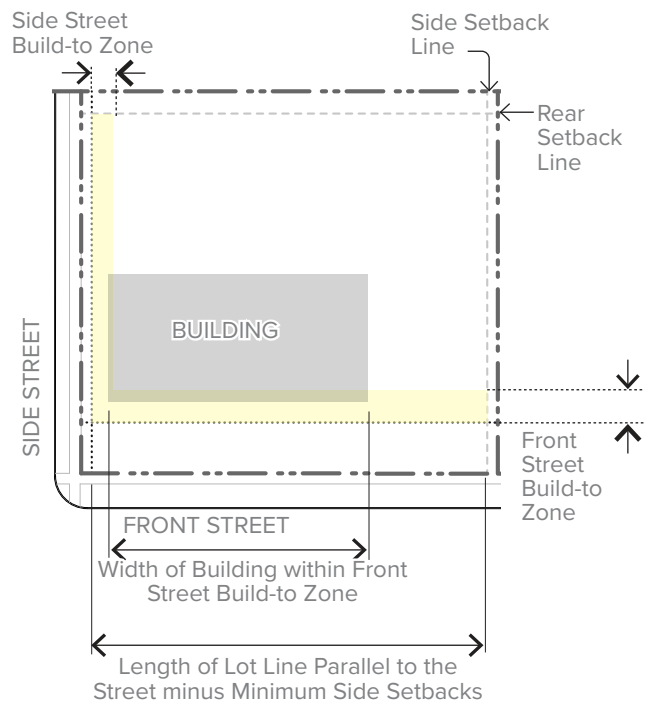

$$\frac{\text{Width of Building within Build-to Zone}}{\text{Length Front Lot Line Minus Minimum Side Setbacks}} = \text{Streetwall \%}$$

Figure 660(34) Measuring Front Streetwall

(a) Front and Side-Street Build-to Zones and Setbacks. Street (front and side-street) setbacks build-to zones are measured from the lot line abutting the edge of the street right-of-way into the lot. Build-to zones include both a minimum setback and maximum setback that the facade of the building must be located within.

- [1] C street frontages are typically not considered street frontages when they are located at the rear of the parcel, parallel to the front lot line. See 660-12.J, for explanation of frontages.
- [2] See 660-12.L for regulations requiring a minimum streetscape area. Where the minimum area does not exist, the build-to zone is measured from the edge of the expanded streetscape area into the lot.

- (b) Interior-Side Setbacks.** Side or interior-side setbacks are measured from the nearest side lot line that does not abut a street.
- (c) Rear Setbacks.** Rear setbacks are measured from the rear lot line.
- (d) Corner Lots.** On corner lots, the required front or side-street setback must be provided for each street frontage, depending on whether the abutting street is a front or side street. The lot line opposite of the front street is the rear lot line, requiring a rear setback. The lot line generally perpendicular to

the front street is the side lot line, requiring a side setback.

(e) Double-Frontage Lots. On double-frontage lots, the required front or side-street setback must be provided for each street frontage, depending on whether the abutting street is a front or side street. Generally applicable regulations apply per 660-12.J and supplemental building regulations for the building type may have additional requirements.

- (2) Exceptions to Build-to Zones.** Upper-story recessed balcony facades are not required to be located within the build-to zone.
- (3) Allowed Encroachments.** Allowed encroachments into setbacks or beyond build-to zones are as follows, unless otherwise established in the building type regulations:

(a) Minor Building Projections in All Yards for All Building Types. Roof overhangs, eaves, chimneys, bays, and other architectural features, such as cornices, may encroach up to 1.5 feet into any yard no closer than 1 foot from the lot line.

(b) Porches in Front Yards. Porches, stoops, decks, awnings encroaching into setbacks or beyond build-to zones into street yards are regulated in the building siting and supplemental regulations section for each building type. See Article 3.

(c) Steps and Ramps in Front Yards. Steps and ramps in front yards may encroach fully into any street yard up to within 1 foot of any lot line.

(d) Porches, Stoops, Decks in Rear and Side Yards. Open (unenclosed) or screened porches, stoops, awnings, decks, ramps, and steps may encroach into the side or rear yard up to within 1 foot of any lot line.

- (4) Setbacks on Irregular Lots.** Setbacks are measured from lot lines towards the center of the lot as follows:
 - (a)** When lot lines are curvilinear, setbacks must be measured parallel to the curvilinear lot line.
 - (b)** When there are multiple rear lot lines, the rear setback must be measured from each of the rear lot lines.

(5) Front-yard averaging. The average yard depth of buildings on adjacent lots is used to determine the applicable contextual setback for the subject lot, as follows:

(a) The build-to zone or averaged front yard depth is determined by calculating the mean yard depth that exists on the nearest 2 lots on either side of the subject lot.

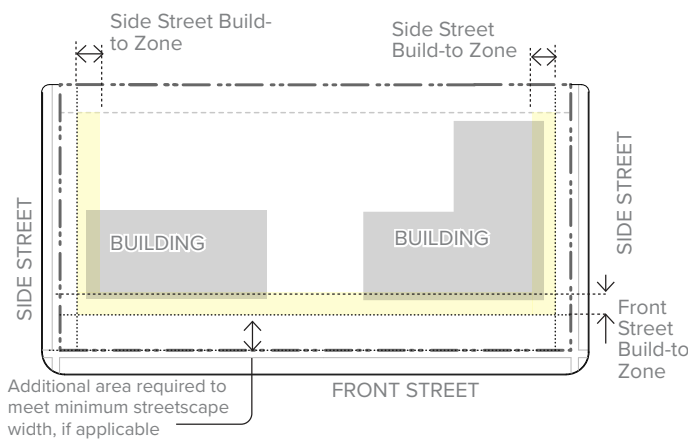

Figure 660(35) Build-to Zones

- (b) If one or more of the lots required to be included in the front-yard averaging calculation are vacant, the vacant lot will be deemed to have a street yard depth equal to the minimum street setback requirement of the subject zoning district.
 - (c) Lots with frontage on a different street than the subject lot or that are separated from the subject lot by a street or improved alley are not used in computing the front-yard average.
 - (d) When the subject lot is a corner lot, the mean street yard depth will be computed on the basis of the nearest 2 lots with frontage on the same street as the subject lot, unless those 2 lots are in a different zone. If the 2 abutting lots are in a different zone, front-yard averaging does not apply and the setback or build-to zone required in the regulation applies.
 - (e) When the subject lot abuts a corner lot with frontage on the same street, the mean yard depth will be computed on the basis of the abutting corner lot and the nearest 2 lots with frontage on the same street as the subject lot.
 - (f) If the surrounding parcels are vacant, the required minimum setback or build-to line/zone in the ordinance applies.
- (6) Waterway Frontage.** A river or trail frontage build-to zone or setback is measured from any required waterfront buffer into the lot perpendicular to the easement or lot line. See [350-14](#) for waterway buffer.
- (7) Measurement: Elements Other than Buildings.** Minimum setbacks that apply to elements other than buildings (e.g. parking areas, fences, storage areas) are

measured from the lot line, right-of-way line, or specific location referred to in the applicable regulations, to the nearest point of the feature.

660-126.H SEPARATION DISTANCE

Required minimum separation distances are measured in a straight line from lot line to lot line unless otherwise expressly stated.

660-126.I BUILDING COVERAGE

Building coverage is measured as the percentage of a lot covered by all buildings.

- (1) Green Roofs.** Green, or vegetated, roofs reduce the building's building coverage, by calculating the surface of the building's green roof at a factor of .75 or 75% of the area. For example, if the surface of the green roof measures 13,000 sq. ft., then 9,750 sq. ft. (75% of 13,000) contributes to the lot's maximum building coverage.
- (2) Outdoor Storage.** Outdoor Storage areas must be included in the building coverage calculation per [660-45](#).

660-126.J ATTACHED GARAGE AND DOOR LOCATION

(1) Garage Setback Measurement. Garage setbacks are defined in the building types (see [Article 3](#)) per one of the following:

- (a) Dimensional Setback.** When the building type regulation includes a dimensional setback for an attached garage, the attached garage setback is measured from the front facade of the building, located generally parallel and facing the lot front line. The setback is intended to promote the use of the area directly behind the front facade of any building for people and not the parking of vehicles.

(b) No Closer to Lot Line Than Front Facade. When no dimensional setback for an attached garage is included in the building type regulation, the garage facade facing a front lot line must be located farther from the lot line than the front facade.

(2) Garage Door Location. Any garage door must be located on one of the designated facades of the building.

660-126.K LIMITED SIDE-YARD PARKING

Where allowed, limited side-yard parking is located in the interior side yard and must be configured as one double- or single-loaded aisle of parking with the centerline of the aisle located perpendicular to the street. Limited side-yard parking may not extend into the front yard.

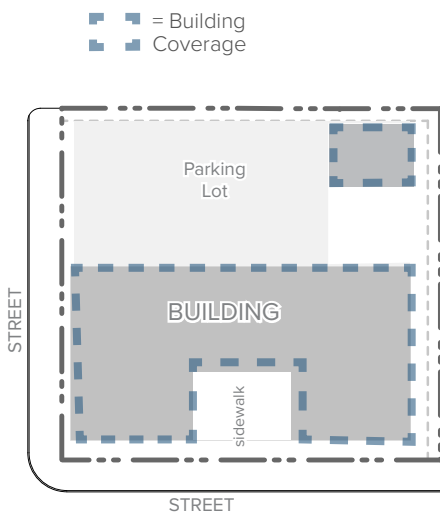

Figure 660(36) Building Coverage

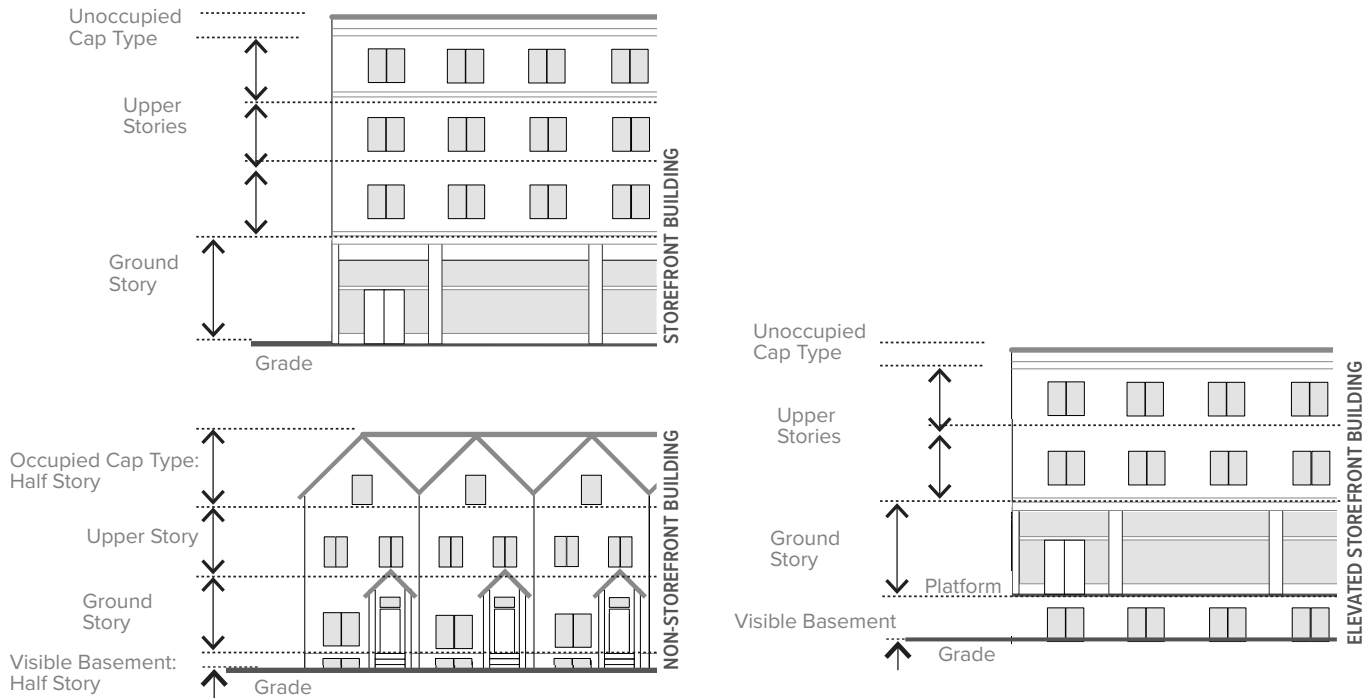

Figure 660(37) Measuring Building Height



Figure 660(38) Measuring Height along Sloped Street

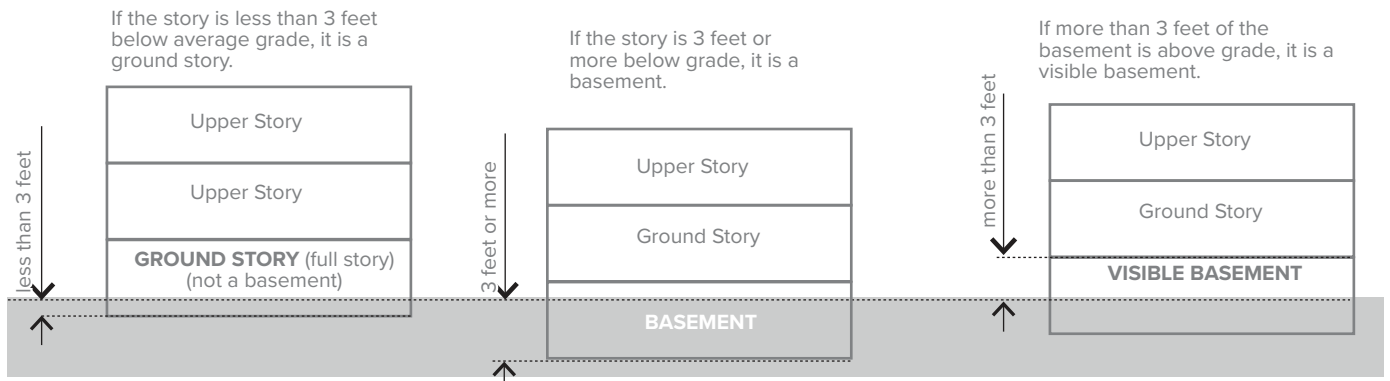

Figure 660(39) Basements & Visible Basements

660-126.L NUMBER OF DWELLING UNITS

The number of dwelling units allowed must be consistent with the subject building type standards.

(1) Number of Dwelling Units Allowed per Facade Width.

For certain building types, the requirement may be stated as X dwelling units allowed per every X feet of front facade width. The "every" means if increments of X feet are measured on the facade, and there is an increment left over that is less than X feet, that increment is not allowed to be utilized to determine the number of the dwelling units. For example, if the requirement is 3 units per every 18 feet of front facade width, a building with a front facade between 36 and 53 feet wide would allow up to 6 dwelling units. A building width of at least 54 feet wide would allow 9 dwelling units.

(2) Maximum Number of Dwelling Units. The maximum of number of dwelling units may not be exceeded, except as explicitly allowed per this ordinance.

660-126.M BUILDING HEIGHT

See [Figure 660\(37\)](#).

(1) Ground-Story Elevation. The ground-story elevation, located in the facade regulations for each building type, is measured from the average finished grade at the base of the building along any street lot line. A range is allowed per building type. See [Figure 660\(39\)](#) for basements and visible basements ranges above grade.

(2) Minimum Height. Each building type requires a minimum number of stories. The building must meet the minimum required height along all front street facades for a depth of at least 30 feet into the building. All building facades located within the build-to zone must meet the required minimum building height.

(3) Maximum Height. Maximum heights are specified in number of stories. This requirement applies to the entire building. The maximum number of stories may not be exceeded due to sloped sites. Heights must step with the grade in order to not exceed the maximum allowable height. See [Figure 660\(38\)](#).

(4) Towers. When expressly allowed in the building type tables, towers may exceed the overall maximum height of the subject building type (see [660-56](#)).

(5) Floor Area Ratio (FAR). FAR is the measurement of a building's floor area in relation to the size of the lot that the building is located on. FAR is measured by dividing the total gross building area (all stories) by the total area of the lot (building area (all stories) ÷ lot area).

(6) Height to Eaves. Eave height is measured from the floor elevation of the first floor to the eave.

(7) Roof Type. Roof types per [660-55](#) allowed by building type regulations (see [Article 3](#)) add additional height to the building.

(8) Half Stories. Half stories are stories either located fully within the roof type or in a visible basement.

(a) Roof. Where occupied building space is allowed within the roof type (see [660-55](#)), any space within the roof and within the floor to floor height counts as a half story towards the overall allowable height.

(b) Visible Basement. See [Figure 660\(39\)](#) for diagram and explanation of a visible basement and [660-128](#) for definitions of basements and visible basements.

(c) Two Half Stories. If a building has both a half story within the roof and a half story that is a visible basement, the combined height of the two half stories is considered one full story in terms of measuring overall height.

(9) Basements. See [Figure 660\(39\)](#) for illustration of basements and [660-128](#) for definitions of basements and visible basements.

(a) A basement that is not a visible basement does not count towards the minimum or maximum height of a building.

(b) Any building may have a basement, unless expressly prohibited in this ordinance.

(c) A basement may contain any use allowed within the building, including those allowed only in upper stories.

(10) Story Height. Each story is measured with a range of permitted floor-to-floor heights per the subject building type. See [Figure 660\(37\)](#).

(a) Measurement. All story heights are measured in feet between the floor of a story to the floor of the story above it, not including stairwells and other vertical circulation.

(b) Ground Story. When noted as a separate story height, the ground-story height must extend from the front street facade into the building a minimum of 30 feet. The remainder of the ground-story may meet either the defined ground-story heights or the height range permitted for all stories.

(c) Single-Story Buildings and Top-Story Measurement. For single-story buildings and the uppermost story of a multi-story building, the floor-to-floor height is measured from the floor of the story to the ceiling, unless a specific height is provided for a single-story building.

- (d) **Taller Spaces.** Taller spaces including mezzanines, atriums, and multi-story lobbies, are allowed within the interior of any building as follows:
- [1] **Front Facade.** Taller spaces may be located along up to 35% of the front facade, measured along the horizontal length of each story.
 - [2] **Other Facades.** Taller spaces are allowed on all other facades.
 - [3] **Measurement.** Taller spaces are calculated as multiple stories where each story is equal to the story height used on the majority of stories of the building or the average of the allowed floor-to-floor height of the building type.
 - [4] **Facade Treatment.** Taller spaces on any street facade must be articulated as multiple separate stories per the measurement required in this subparagraph (d), building type requirements for horizontal shadow lines and transparency, and building articulation standards per 660-59.C.
- (e) **Height Exceptions.** The height limitations of this ordinance do not apply to chimneys, ventilators, skylights, water tanks, and necessary mechanical appurtenances located on or extending above the roof. Such features shall not conflict with the special height limitations of Chapter 148 regarding Airport Approaches. Mechanical appurtenances on the roof are also regulated in 660-60. See the Tower regulations for accommodating other rooftop structures, such as elevator shafts and rooftop access.
- (f) **Commercial Communications.** The height of commercial communications towers and antennas are exempt from any building or roof type height regulations and are instead regulated in 660-34.B.

660-126.N TRANSPARENCY

Governed by the building type regulations, the transparency of a facade is measured for each story separately using 2 regulations: (1) an overall minimum transparency percentage per story, and (2) where applicable per building type, maximum blank wall segments (per 660-126.N.(3), below). See Article 3.

- (1) **Definition of Transparency.** For the purposes of this zoning ordinance, transparency is the measurement of the percentage of a facade that contains highly transparent, low-reflectance glass.
- (a) **Storefront.** When transparency is required separately for front street ground-story facades, glass must be a minimum of 60% transmittance

factor and a reflectance factor of not greater than 0.25.

- (b) **All Other Windows.** Transparency for all window, door glass, and other storefront glass must be a minimum of 50% transmittance factor and a reflectance factor of not greater than 0.25.
- (c) **False Windows.** The use of false or faux windows, where the window is visible from the exterior with no opening from the interior, to meet the transparency requirement is not allowed.
- (2) **Measurement.** Minimum facade transparency is measured from floor-to-floor of each story separately, except for required minimum ground-story transparency as defined below. See Article 3 for required transparency by building type.
- (a) Transparency requirements must be met with windows or glass in doors that comply with applicable transmittance and reflectance factors.
- (b) The measurement may include the frame, mullions, and muntins, but may not include trim or casing.
- (3) **Blank Wall Segments.** Where applicable per the building type regulations (see Article 3), blank wall segments on all facades must meet the following:
- (a) No rectangular areas greater than 30% of a story's facade, as measured floor to floor, may be blank wall, without transparency. See Figure 660(41).
- (b) No horizontal segments of a story's facade greater than 15 feet in width may be blank wall, without transparency. See Figure 660(42).
- (4) **Minimum Ground-Story Transparency.** When a separate minimum ground-story transparency is required per the building types requirements of Article 3, the ground-story transparency is measured between 2 feet and 10 feet from the average grade at the base of the facade.
- (5) **Taller Spaces.** Stories that are 18 feet or taller in height must include additional transparency on the facades consistent with the following standards. See Figure 660(43).
- (a) **Separate Ground Story Transparency Required.** When a separate minimum ground story transparency is required per building type (see Article 3), the facade design must fulfill that requirement in addition to the minimum transparency for the remainder of the facade.
- (b) **No Separate Ground Story Transparency Required.** Where no separate ground story

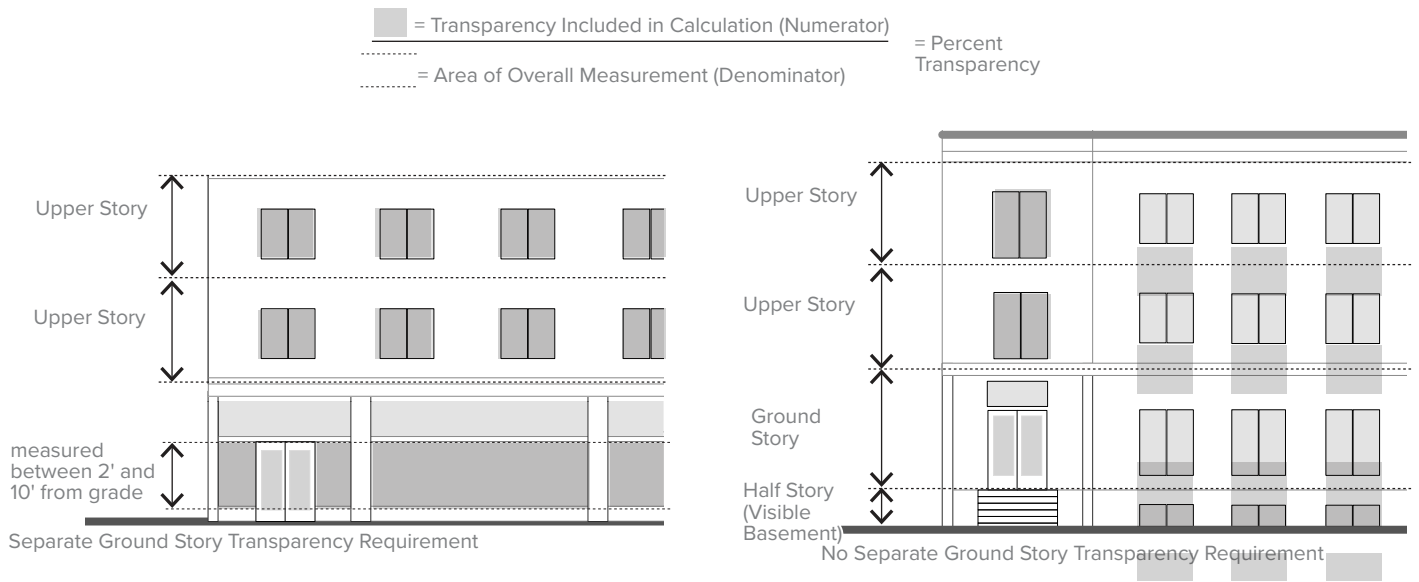

Figure 660(40) Measuring Transparency Floor-to-Floor

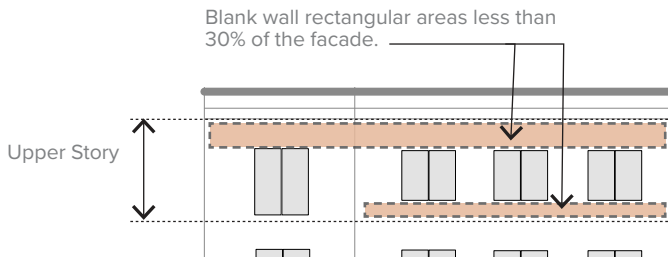

Figure 660(41) Blank Wall Segments (1)

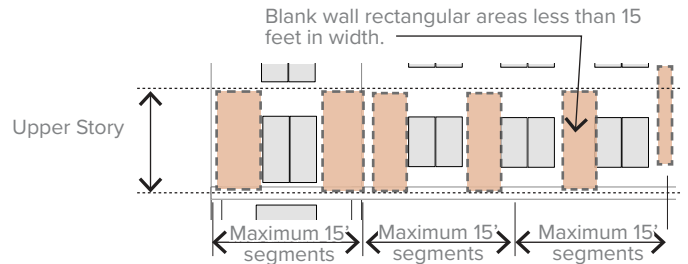

Figure 660(42) Blank Wall Segments (2)

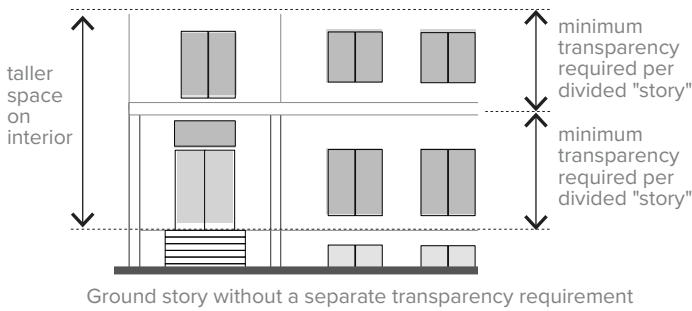

Figure 660(43) Measuring Transparency at Taller Spaces

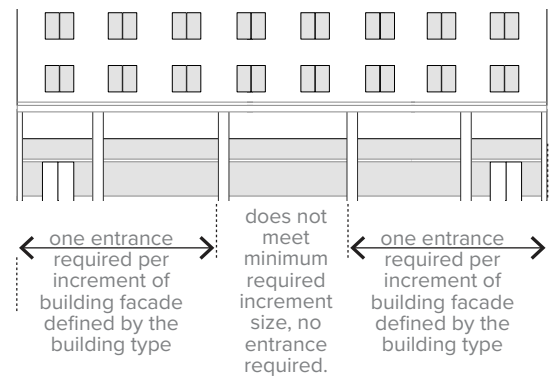

Figure 660(44) Entrances per Facade Increment

transparency is required per building type (see [Article 3](#)), the facade of taller spaces must be treated as multiple separate stories, divided between 9 and 14 feet apart, with the minimum transparency applied to each horizontal division.

- (6) **Half Stories.** All half story facades located within the roof structure and within visible basements must meet the minimum required transparency.

660-126.O BUILDING ENTRANCES

Entrances must be provided consistent with the entrance location and number of entrances, if regulated, established for the subject building type and consistent with [Figure 660\(44\)](#).

- (1) **Number of Entrances Required per Building Increments.** For longer buildings, the requirement is often stated as one entrance required per every X feet of front facade. The "every" means if increments of X feet are measured on the facade, and there is an increment left over that is less than X feet, that increment is not required to have an entrance. For example, if the requirement is one entrance per every 100 feet of facade, for a building that has a front facade 250 feet long, 2 entrances are required, but for a building 300 feet long, 3 entrances would be required.
- (2) **Location per Building Increments.** Once the number of entrances is determined, the location of those entrances must occur within the increments in order to space out the entrances along the facade.

660-127 Terms Beginning with "A"

ABUT. To have a common boundary or being along contiguous lot lines that are not separated by a street or alley.

ACCESSORY BUILDING, STRUCTURE OR USE. See [660-35](#).

ADAPTIVE REUSE. The conversion of 65% or more of the gross floor area of a principal building that was formerly occupied by nonresidential uses without any principal residential use into dwelling units. Projects that meet the definition of affordable housing or that involve conversion of a commercial storefront with a floor area of less than 5,000 square feet into dwelling units are not classified as adaptive reuse.

ADJACENT. To abut or be separated from another lot only by a street or improved alley.

AGENT. A person duly authorized to act on behalf of the owner of the subject property.

ALLEY. An improved public or private way having a right-of-way width of 24 feet or less. Where an "alley" is referred to within the ordinance, it means a constructed and improved alley and does not include vacated, unimproved, or planned alleys, except where a development agreement is in place for planned alleys to be constructed.

APPLICANT. The owner of the subject property or an agent authorized by the subject property owner to submit an application under this zoning ordinance on the property owner's behalf.

APPURTENANCES, ROOFTOP. Any fixed, non-structural appurtenance located on and above the roof, including such items as skylights, antennae, roof vents, chimneys, flue pipes, and other mechanical, electrical, or communications equipment, unless otherwise stated.

ARTERIAL STREET. A public street categorized by the comprehensive plan or adopted transportation plan as an "arterial street."

AWNING. A roof-like structure typically made of cloth, metal or other material attached to a frame that extends from and is supported by a building. Awnings are typically erected over a window, doorway or building front and they may be raised or retracted to a position adjacent to the building.

660-128 Terms Beginning with "B"

BASEMENT. That portion of a building having 3 feet or more of its floor-to-ceiling height below the average finished grade of the abutting ground and with a floor-to-ceiling height of 7.5 feet or more. See [Figure 660\(39\)](#).

BASEMENT, VISIBLE. A basement having more than 3 feet of its floor-to-ceiling height above the average finished grade of the adjoining ground. See [Figure 660\(39\)](#).

BLOCK FACE. That portion of a block adjacent and parallel to the abutting public street and normally extending from one intersecting street to another. A corner lot is considered part of the block face parallel to the lot's front lot line.

BRING YOUR OWN BOTTLE (BYOB) ESTABLISHMENT. An eating or drinking place or community assembly use that is not licensed by the Pennsylvania Liquor Control Board, in which no intoxicating beverages are sold, but where patrons are permitted to bring intoxicating beverages upon the premises solely for their own use and consumption.

BUILDING. Any permanent, roofed structure with or without enclosed sides and any unroofed platform, terrace, or porch having a vertical face higher than 30 inches above the level of the ground from which the height of the building is measured. All buildings are structures, but only those structures that meet this definition are considered buildings.

BUILDING, PRINCIPAL. A building in which the principal use of the subject lot is conducted.

BUILDING, SINGLE-PURPOSE RESIDENTIAL. A building in occupied exclusively by residential uses, with no other principal use.

BUILD-TO ZONE. An area in which the street facade of a principal building must be placed, dictated by the minimum and the maximum distance the building must be placed from the front street or side street lot line. See [660-126.G](#).

BUS. A motor vehicle other than a taxicab or limousine, designed to transport 16 or more passengers, including the driver.

660-129 Terms Beginning with "C"

CALIPER. The diameter of a tree trunk measured per [660-65.C](#) for new trees being installed or [660-67](#) for existing trees.

CELLAR. See definition of "basement" in [660-128](#).

CERTIFICATE OF OCCUPANCY. A certificate issued by code enforcement officials of the city upon completion of

construction or alteration of a building or upon approval of a change in occupancy or use of a building.

CITY. The City of Allentown.

CITY COUNCIL. The city council of the City of Allentown.

COMMERCIAL VEHICLE. A motor vehicle that is a Class 5 vehicle or above and is primarily used for business purposes, including making service calls, transporting equipment used in a business, or in accomplishing physical work as part of a business (such as hauling material). Does not include tractor trailers (see [660-146](#)).

COMPREHENSIVE PLAN. The most recent version of the city's official comprehensive plan, as adopted by city council.

CORNICE. A horizontal decorative moulding projecting from the top of a wall and, in the case of a flat roof type, located where the roof meets the wall.

CORRIDORS, MIXED-USE. See "mixed-use corridors."

COURTYARD. A courtyard is any open air, uncovered landscape, sidewalk, patio, terrace, or deck area, enclosed on at least 2 sides by a building or multiple buildings. Sides may be enclosed by buildings on abutting lots.

660-130 Terms Beginning with "D"

DECISION-MAKING BODY (OR AUTHORITY). The individual or entity with authority and responsibility for making a final decision under the procedures of this ordinance.

DEMOLITION. The dismantling, tearing down, removal or razing of the exterior of a building, in whole or in part. Changes to the interior of a building do not constitute demolition, provided such changes do not impair the structural stability of the building.

DEMOLITION, PARTIAL. The removal of one or more rooms of a building, removal of an attached porch (other than a ground level patio), turrets, dormers, and other similar structural elements, that are visible from a public street. Partial demolition is regulated in the same manner as demolition.

DORMER. A roofed structure containing a window that is set on and projects vertically from a pitched roof, typically used to create space and light within an area directly below a pitched roof.

DRIVE-THROUGH FACILITY. A structure or part of a structure that provides for some or all customers to receive

services, obtain food or other goods, or be entertained while remaining in their motor vehicles.

DWELLING UNIT. One or more habitable rooms comprising complete independent living facilities for one or more persons, and including within those rooms permanent provisions for living, sleeping, eating, cooking, and sanitation. A dwelling unit is intended for occupancy by a single household. A separate dwelling unit is deemed to exist when all 3 of the following characteristics exist, regardless of the representations of the property owner:

- (1) The habitable room(s) have independent access to the exterior (either directly, or through a common foyer or lobby);
- (2) The presence of a sanitation facilities in the form of a bathroom, including a sink and bathtub and/or shower (or plumbing rough-ins for a bathtub or shower); and
- (3) The presence of eating and cooking facilities in the form of a stove and sink (separate from the bathroom or laundry room sinks), or rough-ins for stoves and sinks (such as a gas line, or line for a stove or plumbing connection for separate sink).

DWELLING UNIT, ACCESSORY (ADU). A separate dwelling unit within a building occupied by a principal dwelling unit or a separate dwelling unit within an accessory outbuilding located on a lot occupied by a principal dwelling unit. Accessory dwelling units are subject to the regulations of [660-36](#).

660-131 Terms Beginning with "E"

EAVE(S). The edge of the roof that overhangs the face of a wall and typically projects beyond the side of a building.

ELECTRIC VEHICLE. Any vehicle that is licensed and registered for operation on public and private highways, roads, and streets. Electric vehicles are powered partially or exclusively on electrical energy from the grid or an off-board source, that is stored on-board via a battery. Electric vehicles include: (1) battery electric vehicles; and (2) plug-in hybrid electric vehicles.

ELECTRIC VEHICLE CHARGING LEVELS. The standardized indicators of electrical force, or voltage, at which an electric vehicle's battery is recharged. The terms 1, 2, and DC are the most common charging levels, and include the following specifications:

- Level 1 is considered slow charging with 120v outlets.
- Level 2 is considered medium charging with 240v outlets, charging head and cord hard-wired to the circuit.

- Level 3/DC is considered fast or rapid charging. Voltage is greater than 240.

ELECTRIC VEHICLE (EV) CHARGING STATION. A public or private parking space that is served by battery charging station equipment.

ELECTRIC VEHICLE CHARGING STATION, PRIVATE (RESTRICTED-ACCESS). An EV charging station that is not available for use by the general public. Examples include electric vehicle charging stations that serve residential homeowners or renters, executive parking areas, designated employee parking areas, and fleet parking areas.

ELECTRIC VEHICLE CHARGING STATION, PUBLIC. An EV charging station that is accessible to and available for use by the general public.

ELECTRIC VEHICLE PARKING SPACE. Any parking space that is clearly identified to be used exclusively for the parking of an electric vehicle.

ELECTRIC VEHICLE SUPPLY EQUIPMENT (EVSE). The conductors, including the ungrounded, grounded, and equipment grounding conductors, and the electric vehicle connectors, attachment plugs, and all other fittings, devices, power outlets, or apparatus installed specifically for the purpose of transferring energy between the premises wiring and an electric vehicle.

EMPLOYEES. Full-time and part-time workers present on a lot at one time, other than clearly temporary persons working on physical improvements to the site. Volunteers and contractors are considered employees.

660-132 Terms Beginning with "F"

FACADE, SIDE-STREET. A building facade generally parallel to and facing the right-of-way line along a non-front or side street.

FACADE, FRONT. A building facade generally parallel and facing the right-of-way line along a front street or other specifically designated frontages.

FACADE, REAR. Any facade of a building generally parallel to and facing the rear lot line.

FACADE, SIDE. Any facade of a building generally parallel to and facing a side or interior side lot line.

FACADE SEGMENT. A rectangular portion of a facade measured linearly along the bottom of a story for the width then to the top of the story's height vertically. Story height is measured top of floor to top of the next floor per [660-126.M](#).

FACADE, STREET. Any facade of a building generally parallel to and facing any street right-of-way and including bays or minor walls perpendicular to the facade. The facade may be a front or side street facade, depending on whether it is facing a front or side street, respectively.

FACE OF CURB. The vertical or sloping surface on the roadway side of a street curb.

FAMILY. See definition of "household" in 660-134.

FENCE. A constructed barrier of wood, masonry, stone, wire, metal or other manufactured material or combination of materials erected for the enclosure of areas.

FLOOR AREA RATIO (FAR). See 660-126.M(5).

FLOOD PLAIN. The relatively flat or low land area that is subject to partial or complete inundation from an adjoining or nearby stream, river or watercourse; and/or any area subject to the unusual and rapid accumulation of surface waters from any source. See the definitions of terms in Chapter 298 entitled "Flood Control."

FLOOR AREA. The total horizontal areas of the floors of a building, measured inside exterior building walls or party walls separating buildings. Floor area does not include vehicle garages, loading space for motor vehicles, uninhabited basement storage areas, unenclosed porches, air shafts, common mechanical equipment rooms, cellars or any space where the ceiling height is less than 6.5 feet.

FLOOR AREA, HABITABLE. The floor area of a dwelling unit or other rental unit that is enclosed, heated and usable for human occupancy. Common stairwells, common hallways and elevator shafts are not counted as habitable floor area.

FRONTAGE, SIDE-STREET. The portion of a lot or building abutting or directly adjacent to a side street right-of-way.

FRONTAGE, FRONT. The portion of a lot or building abutting or directly adjacent to a front street right-of-way or other frontage defined as a "front."

FRONTAGE, STREET. The portion of a lot or building abutting or directly adjacent to a street right-of-way.

660-133 Terms Beginning with "G"

GOVERNMENTAL. Owned or operated by city, county, state or federal governmental agencies or a city authority.

GRADE, FINISHED. The elevations of the ground surface of a site after completion of all site preparation work for new construction or the existing, undisturbed grade for existing buildings.

GRADE, AVERAGE FINISHED. The average of the elevations of the ground surface of a site after completion of all site preparation work for new construction or the existing grade for existing buildings. Where the adjoining or abutting grade is referenced, the measurement is taken along the line between the structure and the grade.

GRADE, NATURAL OR EXISTING. The elevations of the ground surface of a site in its natural state, before human-made alterations, excavations, or filling, and measured as the degree of rise or descent of a sloping surface.

GREEN ROOF. The roof of a building that is partially or completely covered with vegetation and a growing medium, planted over a waterproofing membrane. It may also include additional layers such as a root barrier and drainage and irrigation systems.

GREEN WALL. A wall partially or completely covered with vegetation that includes a growing medium, such as soil or a substrate. Most green walls also feature an integrated water delivery system. Green walls are also known as living walls or vertical gardens.

GROUND LEVEL. The mean elevation over the entire length of the street lot line of a lot.

660-134 Terms Beginning with "H"

HARDSCAPE. Non-living materials, and their use and design, that constitute one component of landscaping. Hardscape includes paving, walls or fences, concrete, asphalt, stone, or other hard surface that may be used to construct retaining walls, paths, walkways, decks, terraces, accent features, and enclosures.

HIGH-CAPACITY TRANSIT ROUTE. A street segment with LANTA bus service frequencies of 15 minutes or lower. Such routes are identified on a GIS layer maintained by the city.

HOME OCCUPATION. An accessory use of a dwelling unit for business, commercial, or work-related purposes. Home occupations are subject to the regulations of 660-42.

HOUSEHOLD. Any one of the following:

- (a) A single person occupying a dwelling unit;
- (b) Any number of persons related to each other by blood, marriage, civil union, committed partnership, adoption, or documented responsibility (such as foster care or guardianship), all of whom occupy a dwelling unit as a single housekeeping unit; or
- (c) Up to 4 adults of any relationship, plus any minor children related to one or more of the adults by blood, adoption or documented responsibility,

all of whom occupy a dwelling unit as a single housekeeping unit without any additional boarders.

HOUSEKEEPING UNIT. A household comprised of persons who live together as a traditional family or as the functional equivalent of a family, and who share household activities and responsibilities, such as meals, chores, rent, and expenses. The choice of specific adults comprising the single nonprofit housekeeping unit is determined by the members of such housekeeping unit rather than by a landlord, property manager, or other third party. Members of a single housekeeping unit are not required to seek services or care of any type as a condition of residency. All members of the housekeeping unit jointly occupy the entire dwelling unit.

660-135 Terms Beginning with "I"

INTOXICATING BEVERAGE. Any and all beverages, including malt beverages that contain alcohol, liquor or such other intoxicating substances as are further defined in the Pennsylvania Liquor Code 47 P.S. 1-101, et seq.

660-136 Terms Beginning with "J"

JUNK. Material that is obsolete, worn out, broken, or otherwise of little to no value and that is typically discarded.

660-137 Terms Beginning with "K"

RESERVED

660-138 Terms Beginning with "L"

LANDSCAPE (OR LANDSCAPED) AREA. The area on a site that is landscaped with the installation and maintenance typically of a combination of trees, shrubs, and groundcover plants to improve the site's aesthetic quality. Does not include bare soil, uncultivated vegetation, impervious surfaces, and gravel.

LAWFULLY ESTABLISHED. A use, structure, lot or sign (as the context indicates) that was established in conformance with all applicable zoning ordinance regulations in effect at the time of its establishment.

LIGHT TRESPASS. Light that is emitted into an unintended area.

LIVE-WORK UNIT OR LIVE-WORK SPACE. A dwelling unit or other space within a building that is used jointly for residential and nonresidential purposes that typically exceed those of a home occupation use pursuant to the regulations of this zoning ordinance.

LOT. A designated parcel, tract or area of land established by plot, subdivision, or as otherwise permitted by law, to be used, developed, or built upon as a unit.

LOT AREA. See 660-126.D.

LOT, CORNER. A parcel of land at the junction of and fronting on 2 or more intersecting streets.

LOT FRONTAGE. A property line that is co-existent with a street right-of-way line. In the case of a street of undefined width, the property line is assumed to parallel the centerline of the street at a distance 25 feet from the street's centerline.

LOT LINE. A line forming the front, rear or side boundaries of a lot or parcel of property as described in the recorded deed.

LOT, THROUGH OR DOUBLE FRONTAGE. A lot having its front and rear yards each abutting on a street as defined herein.

LOT WIDTH. See 660-126.C.

660-139 Terms Beginning with "M"

MANUFACTURING. The treatment or processing of raw products, and the production of articles or finished products from raw or prepared materials by giving them new forms or qualities.

MIXED-USE CORRIDORS. Mixed-Use Corridors is a set of street corridors specifically designated due to their proximity to transit, a mix of uses, and the carrying capacity of the corridor. Mixed-Use Corridors are located on a GIS layer maintained by the City and available on the zoning map.

MULTI-TENANT DEVELOPMENT. A development typically under unified ownership and control consisting of two or more business establishments, which may be on the same lot or on separate lots. The tenants of a multi-tenant development typically share vehicle access and parking facilities.

MUNICIPALITIES PLANNING CODE. The Pennsylvania Municipalities Planning Code, as amended.

660-140 Terms Beginning with "N"

NONCONFORMITY. A nonconforming lot, nonconforming use, nonconforming structure, nonconforming development feature, or nonconforming sign, as those terms are defined in Article 12.

660-141 Terms Beginning with "O"

OCCUPIED BUILDING SPACE. Interior building space occupiable by people on a regular basis, not including storage, mechanical, utility, or garage space.

OPEN LANDS. Land that is permanently restricted to primarily be used for natural feature conservation or active or passive recreation. Such land shall be permanently restricted by a conservation easement or deed restriction to prevent further subdivision and to prevent development of uses or buildings, except for types of non-commercial recreation uses, stormwater management uses and utility purposes that are specifically authorized by the City of Allentown. This land shall include a suitable method for ownership and maintenance of the land that is approved by the City of Allentown. Such land shall be open for responsible recreational use by occupants of the development, and portions of the land may be opened to responsible use by the general public.

ORDINARY HIGH WATER MARK. The line on a shoreline established by the fluctuations of water and indicated by physical characteristics such as clear, natural line impressed on the bank, shelving, changes in the character of soil, destruction of terrestrial vegetation, the presence of litter and debris, or other appropriate means that consider the characteristics of the surrounding areas. Per 33 CFR § 328.3(e) federal regulations.

OUTDOOR DISPLAY. The outdoor exhibition of products, vehicles, equipment and machinery for sale or lease during business hours only. Outdoor display does not include goods that are being stored or parked outdoors, outside of business hours (see also "outdoor storage").

OUTDOOR STORAGE. The storage of goods, products, materials, vehicles not in service, equipment and similar items in an unenclosed area for preservation, later use, or disposal. For purposes of this zoning ordinance, this definition does not include the storage of trucks and/or tractor trailers unless as accessory to another permitted principal use.

660-142 Terms Beginning with "P"

PARKING LOT (OR AREA). An off-street area containing accessory or non-accessory motor vehicle parking spaces and associated motor vehicle maneuvering and circulation areas.

PARKING SPACE. A designated indoor or outdoor space meeting city requirements that is intended to accommodate a single parked motor vehicle. Also known as a "parking stall."

PARTY WALL. A vertical wall built between and to support contiguous buildings.

PAVEMENT. Asphalt, brick, block, concrete, pervious concrete, pervious asphalt, or porous permeable pavers.

PIGEON COOP. A cage or small enclosure for the purpose of housing pigeons.

PLAN, CERTIFIED. A plan prepared by a state-licensed and registered professional engineer, architect, landscape architect or surveyor. All certifications must meet applicable state laws.

PLANNING COMMISSION. The Allentown City Planning Commission (ACPC).

PORCH. A platform covered by a roof at the entrance to a house or rowhouse building.

PORCH, ENCLOSED. Any porch other than an open porch.

PORCH, OPEN. A porch that is open on 3 sides and that has no enclosed features of glass, wood or other material more than 30 inches above the floor of the porch, except for transparent mesh screening and necessary roof supports. A porch is not considered open if enclosed by either permanent or detachable glass sash.

PRELIMINARY OPINION. A written review and opinion given by a zoning officer as provided in 660-109.E.

PRINCIPAL STRUCTURE. A structure or combination of structures of chief importance or function on a site. In general, the primary use of the site is carried out in a principal structure. The

PRINCIPAL USE. An activity or combination of activities of chief importance on the site. One of the main purposes for which the land or structures are intended, designed, or ordinarily used.

PROPERTY LINE. Same as "lot line."

660-143 Terms Beginning with "Q"

RESERVED

660-144 Terms Beginning with "R"

RECREATIONAL VEHICLE (RV). A trailer, boat trailer, travel trailer, camping trailer, truck camper, camper shell, motor home, tent trailer, boat, houseboat, or similar vehicle or unit. Camper shells that are attached to a pickup truck are not considered a recreational vehicle.

RESIDENTIAL (DWELLING) UNIT. That portion of a building providing living space for an individual household.

660-145 Terms Beginning with "S"

SALE. Purchase or rental of goods, or provision of services, in return for monetary compensation.

SETBACK. An open, unobstructed area that is required to be provided by this zoning ordinance between a building and a lot line.

SHADOW LINE. An architectural feature consisting of a typically decorative, 3-dimensional, linear element, horizontal or vertical, protruding or indented at least 1.5 inches in depth from the exterior facade of a building, and creating a shadow on the facade with light overhead, and extending, with limited interruption, the length or height of the designated story. Examples may include cast stone cornices or lintels, pilasters, or stepped brick coursing.

SIGN. See [660-89.F](#) for sign-related definitions.

SITE AREA. The gross area of the lot, portions of a lot, or series of lots referenced.

SOLAR ENERGY SYSTEM. A system intended to convert solar energy into thermal, mechanical, or electrical energy.

SOLAR ENERGY SYSTEM, BUILDING-INTEGRATED. A solar energy system that is an integral part of a principal or accessory building, rather than a separate mechanical device, replacing or substituting for an architectural or structural part of the building. Building-integrated systems include, but are not limited to, photovoltaic or hot water systems that are contained within roofing materials, windows, skylights, shading devices, and similar architectural components.

SOLAR ENERGY SYSTEM, STRUCTURE-MOUNTED. A solar energy system that is mounted on the façade or roof of either a principal or accessory structure.

SOLAR ENERGY SYSTEM, FLUSH-MOUNTED. A solar energy system that is mounted flush with a finished building surface, at no more than 6 inches in height above that surface.

SOLAR ENERGY SYSTEM, GROUND-MOUNTED. A solar energy system mounted on the ground and not attached to any other structure other than structural supports.

SOLAR PANEL. A group of photovoltaic cells assembled on a panel. Panels are assembled on-site into solar arrays.

SPECIFIED ANATOMICAL AREAS. Less than completely and opaquely covered human genitals, pubic region, buttock or female breast below a point immediately above the top of the areola.

SPECIFIED SEXUAL ACTIVITIES. (1) Human genitals in a state of sexual stimulation or arousal; (2) acts of human masturbation, sexual intercourse or sodomy; or (3) fondling or other erotic touching of human genitals, pubic region or female breast.

STATE. The Commonwealth of Pennsylvania, and its governmental agencies.

STOREFRONT PLATFORM. A secondary walkway elevated on a platform above and generally parallel to the public sidewalk. The platform extends parallel to the building facade providing access into the building and viewing into storefront windows.

STORY. That part of a structure included between any floor and the floor or roof next above. Basements are not a story unless the basement qualifies as a visible basement. Visible basements are half stories, unless otherwise specified. See building height measurement in [660-126.M](#).

STORY, GROUND. The story closest to the ground level that does not meet the definition of a basement. Also called ground floor.

STORY, HALF. See building height measurement in [660-126.M](#).

STREET. A thoroughfare publicly or privately owned, open to general public use.

STREET, FRONT. A street that is generally parallel to the front lot line. Front streets are determined by the A, B, or C street designations per [660-12.J](#).

STREET, SIDE. A street that abuts a lot and is not a front street. Front streets are determined by the A, B, or C street designations per [660-12.J](#).

STREETSCAPE. The overall appearance of a block along a public street, including yards visible from a public street, the relationship of building setbacks and bulk, the consistency of architectural styles or features, the spacing and shapes of windows and doors and rooflines and similar features that give the block its distinctive visual character. See also the regulations of [350-12](#) in land use and subdivision regulations.

STREETSCAPE AREA. The area behind the face of curb designed for pedestrian travel, including the sidewalk and buffer zone between the sidewalk and street for street planting and/or street furnishings.

STREETWALL. The portion of the building facade that is located generally parallel and facing the street right-of-way line.

STREET LINE. The right-of-way or established property line of a street as indicated by dedication or by deed of record.

STRUCTURE. Anything constructed or erected, which requires its permanent location on or below the ground, or that is permanently attached to something having permanent location upon the ground. Fixed or movable awnings are not by themselves considered a structure for the purposes of this zoning ordinance.

660-146 Terms Beginning with "T"

TRACT. A single lot or contiguous lots in common ownership or common equitable ownership at the time of submittal for subdivision, land development or planned residential development approval. Such lots may be separated by a creek, railroad or street.

TOTAL AREA OF THE TRACT. The total lot area of a single lot or contiguous lots in common ownership or common equitable ownership at the time of submittal for subdivision, land development or planned residential development approval. The total area of the tract shall not include areas within the existing rights-of-way of existing streets, but may include portions of the lot proposed for new streets or proposed for new common open space.

TRACTOR. A motor vehicle designed and used primarily for drawing other vehicles and not constructed so as to carry a load other than a part of the weight of the vehicles and load so drawn.

TRACTOR TRAILER. Every vehicle, wagon or truck without motive power designed to carry property or passengers wholly on its own structure and to be drawn by a tractor as defined by this zoning ordinance.

TRUCKING TERMINAL. An area or building where trucks load and unload materials on a regular basis, or where tractor trailers are transferred from one tractor cab to another for the purpose of continuation to another destination, or where trucks or tractors or tractor trailers are stored, parked or waiting for dispatch.

660-147 Terms Beginning with "U"

USE. The specific purpose or activity for which a structure, building, or land is or may be designed, arranged, designated, or intended or for which a structure, building, or land is or may be occupied and maintained.

USE CATEGORY. A class of similar uses grouped together for purposes of delineating the uses permitted in a zone. See also [Article 4](#).

660-148 Terms Beginning with "V"

VEHICLE FUELS, ALTERNATIVE. Electricity, CNG (compressed natural gas), LNG (liquefied natural gas), LPG (liquefied petroleum gas), and hydrogen.

VEHICLE FUELS, CONVENTIONAL. Gasoline and diesel fuels.

660-149 Terms Beginning with "W"

WATERFRONT. Water frontage along a waterway.

WATERWAY, MAJOR. Major waterways include the Lehigh River, Lehigh Coal and Navigation Canal (D+L), Jordan Creek, Cedar Creek, Trout Creek, Little Lehigh Creek, Little Cedar Creek, Lake Muhlenberg, and Joseph S. Daddona Lake.

WATERWAY, MINOR. Waterways, whether navigable or not, including creeks, brooks, ponds, lagoons, rivers, lakes, and other unnamed, minor waterways, not including those waterways designated as major waterways.

WHOLESALE SALES. An establishment or place of business primarily engaged in selling merchandise to retailers and industrial, commercial, institutional or professional business users, or to other wholesalers or acting as agents or brokers and buying merchandise for, or selling merchandise to, such individuals or companies.

WIND ENERGY CONVERSION SYSTEM. A device that directly converts wind energy into usable thermal, mechanical, or electrical energy, including such devices as windmills and wind turbines. The "system" includes towers and supporting structures and directly connected facilities such as generators, alternators, inverters, batteries, and associated control equipment.

WIND ENERGY CONVERSION SYSTEM, SMALL. A wind energy conversion system with a power-rated capacity of no more than 100 kW that is primarily intended to produce power for on-site consumption, as a supplement to utility power or in lieu of utility power.

660-150 Terms Beginning with "X"

RESERVED

660-151 Terms Beginning with "Y"
.....

YARD. An actual (as opposed to “required”) open, unoccupied space that exists on a lot between a building and a lot line.

YARD, FRONT. A street yard extending along the full width of the lot and lying between the principal building and a front street right-of-way.

YARD, INTERIOR. On lots with multiple buildings, a yard between any buildings that does not abut any lot line.

YARD, REAR. A yard extending between the side-street yard and the interior side lot line and lying between the rear of the principal building and the rear lot line.

YARD, SIDE. A yard extending from the front yard to the rear yard and lying between the side of the principal building and the side lot line.

YARD, SIDE-STREET. A street yard extending between the principal building and a side street right-of-way and lying between the front yard and the rear lot line.

YARD, STREET. Any yard between the principal building and a street right-of-way.

YARD SALE. All general sales, open to the public, conducted from a residential property in any zoning district, for the purpose of disposing of household items including, but not limited to, all sales entitled “garage”, “lawn”, “yard”, “attic”, “porch”, “room”, “basement”, “auction”, “backyard”, “patio”, “flea market”, “rummage” or “moving” sale.

660-152 Terms Beginning with "Z"
.....

ZONING HEARING BOARD. The Zoning Hearing Board of the City of Allentown.

ZONING OFFICER. The zoning supervisor and any assistants authorized to administer and enforce this zoning ordinance.

ZONING PERMIT. A permit stating that the purpose for which a building or land is to be used is in conformity with all applicable provisions of this zoning ordinance.